

TEM



touching completeness

TEM



Vitajte v rodine \square O D U L

Welcome to the \square O D U L family

Pre vás dopĺňame a zlepšujeme modernú rodinu
spínačov pre všetky druhy vašich miestností.

We are expanding and perfecting the modern
Modul switch family for all types of rooms.

touching completeness

MODUL

Dizajnové línie Pure, Line a Soft sú odrazom moderného, sofistikovaného a nezávislého životného štýlu. Môžete si vybrať zo širokej a bohatej škály farieb, vzorov a tvarov a jednoducho tak prispôsobiť svoje spínače a zásuvky požadovanému priestoru a nálade.

The Pure, Line and Soft design lines reflect a modern, sophisticated and independent lifestyle. You can choose from a wide and rich selection of colours, patterns and shapes to alter the appearance of your switches and sockets so that they fit the desired atmosphere and mood.

PURE

prírodné materiály
natural materials

drevo wood
kov metal
sklo glass

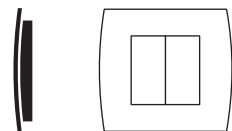

line

soft

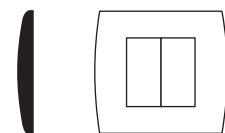
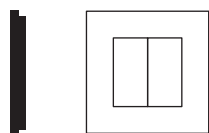

PURE



nádherné bývanie wonderful living

Z čistoty a nepoškvrnenosti novorodeného sveta sa zrodil príbeh Pure. Dotyk prírodných motívov sa prelína s dômyselným vkusom pre línie a tvar a je pretkaný niťami špičkovej technológie.

From the cleanliness and purity of a new-born world stems the story of the Pure line. The touch of natural motifs is intertwined with a sophisticated taste for lines and form and interwoven with threads of state-of-the-art technology.



PURE

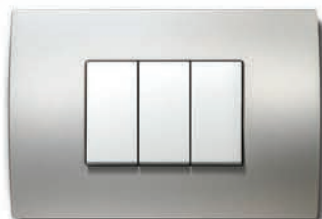
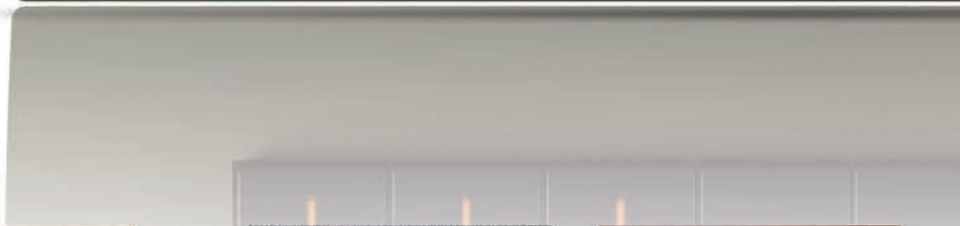
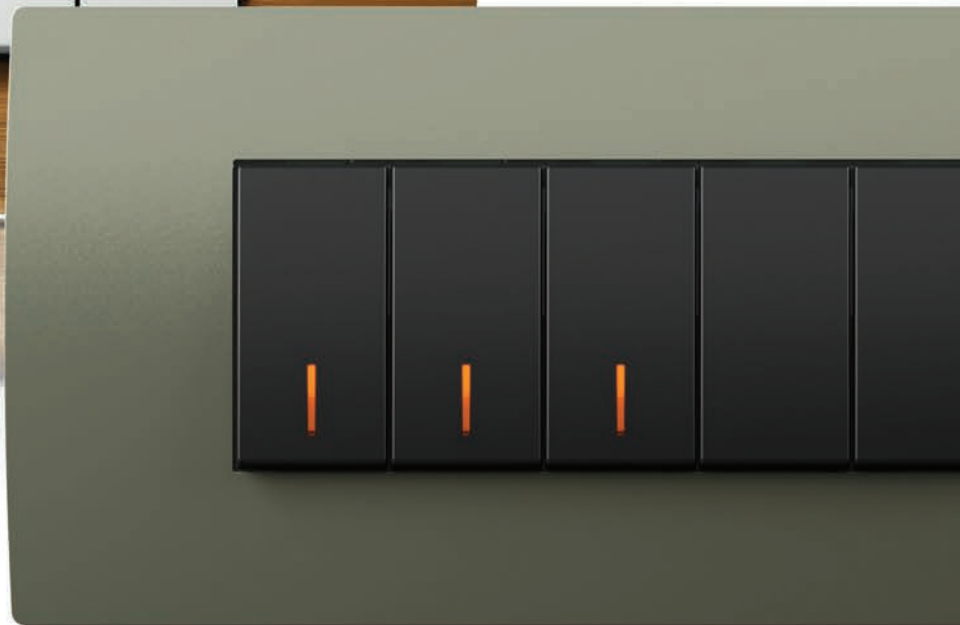



pocit prírody feeling of nature

Línia spínačov Pure sa vyznačuje prírodnými materiálmi: kov, drevo, sklo. Špecifický pocit je vyjadrený jedinečným dizajnom, ktorý je zarážajúci, zároveň však nevtieravý. Vyžaruje citlivosť, sofistikovanosť, kritériá vysokého štandardu a samozrejme čistotu.

The Pure switch line is distinguished by its natural materials: metal, wood and glass. Its unique design gives it a special touch. It is striking yet unobtrusive. It radiates sensuality, sophistication, high standards and, of course, cleanliness.

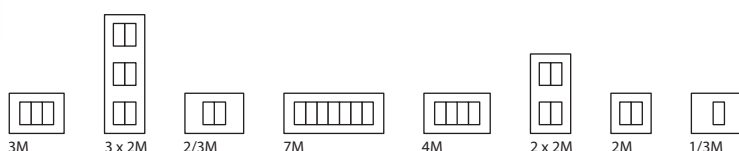

line



harmónia rovných tvarov harmony of straight lines

Pripravte sa na elegantnú dokonalosť rovných tvarov. Vyskúšajte lesklosť povrchov, ktoré sa nežne pohrávajú s modernými prvkami vo vašich priestoroch. Špeciálne pre vás sme vyvinuli technológiu "Soft Touch", aby bol pre vás každý dotyk osobitným zážitkom.

Get ready to witness the elegant perfection of straight lines. Experience the brilliance of surfaces that are completely harmonious with the modern elements of your room. The switches feature "Soft Touch" technology developed especially for you to make every touch a wonderful experience.



line

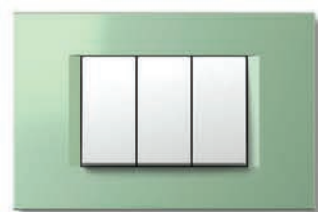
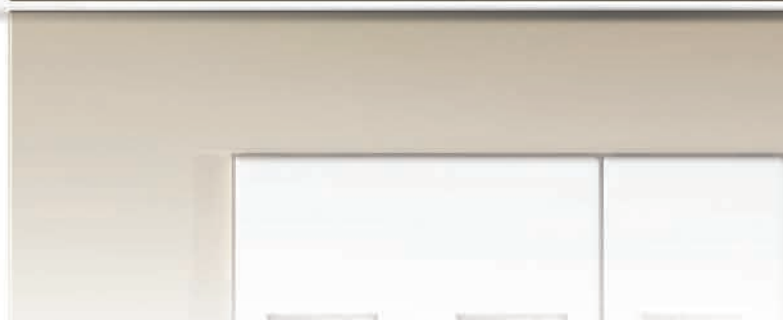
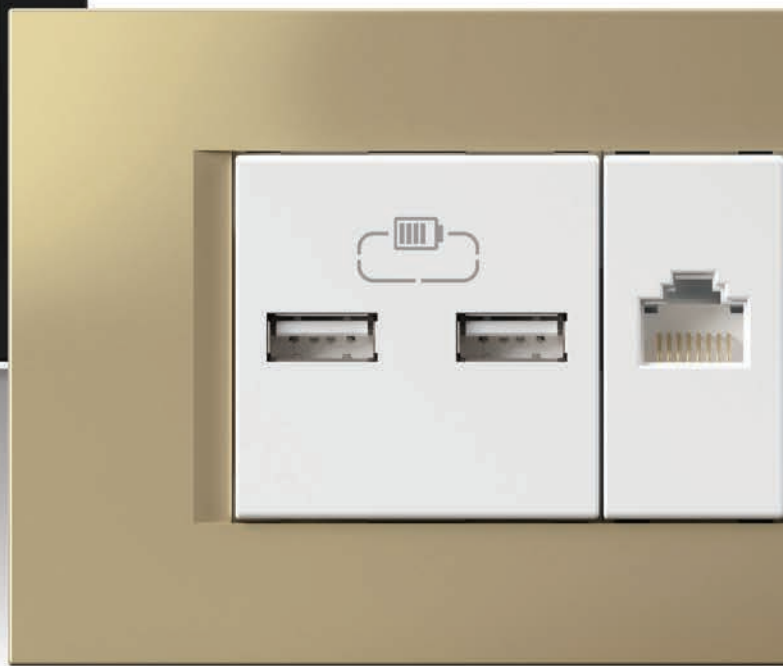



moderný dizajn modern design

Čisté, rovné línie vytvárajú nadčasový dizajn.
Dokonalý, rovný, tenký profil a ergonomia mäkkého dotyku dodávajú elegantný vzhľad zo všetkých uhlov.

Its straight, smooth lines make for a timeless design.
Its perfectly straight, sleek profile and soft-touch ergonomics give it an amazingly elegant appearance from all angles.

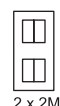
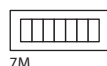
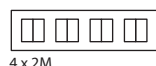

soft



mäkkosť vo vašom domove

softness in your home

Dovoľte, aby zaoblené tvary a jemné prechody
priniesli mäkkosť do vášho domova.

Let the rounded shapes and soft transitions
bring softness into your home.



soft



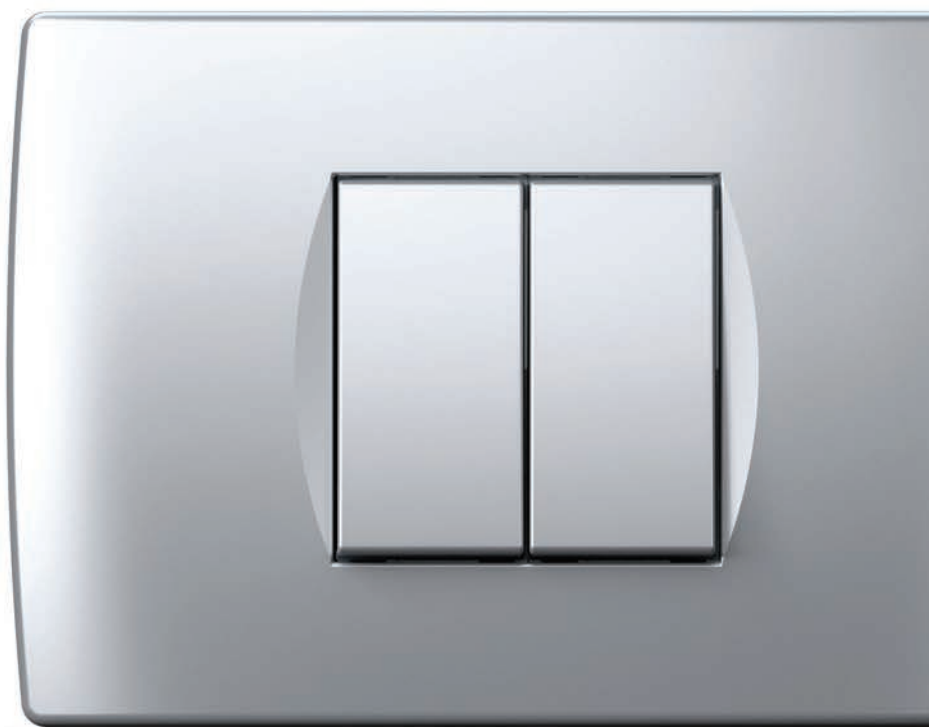

teplo domova a warm home

Dokonale jemné tvary doplnené subtílnym výberom farieb a špeciálnymi nátermi, ktoré pri dotyku pocítite.

Perfectly soft shapes rounded off by a subtle selection of colours and special coatings for a special touch.

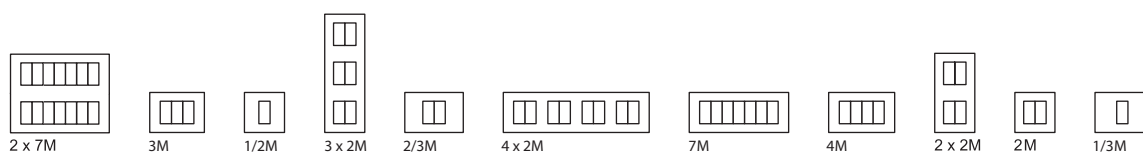

univerzálny stmievač

universal dimmer

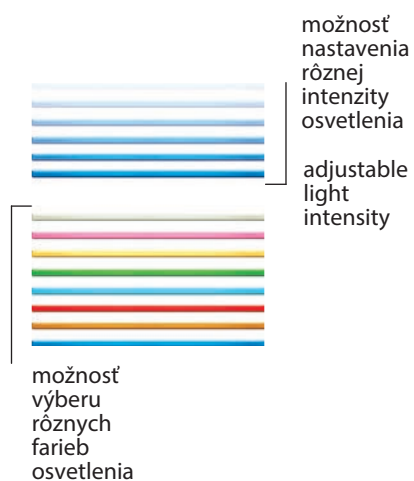
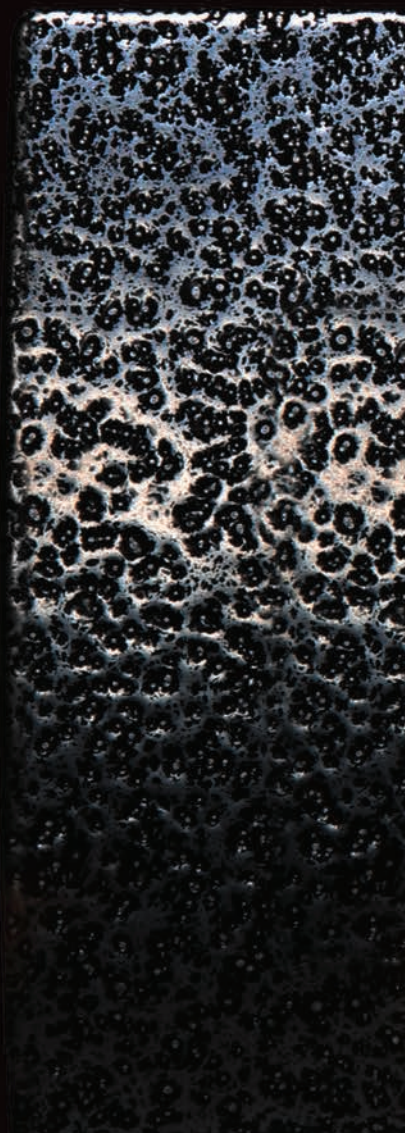

možnosť
nastavenia
rôznej
intenzity
osvetlenia

adjustable
light
intensity

možnosť
výberu
rôznych
farieb
osvetlenia

choosing
illumination
colour

V tme sa Touch zmení na jemné, ambientné svetlo, ktoré označuje miesto spínača. Môžete si vybrať medzi ôsmimi rôznymi farbami jemného svetla a upraviť jeho jas podľa svojej nálady.

In the dark Touch becomes a tender soft ambient light. It marks the spot of a switch and gently illuminates a place. You can choose among eight different colours of tender light and adapt its brightness according to your mood.



svetlo ako nikdy predtým light as never seen before

Timené svetlo vytvára pokojnú atmosféru, plnú zmyselnosti a romantiky. Je ochranným znakom romantických kútikov a pokojných chvíľ v neskorých večerných hodinách strávených doma alebo v práci. Mäkké a postupné zapínanie predlžuje životnosť žiarivky, je zároveň oveľa príjemnejšie a pomalšie nahradí tmu svetlom. Touch umožňuje stlmiť svetlo bez ohľadu na typ žiarivky alebo žiarovky.

A dimmed light makes peaceful, sensual and romantic atmosphere. It is a trade mark of romantic places and quiet late evening hours spent at home or at work. Switching is soft and extended. It does not only prolong the lamp life expectancy, but also changes darkness into light in a slower and much more pleasant way. Touch enables you to dim the light anywhere, regardless of the type of lamps.





všetko na jednom mieste

everything in one place

Váš dom je centrom vášho života. Množstvo zariadení vyžaduje rad konektorov a zásuviek. Vytvorte si svoje vlastné multimediálne centrum, ktoré vám umožní pripojiť a ovládať rôzne komponenty na jednom mieste.

Your house is the centre of your life. The multitude of devices you use requires a number of connectors and sockets. Create your own multimedia centre, one that will allow you to connect and use a multiple number of different components in one place.



inovatívne ovládanie teploty

innovative temperature controller

Postarajte sa o svoje pohodlie a pomocou inteligentného termostatu nastavte teplotu obytných a pracovných priestorov vo všetkých ročných obdobiach. Termostat vám umožňuje ovládať vykurovacie a chladiace zariadenia s možnosťou ekonomického režimu.

Make yourself comfortable by controlling the temperature in your living and working rooms during all seasons with a smart thermostat. It allows you to control heating and cooling devices and features an eco-function.

pohodlie priestoru

comfort in your room

23



moderné osvetlenie

modern illumination





3D svetlo

3D lamp

Rýchle tempo života prináša množstvo informácií. 3D farebné svetlo je elegantným riešením pre označovanie, nasmerovanie a informovanie. Grafiku vám vyrobíme podľa vašich prání.

The rapid pace of life means you are constantly being bombarded with plenty of information. 3D colour lamp provides an elegant solution for information and direction signs. We can make graphics according to your wishes.



ARX – rozlúčte sa s kľúčmi

ARX – say goodbye to keys

ARX ONE vám umožňuje bezpečný a pohodlný vstup do vášho bytu, domu alebo kancelárie. Potrebný je len ťah prstom a dvere sa otvoria. Funguje ako samostatná jednotka, na ovládanie potrebujete pripojenie k počítaču.

The ARX ONE allows you to gain access to your apartment, house or office securely and conveniently. It takes only a swipe of the finger to unlock the door. It functions as an independent unit and requires no computer connection.

väčšia bezpečnosť

improved security

27



osobitosť

individuality



vytvorte si svoje vlastné

make it your own

Budte iní. Vytvorte si vypínač podľa svojich predstáv. Vybrať si môžete medzi rôznymi farbami rámkov, ktoré vám podľa vašich želaní ozdobíme grafikami alebo nápismi. Vyberte si farbu osvetlenia, ktorá vyhovuje vášmu priestoru.

Be different. Make a switch according to your taste. You can choose between different frame colours and we can decorate them for you with custom graphics or signs. Choose an illumination colour that suits the ambience of your room.



modulárnosť

modularity

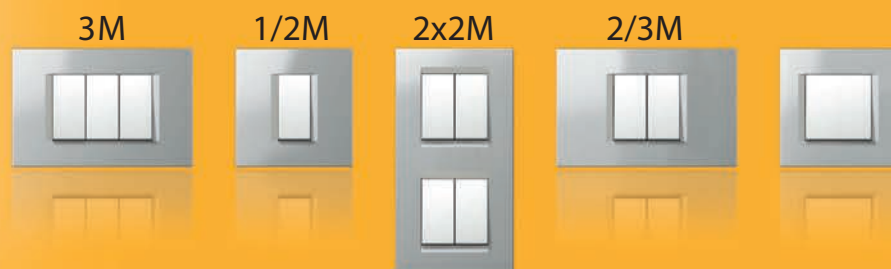

Postarali sme sa o komplexný systém. Nájdete v ňom všetky prvky pre ľubovoľnú konfiguráciu. Základné prvky systému sú moduly. Môžete ich kombinovať vodorovne alebo zvisle.

We have designed a comprehensive system that features a variety of elements, allowing you to create any configuration you wish. The basic elements of the system are modular and can be combined horizontally or vertically.



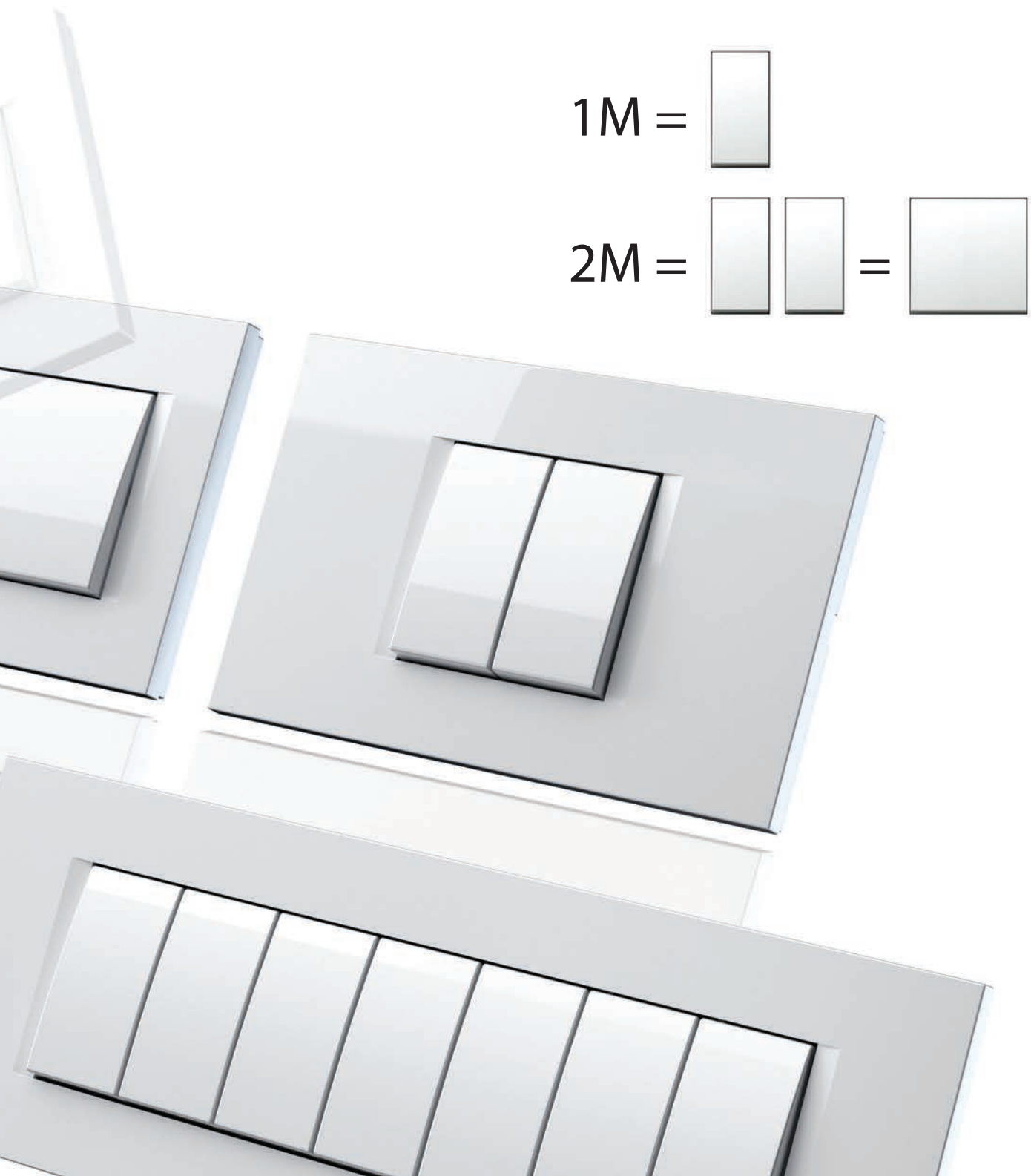
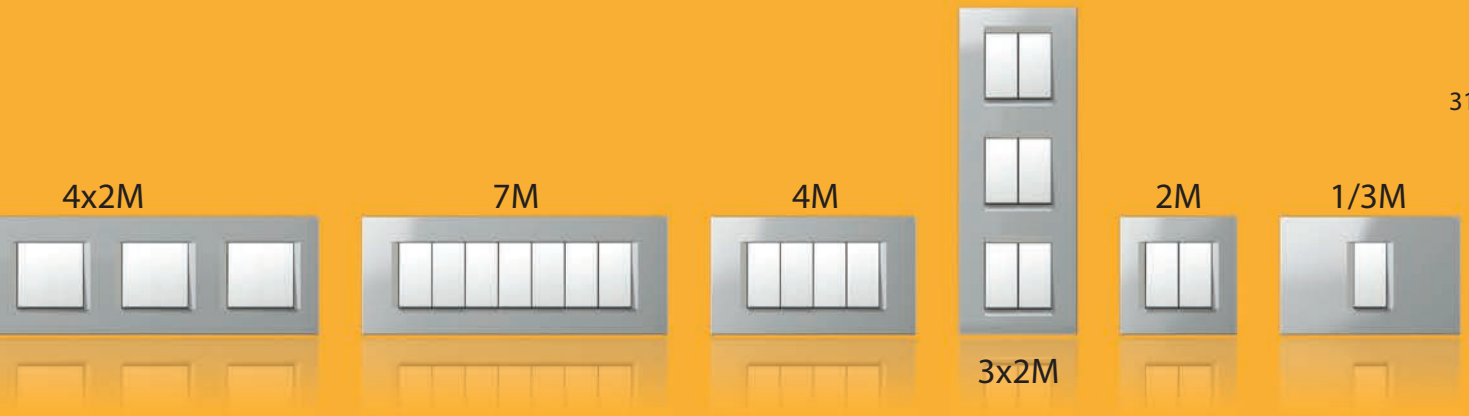

univerzálnosť

universality

System sa vyznačuje dokonalým výberom elementov a jednoduchou inštaláciou. Súpravu spínačov môžete umiestniť do priestoru rôznymi spôsobmi, či už je krabica okrúhla alebo obdĺžniková, samostatná alebo v skupine.

The system features a comprehensive selection of elements and is easy to install. Switch sets can be positioned in many different ways, regardless of whether the box is round or rectangular, individual or serial.



modulmanager.tem.si



Vyskúšajte nástroj »ModulManager«, ktorý vám umožní zostaviť ľubovoľné kombinácie.

Try out the "ModulManager" tool, which will help you put together any combination you want.

riešenia pre 4 spínače

solutions for 4 switches

1/2M



2M



2M



1/3M



2/3M



2/3M



4M



2x2M



2x2M



4x2M



3x2M



funkčnosť functionality

Modul sme vyvinuli pre všetkých, ktorí ocenia premyslene navrhnutý výrobok. Systém vyžaduje menej miesta, keďže v jednom rámičku je možné zostaviť ľubovoľnú kombináciu funkčných elementov. Vhodný je pre nové i renovované priestory.

The Modul was developed for those who can appreciate a thoughtfully designed product. The system takes up less space, as any combination of function elements can be fitted inside the same cover plate. It is suitable for new, as well as renovated buildings.



Modul Soft aj v antibakteriálnej verzii AW.

The Modul Soft is also available in an antibacterial solution AW.

dekoratívne rámy
decorative cover plates

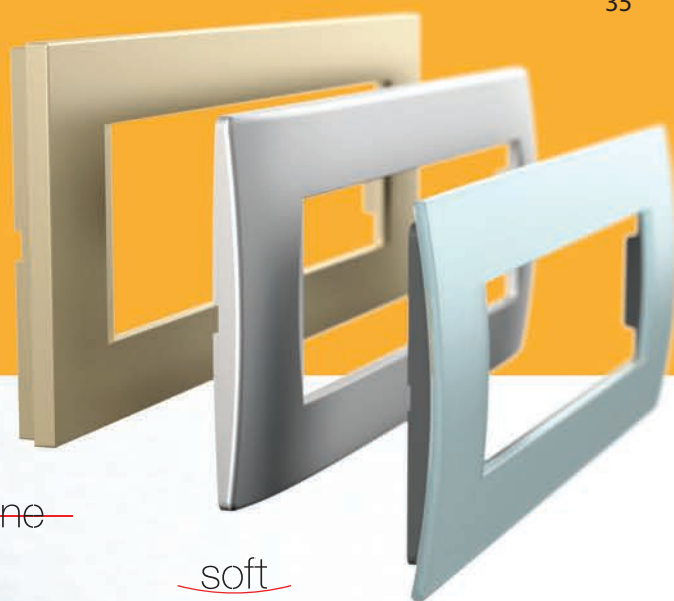

line

soft

PURE



funkčné elementy
function elements

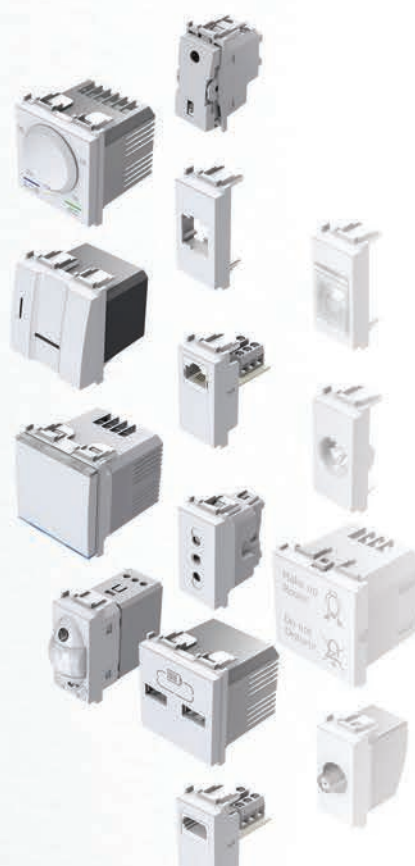

jednoduchost' simplicity

Funkčné elementy jednoducho pripevníte na úchytku. Vyvinuli sme pre vás riešenie „klik-in, klik-out“, ktoré vám skráti čas montáže. Pripojovacie kontakty sú ľahko prístupné z prednej strany.

The function elements are easily fitted inside the mounting frame.
The “klik-in, klik-out” solution we have developed for you will reduce installation time. The connection contacts are easily accessible from the front.

line
soft
PURE

klik-in, klik-out

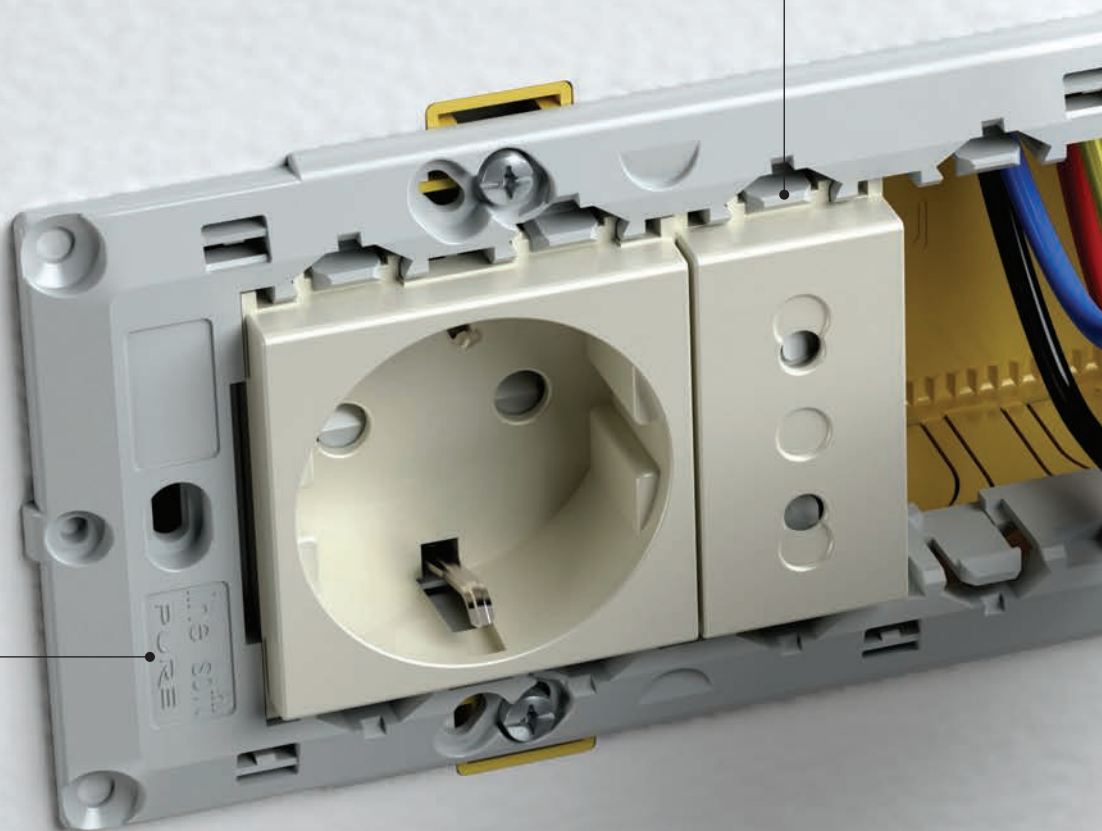

„klik-out“ – jednoducho a rýchlo,
bez skrutkovania.

“klik-out” - simple and quick,
no screws necessary.

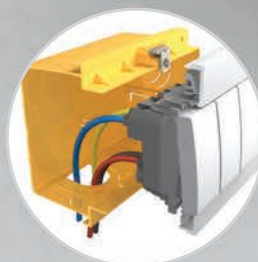

V obdĺžnikových krabiciach je viac
miesta na pripojovacie káble.

Rectangular boxes have more space
for connection wires.

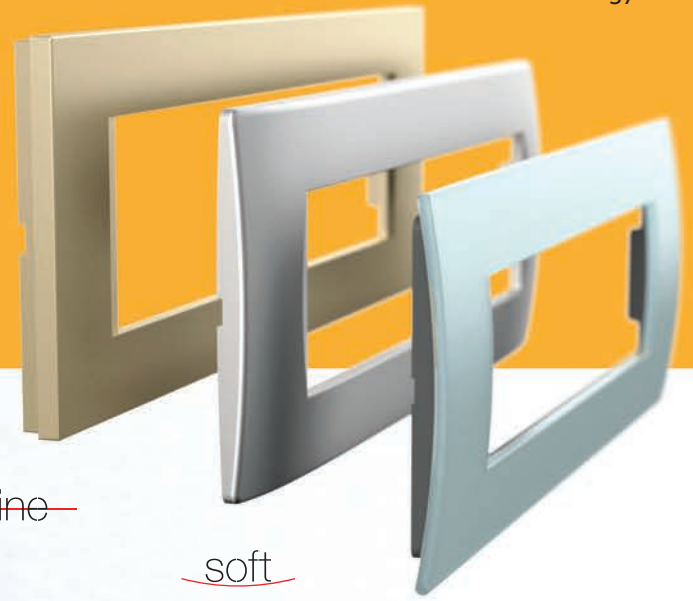
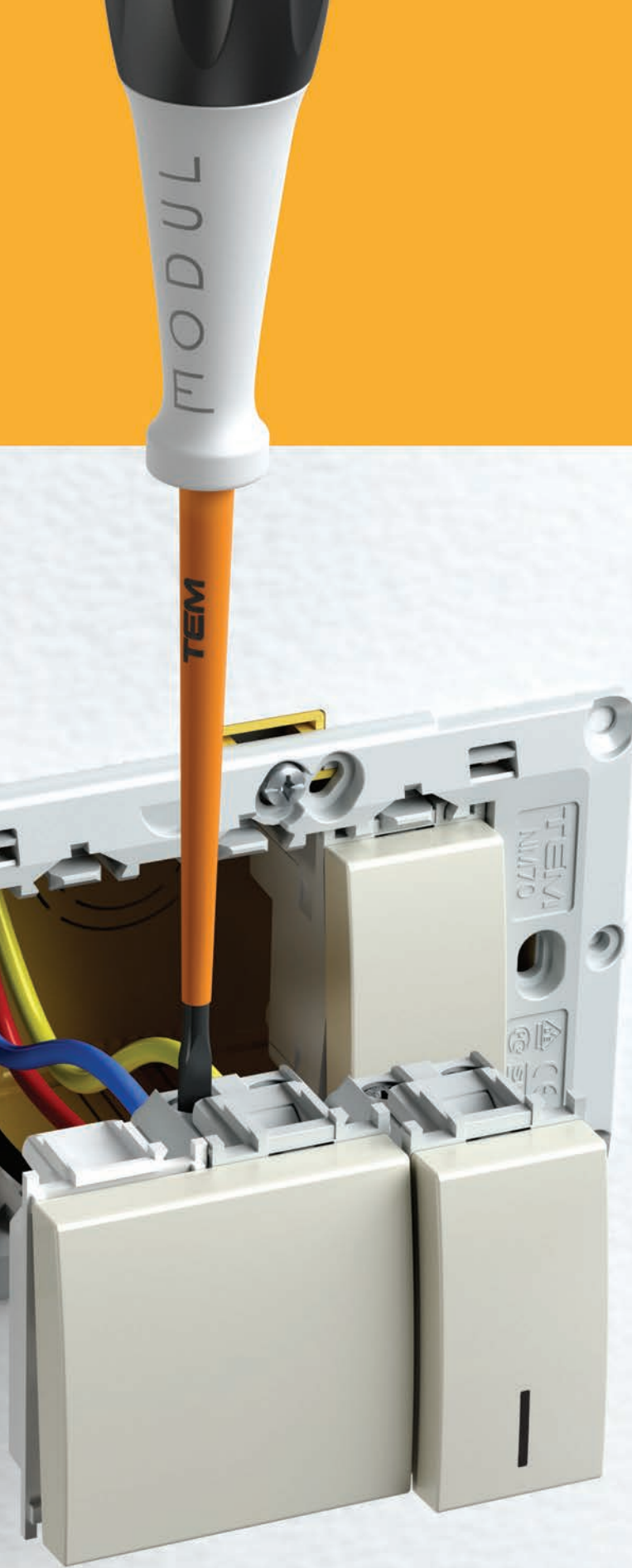

~~line~~

soft

PURE

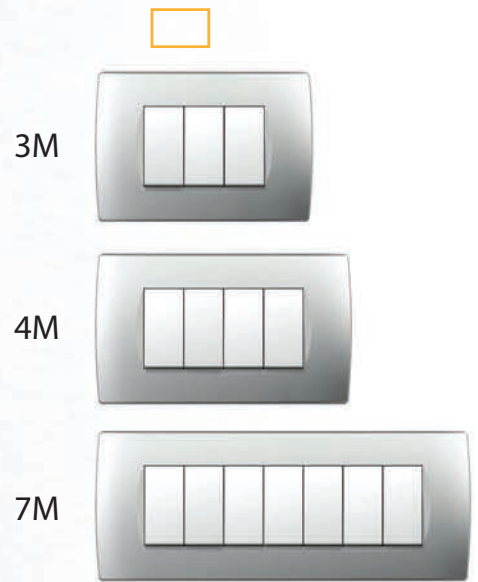

kombinovateľnosť

combinability

Modul vám ponúka veľa možností aj pri použití okrúhlych krabíc. Môžete ich kombinovať vodorovne alebo zvisle, samostatne alebo v skupinách. Kovové úchytky zaručujú vynikajúcu stabilitu aj pri menej šetrnom používaní a sú vhodné pre všetky dekoratívne rámy.

The Modul enables many possibilities even with round boxes. You can combine them horizontally or vertically, individually or in groups. The metal mounting frame ensures excellent stability even with rough use and is suitable for any decorative cover plates.

line
soft
PURE

klik-in, klik-out

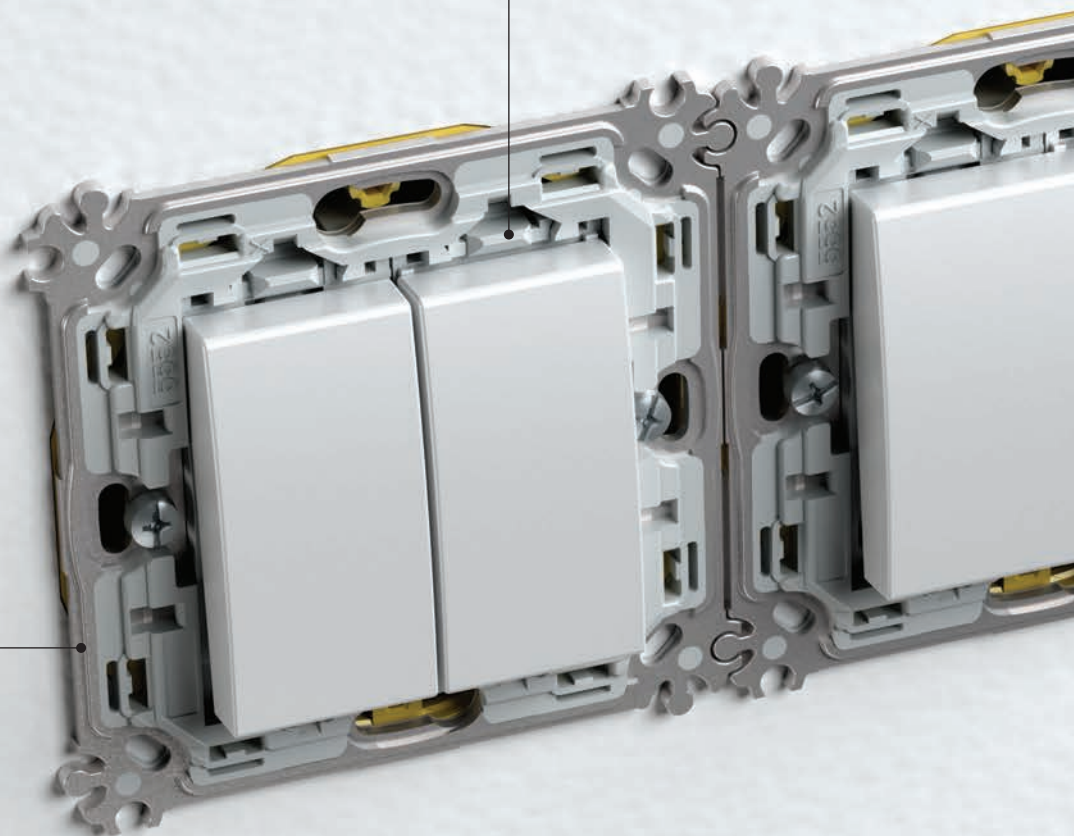

Rovnaký rámik je možné použiť vodorovne alebo zvisle.
The same cover plate can be positioned horizontally or vertically.



Úchytky je možné pripevniť skrutkami alebo svorkami.
Mounting frames can be fixed with screws or claws.



line

soft

PURE



2M



2x2M



3x2M



4x2M



2M montážne rámy je možné ľahko spojiť do skupín.

2M mounting frames are easily joined into groups.

univerzálnost'

universality

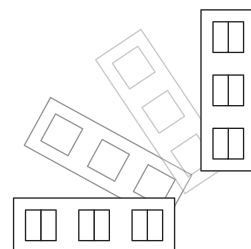
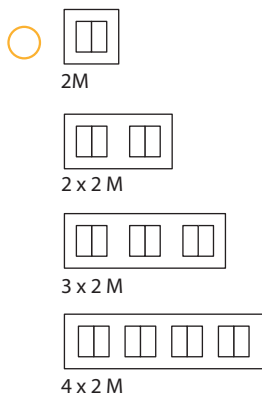
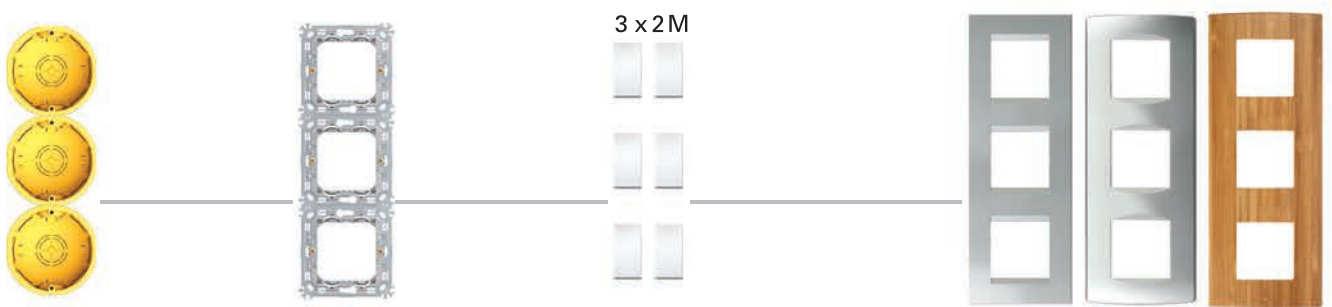
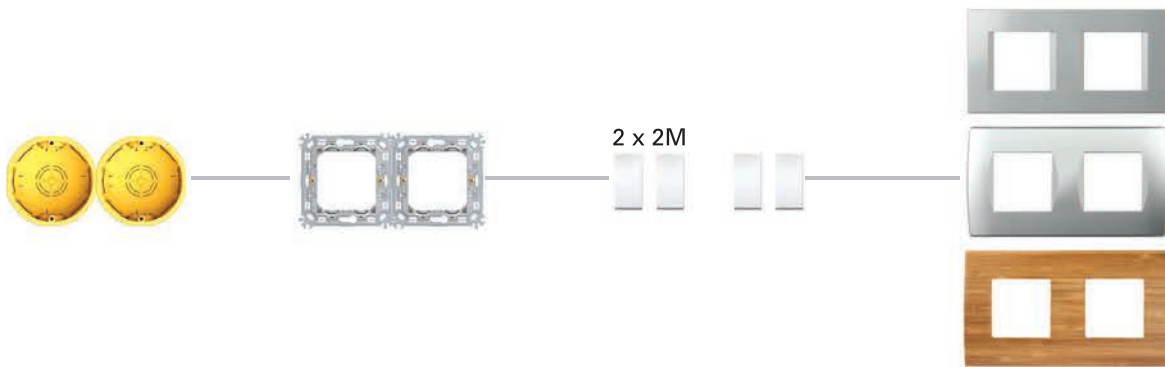
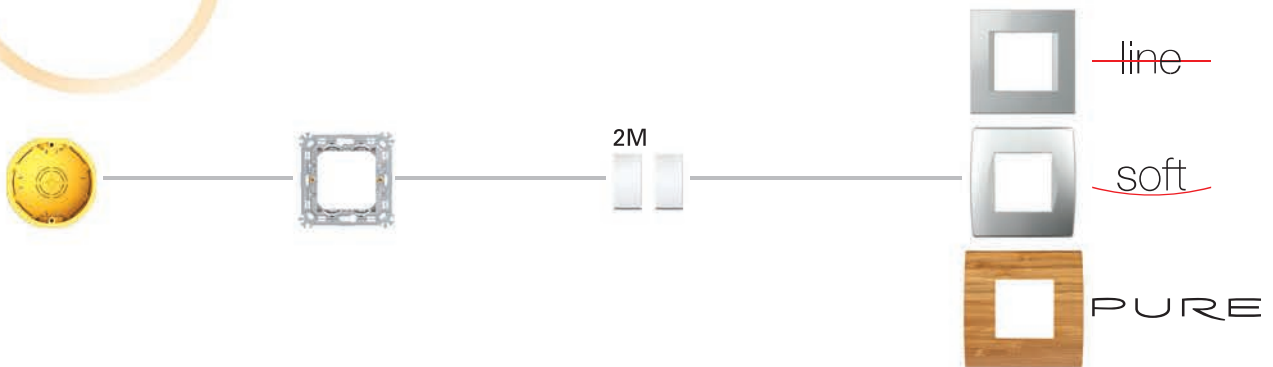

Systém je univerzálny, vhodný na použitie pri okrúhlych a obdĺžnikových krabiciach.

The system is universal and can be fitted in both round and rectangular boxes.

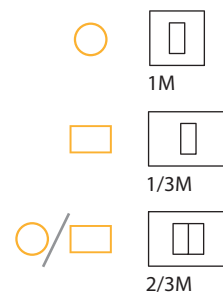
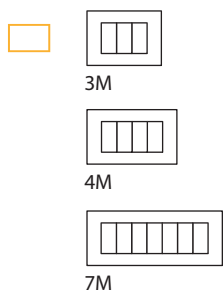
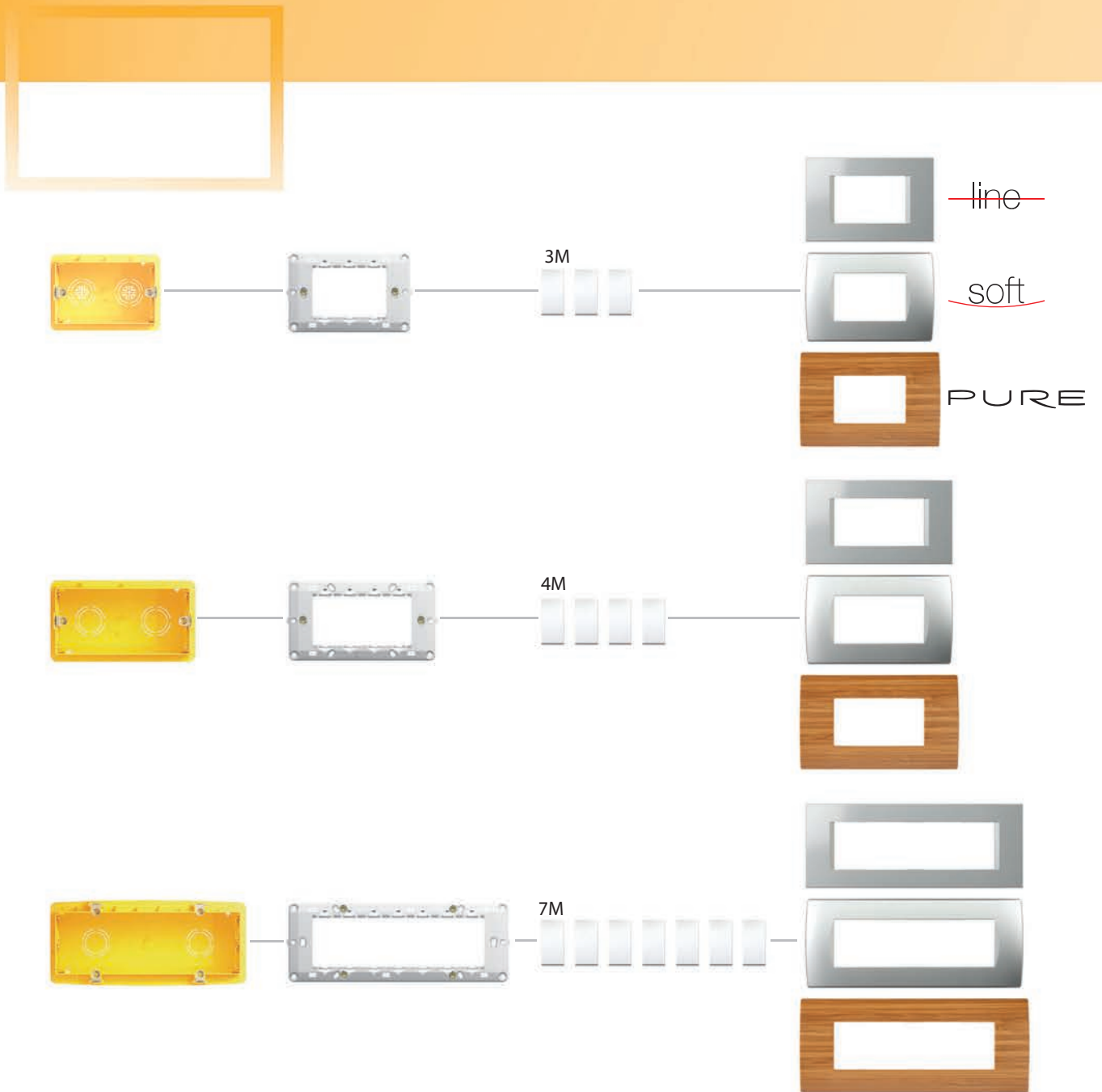

funkčné elementy

function elements

• spínače / switches



• vstup / entrance

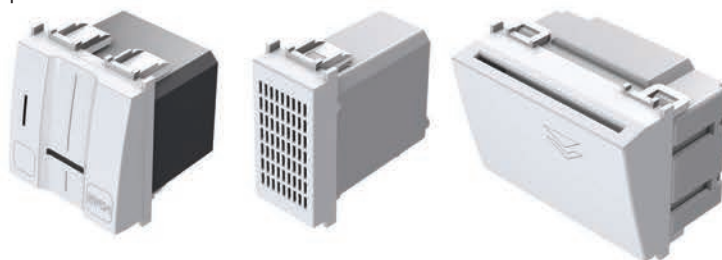

M O D U L

• šetrenie energie / energy saving



Spoločné pripojenie káblov rôznych priemerov.

Reliable connection even when different size of wires are used.

IEC
40000
prepnutí

Dlhá životnosť spínačov a dodržiavanie medzinárodných noriem.

Long-life of switches and adequacy to the international standards.

Postarali sme sa o to, aby ste v rodine Modul našli širokú škálu funkčných elementov. Môžete ich použiť na jednoduchšie, ale aj zložitejšie inštalácie.

We have designed a wide selection of function element for the Modul family. You can use them to design both simple and complex installations.



• zásuvky / sockets

• médiá / entertainment

• osvetlenie / illumination



Všetky zásuvky sú vybavené bezpečnostnou poistkou chráni pred dotykem elementov pod napätím.

All the sockets are equipped with a safety shutters assuring the protection to live contacts.



16 AX
kontakty

Spôľahlivosť prepnutia umožňujú strieborné kontakty.

The switch is highly reliable via its silver rivets contacts.

jedinečný rozsah použiteľnosti

unique range of usability

Modul Soft AW
antibakteriálna verzia /
antibacterial solution



MODUL

CUBO IP20

povrchová montáž
surface mounted boxes



CUBO IP55

povrchová montáž
surface mounted boxes



IP44

zapustené krabice
flush mounted



Zariaďujete domov, kanceláriu alebo dielňu? Modul je vhodný pre obytné aj pracovné priestory, v súkromných aj verejných budovách. Je jedinečný v tom, že spínače a zásuvky umiestnite tam, kde ich potrebujete.

Are you furnishing your home, office or workshop? The Modul is suitable for living as well as working spaces and both private and public buildings. It is unique in that the switches and sockets can be fitted wherever they are needed.

D

tehra
brick



H

dutá stena
hollow wall



B

betón
concrete

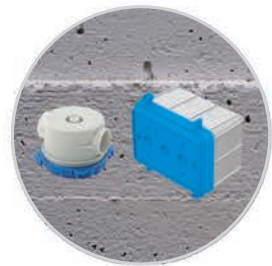

funkčné elementy /
function elements

spínače / switches
zásuvky / sockets
komunikačné prvky
/ communications
senzory / sensors
regulátory / regulators
osvetlenia / illuminations

MA

inštalačné kanály
trunking systems



MO

rozvodné skrine
distribution boards



MT

podlahové krabice
floor boxes



riešenia pre zapustenú montáž

flush mounted solutions

tehla / brick

Modul je vhodný pre všetky typy stien, či už ide o klasickú, dutú alebo betónovú stenu. Inštalácia je jednoduchá a umožňuje vám kombinovať obdĺžnikové alebo okrúhle krabice vo vhodných vzdialenostiach. Použité materiály sú v súlade s vysokými štandardmi.

The Modul is suitable for all wall types and can be used in conventional, hollow wall or concrete constructions. It is easy to install and enables you to combine rectangular or round boxes at the proper distances. The materials used are compliant with high standards.





iné riešenia

other solutions

IP44
zapustená montáž
flush mounted

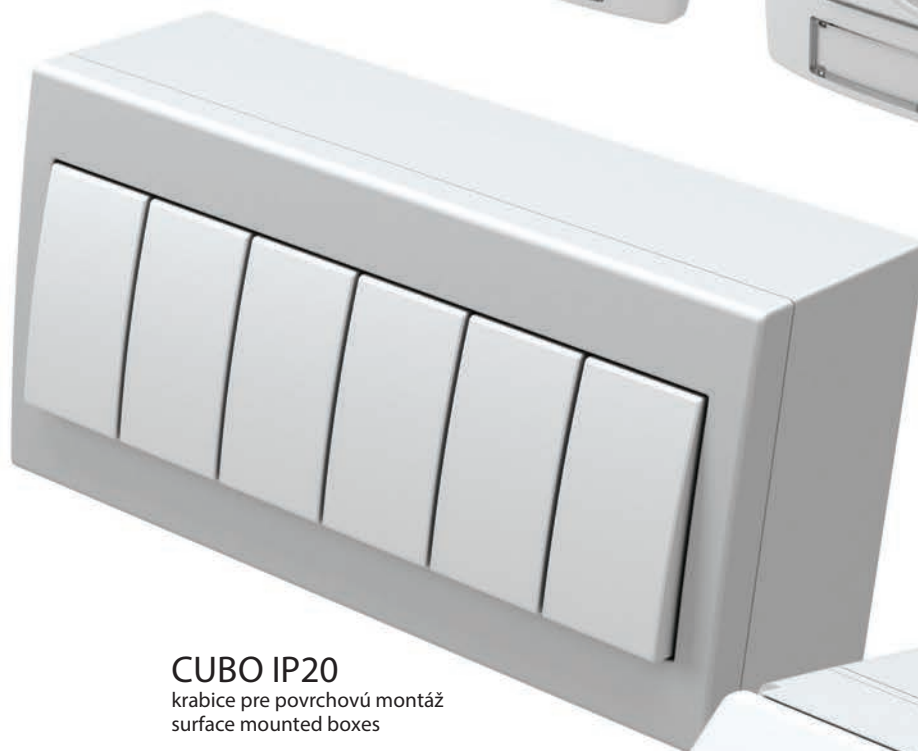

CUBO IP20
krabice pre povrchovú montáž
surface mounted boxes

CUBO IP55
krabice pre povrchovú montáž
surface mounted boxes



Potrebujete spínač pre zapustenú, povrchovú alebo podlahovú montáž?
Modul poskytuje rôzne montážne riešenia, s rôznymi IP ochranami,
v inštalačných kanáloch, rozvodných skrinách alebo podlahových
krabiciach. Volba je na vás.

Do you need switch or socket in flush, surface or floor solution?
The Modul provides different mounting solutions with different IP
protections, for trunking systems, distribution boards or floor boxes.
The choice is yours.



MA

inštalačné kanály
trunking systems

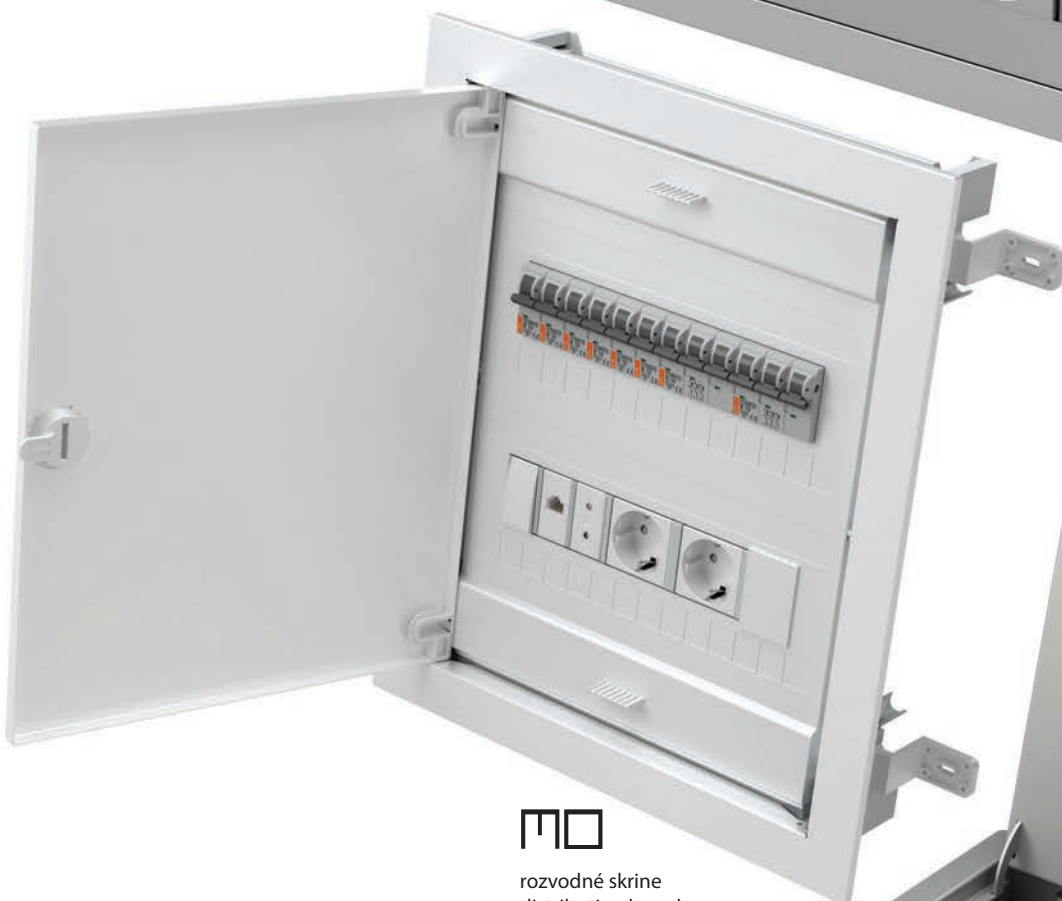

MO

rozvodné skrine
distribution boards



MT

podlahové krabice
floor boxes

technický katalóg

technical catalogue





MODUL

— funkčné moduly
functional modules



54

dizajn
design

PURE

— line
— soft



96

krabice
boxes



118

distribúcia
distribution



140

TEM



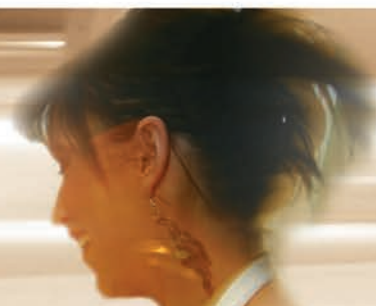

FUNKČNÉ MODULY

FUNCTION ELEMENTS

SPÍNAČE SM

SWITCHES SM



54

TLAČIDLÁ TM

BUTTONS TM



59

OSVETLENIE IA

ILLUMINATION IA



62

ZÁSUVKY VM

SOCKETS VM



64

KOMUNIKAČNÉ PRVKY KM

COMMUNICATIONS KM



68

KOMUNIKAČNÉ PRÍSLUŠENSTVO KA

COMMUNICATION ACCESSORIES KA



74

ELEKTRONIKA EM

ELECTRONICS EM



76

SADY CM

SETS CM



89

ANTIBAKTERIÁLNY PROGRAM AW

ANTIBACTERIAL PROGRAM AW



92

DIZAJN

DESIGN

RÁMIKY PURE OP

COVER PLATES PURE OP



96

RÁMIKY LINE OL

COVER PLATES LINE OL



100

RÁMIKY SOFT OS

COVER PLATES SOFT OS



104

MONTÁŽNE RÁMIKY NM

MOUNTING FRAMES NM



112



SM11

PW

IN

O1

Typ type	názov description	technické údaje technical data	veľkosť size	farba colour	fakultatívny opis 1 optional data 1	fakultatívny opis 2 optional data 2
SM10	SPÍNAČ JEDNOPÓLOVÝ SWITCH 1WAY	16AX 250V~	1M	<input type="checkbox"/> PW biely-lesklý polar white	<input type="checkbox"/> NT neutrálny neutral	01
SM11	SPÍNAČ JEDNOPÓLOVÝ PUSH BUTTON 1WAY	16A 250V~	1M	<input checked="" type="checkbox"/> SB čierny-matný soft touch black	<input type="checkbox"/> IN indikátor indicator	02
SM12	SPÍNAČ JEDNOPÓLOVÝ SWITCH 1WAY	20A 250V~	1M	<input type="checkbox"/> ES strieborný-matný elox silver		03
.	.	.	.	<input type="checkbox"/> IW slonová kosť-lesklý ivory white		.

SPÍNAČ JEDNOPÓLOVÝ 16AX 250V~ 1M



SM10

- spínač bez krytky tlačidla
- 16AX 250V~, typ SM10
- vyhovuje EN 60669-1
- skrutkové upevnenie vodičov 1,5-2,5 mm²



SWITCH 1WAY 16AX 250V~ 1M
- switch without button
- 16AX 250V~, type SM10
- in accordance with EN 60669-1
- screw contacts 1.5-2.5mm²

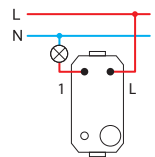

SPÍNAČ JEDNOPÓLOVÝ 16A 250V~ 1M



SM11

- spínač bez krytky tlačidla
- 16A 250V~, typ SM11
- vyhovuje EN 60669-1
- skrutkové upevnenie vodičov 1,5-2,5 mm²



PUSH BUTTON 1WAY 16A 250V~ 1M
- push button without button
- 16A 250V~, type SM11
- in accordance with EN 60669-1
- screw contacts 1.5-2.5mm²

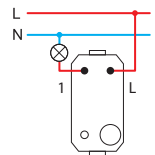

SPÍNAČ JEDNOPÓLOVÝ 20A 250V~ 1M



SM12

- spínač bez krytky tlačidla
- 20A 250V~, typ SM12
- vyhovuje EN 60669-1
- skrutkové upevnenie vodičov 1,5-2,5 mm²



SWITCH 1WAY 20A 250V~ 1M
- switch without button
- 20A 250V~, type SM12
- in accordance with EN 60669-1
- screw contacts 1.5-2.5mm²

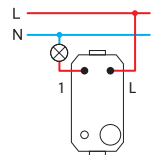

SPÍNAČ DVOJPÓLOVÝ 16AX 250V~ 1M



SM20

- spínač bez krytky tlačidla
- 16AX 250V~, typ SM20
- vyhovuje EN 60669-1
- skrutkové upevnenie vodičov 1,5-2,5 mm²
- iba v kombinácii s krytkou TM15

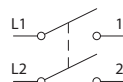

SWITCH 2POLE 16AX 250V~ 1M
- switch without button
- 16AX 250V~, type SM20
- in accordance with EN 60669-1
- screw contacts 1.5-2.5mm²
- only in combination with button TM15

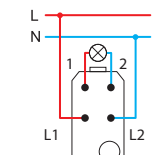

ŽALÚZIOVÝ SPÍNAČ 1-0-2 16AX 250V~ 1M



SM40

- spínač bez krytky tlačidla
- 16AX 250V~, typ SM40
- vyhovuje EN 60669-1
- skrutkové upevnenie vodičov 1,5-2,5 mm²



SWITCH SHUTTERS 1-0-2 16AX 250V~ 1M

- switch without button
- 16AX 250V~, type SM40
- in accordance with EN 60669-1
- screw contacts 1.5-2.5mm²

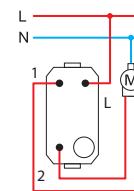

ŽALÚZIOVÝ SPÍNAČ 1-0-2 16A 250V~ 1M



SM41

- spínač bez krytky tlačidla
- 16A 250V~, typ SM41
- vyhovuje EN 60669-1
- skrutkové upevnenie vodičov 1,5-2,5 mm²

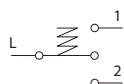

PUSH BUTTON SHUTTERS 1-0-2 16A 250V~ 1M

- push button without button
- 16A 250V~, type SM41
- in accordance with EN 60669-1
- screw contacts 1.5-2.5mm²

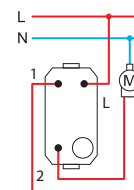

STRIEDAVÝ SPÍNAČ 16AX 250V~ 1M



SM60

- spínač bez krytky tlačidla
- 16AX 250V~, typ SM60
- vyhovuje EN 60669-1
- skrutkové upevnenie vodičov 1,5-2,5 mm²

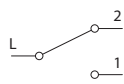

SWITCH 2WAY 16AX 250V~ 1M

- switch without button
- 16AX 250V~, type SM60
- in accordance with EN 60669-1
- screw contacts 1.5-2.5mm²

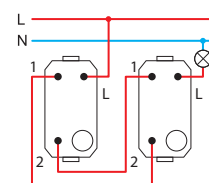

STRIEDAVÝ SPÍNAČ 16A 250V~ 1M



SM61

- spínač bez krytky tlačidla
- 16A 250V~, typ SM61
- vyhovuje EN 60669-1
- skrutkové upevnenie vodičov 1,5-2,5 mm²

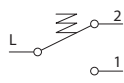

PUSH BUTTON 2WAY 16A 250V~ 1M

- push button without button
- 16A 250V~, type SM61
- in accordance with EN 60669-1
- screw contacts 1.5-2.5mm²

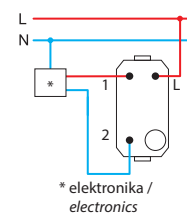

KRÍŽOVÝ SPÍNAČ 16AX 250V~ 1M



SM70

- spínač bez krytky tlačidla
- 16AX 250V~, typ SM70
- vyhovuje EN 60669-1
- skrutkové upevnenie vodičov 1,5-2,5 mm²

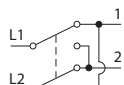

SWITCH INTERMEDIATE 16AX 250V~ 1M

- switch without button
- 16AX 250V~, type SM70
- in accordance with EN 60669-1
- screw contacts 1.5-2.5mm²

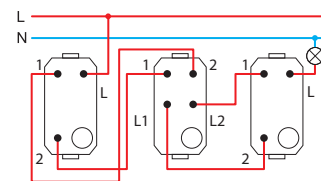

1M = 22,5 x 45
2M = 45 x 45

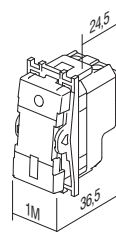
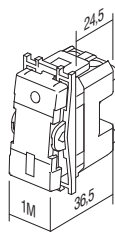



□ PW biely-lesklý
polar white



■ SB čierny-matný
soft touch black



□ ES strieborný-matný
elox silver



□ IW slonová kost-lesklý
ivory white

SPÍNAČ JEDNOPÓLOVÝ 16AX 250V~ 1M



- SM10PW
- SM10SB
- SM10ES
- SM10IW

- 16AX 250V~, typ SM10
- vyhovuje EN 60669-1
- skrutkové upevnenie vodičov 1,5-2,5 mm²
- vymeniteľná krytka na spínač

SWITCH 1WAY 16AX 250V~ 1M

- 16AX 250V~, type SM10
- in accordance with EN 60669-1
- screw contacts 1.5-2.5 mm²
- replaceable button



SPÍNAČ JEDNOPÓLOVÝ 16AX 250V~ 1M_IN



- SM10PWIN
- SM10SBIN
- SM10ESIN
- SM10IWIN

- IN indikátor
- 16AX 250V~, typ SM10
- vyhovuje EN 60669-1
- skrutkové upevnenie vodičov 1,5-2,5 mm²
- výbojka nie je priložená
- vymeniteľná krytka na spínač

SWITCH 1WAY 16AX 250V~ 1M __ IN

- IN indicator
- 16AX 250V~, type SM10
- in accordance with EN 60669-1
- screw contacts 1.5-2.5 mm²
- lamp is not included
- replaceable button



SPÍNAČ JEDNOPÓLOVÝ 16A 250V~ 1M



- SM11PW
- SM11SB
- SM11ES
- SM11IW

- 16A 250V~, typ SM11
- vyhovuje EN 60669-1
- skrutkové upevnenie vodičov 1,5-2,5 mm²
- vymeniteľná krytka na spínač

PUSH BUTTON 1WAY 16A 250V~ 1M

- 16A 250V~, type SM11
- in accordance with EN 60669-1
- screw contacts 1.5-2.5 mm²
- replaceable button



SPÍNAČ JEDNOPÓLOVÝ 16A 250V~ 1M_IN01



- SM11PWIN01
- SM11SBIN01
- SM11ESIN01
- SM11IWIN01

- IN 01 indikátor zvonca
- 16A 250V~, typ SM11
- vyhovuje EN 60669-1
- skrutkové upevnenie vodičov 1,5-2,5 mm²
- výbojka nie je priložená
- vymeniteľná krytka na spínač

PUSH BUTTON 1WAY 16A 250V~ 1M __ IN 01

- IN 01 indicator bell
- 16A 250V~, type SM11
- in accordance with EN 60669-1
- screw contacts 1.5-2.5 mm²
- lamp is not included
- replaceable button



SPÍNAČ JEDNOPÓLOVÝ 16A 250V~ 1M_IN02



- SM11PWIN02
- SM11SBIN02
- SM11ESIN02
- SM11IWIN02

- IN 02 indikátor svetlo
- 16A 250V~, typ SM11
- vyhovuje EN 60669-1
- skrutkové upevnenie vodičov 1,5-2,5 mm²
- výbojka nie je priložená
- vymeniteľná krytka na spínač

PUSH BUTTON 1WAY 16A 250V~ 1M__IN 02

- IN 02 indicator light
- 16A 250V~, type SM11
- in accordance with EN 60669-1
- screw contacts 1.5-2.5 mm²
- lamp is not included
- replaceable button



SPÍNAČ DVOJPÓLOVÝ 16AX 250V~ 1M__NT 03



- SM20PWNT03
- SM20SBNT03
- SM20ESNT03
- SM20IWNT03

- NT 03 neutrál 0-1
- 16AX 250V~, typ SM20
- vyhovuje EN 60669-1
- skrutkové upevnenie vodičov 1,5-2,5 mm²
- vymeniteľná krytka na spínač

SWITCH 2POLE 16AX 250V~ 1M __ NT 03

- NT 03 neutral 0-1
- 16AX 250V~, type SM20
- in accordance with EN 60669-1
- screw contacts 1.5-2.5 mm²
- replaceable button



SPÍNAČ DVOJPÓLOVÝ 16AX 250V~ 1M_IN



- SM20PWIN
- SM20SBIN
- SM20ESIN
- SM20IWIN

- IN indikátor
- 16AX 250V~, typ SM20
- vyhovuje EN 60669-1
- skrutkové upevnenie vodičov 1,5-2,5 mm²
- výbojka nie je priložená
- vymeniteľná krytka na spínač

SWITCH 2POLE 16AX 250V~ 1M __ IN

- IN indicator
- 16AX 250V~, type SM10
- in accordance with EN 60669-1
- screw contacts 1.5-2.5 mm²
- lamp is not included
- replaceable button



ŽALÚZIOVÝ SPÍNAČ 1-0-2 16AX 250V~ 1M__NT 10



- SM40PWNT10
- SM40SBNT10
- SM40ESNT10
- SM40IWNT10

- NT 10 neutrál 1-0-2
- 16AX 250V~, typ SM40
- vyhovuje EN 60669-1
- skrutkové upevnenie vodičov 1,5-2,5 mm²
- vymeniteľná krytka na spínač

SWITCH SHUTTERS 1-0-2 16AX 250V~ 1M __ NT 10

- NT 10 neutral 1-0-2
- 16AX 250V~, type SM40
- in accordance with EN 60669-1
- screw contacts 1.5-2.5mm²
- replaceable button



ŽALÚZIOVÝ SPÍNAČ 1-0-2 16A 250V~ 1M__NT 10



- SM41PWNT10
- SM41SBNT10
- SM41ESNT10
- SM41IWNT10

- NT 10 neutrál 1-0-2
- 16A 250V~, typ SM41
- vyhovuje EN 60669-1
- skrutkové upevnenie vodičov 1,5-2,5 mm²
- vymeniteľná krytka na spínač

PUSH BUTTON SHUTTERS 1-0-2 16A 250V~ 1M __ NT 10

- NT 10 neutral 1-0-2
- 16A 250V~, type SM41
- in accordance with EN 60669-1
- screw contacts 1.5-2.5mm²
- replaceable button



STRIEDAVÝ SPÍNAČ 16AX 250V~ 1M



- SM60PW
- SM60SB
- SM60ES
- SM60IW

- 16AX 250V~, typ SM60
- vyhovuje EN 60669-1
- skrutkové upevnenie vodičov 1,5-2,5 mm²
- vymeniteľná krytka na spínač

SWITCH 2WAY 16AX 250V~ 1M

- 16AX 250V~, type SM60
- in accordance with EN 60669-1
- screw contacts 1.5-2.5 mm²
- replaceable button



STRIEDAVÝ SPÍNAČ 16A 250V~ 1M



- SM61PW
- SM61SB
- SM61ES
- SM61IW

- 16A 250V~, typ SM61
- vyhovuje EN 60669-1
- skrutkové upevnenie vodičov 1,5-2,5 mm²
- vymeniteľná krytka tlačidla

PUSH BUTTON 2WAY 16A 250V~ 1M

- 16A 250V~, type SM61
- in accordance with EN 60669-1
- screw contacts 1.5-2.5 mm²
- replaceable button



STRIEDAVÝ SPÍNAČ SO ŠNÚRKOU 16A 250V~ 1M __ CD



- SM62PWCD
- SM62SBCD
- SM62ESCD
- SM62IWCD

- CD indikátor + šnúrka
- šnúrka dĺžky 1.5m
- 16A 250V~, typ SM62
- vyhovuje EN 60669-1
- skrutkové upevnenie vodičov 1,5-2,5 mm²

PUSH BUTTON 2WAY WITH CORD 16A 250V~ 1M __ CD

- CD indicator+cord
- cord length 1.5m
- 16A 250V~, type SM62
- in accordance with EN 60669-1
- screw contacts 1.5-2.5mm²



KRÍŽOVÝ SPÍNAČ 16AX 250V~ 1M



- SM70PW
- SM70SB
- SM70ES
- SM70IW

- 16AX 250V~, typ SM70
- vyhovuje EN 60669-1
- skrutkové upevnenie vodičov 1,5-2,5 mm²
- vymeniteľná krytka tlačidla

SWITCH INTERMEDIATE 16AX 250V~ 1M

- 16AX 250V~, type SM70
- in accordance with EN 60669-1
- screw contacts 1.5-2.5 mm²
- replaceable button



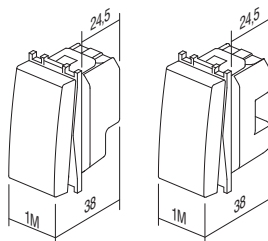

1M = 22,5 x 45
2M = 45 x 45



B U T T O N S T M



Typ type	názov description	veľkosť size	farba colour	fakultatívny opis 1 optional data 1	fakultatívny opis 2 optional data 2
TM11	KRYTKA NA SPÍNAČ BUTTON	1M	<input type="checkbox"/> PW biely-lesklý polar white <input type="checkbox"/> SB čierne-matné soft touch black <input type="checkbox"/> ES strieborný-matný elox silver <input type="checkbox"/> IW slonová kosť-lesklý ivory white	<input type="checkbox"/> NT neutrálny neutral <input type="checkbox"/> IN indikátor indicator	 01  02  03 : : :
TM12	KRYTKA NA SPÍNAČ BUTTON	2M			
TM21	VÝPLŇ BLANK	1M			
.	.	.			.
.	.	.			.
.	.	.			.

KRYTKA NA SPÍNAČ 1M



- TM11PW
- TM11SB
- TM11ES
- TM11IW

- vymeniteľná krytka na spínač veľkosti 1M
- vyhovuje EN 60669-1

BUTTON 1M

- replaceable button 1M
- in accordance with EN 60669-1



KRYTKA NA SPÍNAČ 1M INDIKÁTOR



- TM11PWIN
- TM11SBIN
- TM11ESIN
- TM11IWIN

- vymeniteľná krytka na spínač 1M
- vyhovuje EN 60669-1

BUTTON 1M INDICATOR

- replaceable button 1M
- in accordance with EN 60669-1



KRYTKA NA SPÍNAČ 2M



- TM12PW
- TM12SB
- TM12ES
- TM12IW

- vymeniteľná krytka na spínač veľkosti 2M s úchytkou tlačidla
- používa sa pri nadstavbe spínača alebo krytky spínača veľkosti 1M na veľkosť 2M
- vyhovuje EN 60669-1

BUTTON 2M

- replaceable button 2M with button carrier
- to upgrade switch or push button from size 1M to size 2M
- in accordance with EN 60669-1



KRYTKA NA SPÍNAČ 2M INDIKÁTOR

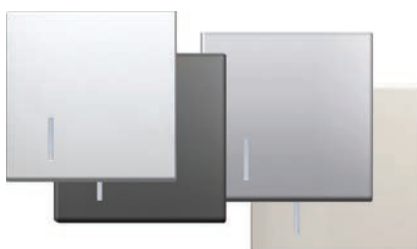

- TM12PWIN
- TM12SBIN
- TM12ESIN
- TM12IWIN

- vymeniteľná krytka na spínač veľkosti 2M s úchytkou tlačidla
- používa sa pri nadstavbe spínača alebo krytky spínača veľkosti 1M na veľkosť 2M
- vyhovuje EN 60669-1

BUTTON 2M INDICATOR

- replaceable button 2M with button carrier
- to upgrade switch or push button from size 1M to size 2M
- in accordance with EN 60669-1



KRYTKA NA SPÍNAČ 2M S POPISNÝM ŠTÍTKOM

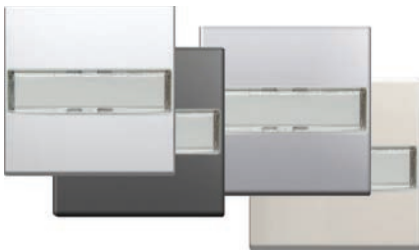

- TM13PWIL
- TM13SBIL
- TM13ESIL
- TM13IWIL

- vymeniteľná krytka na spínač veľkosti 2M s úchytkou krytky tlačidla
 - používa sa pri nadstavbe spínača alebo krytky spínača veľkosti 1M na veľkosť 2M
 - vyhovuje EN 60669-1

BUTTON 2M WITH INSCRIPTION PLATE
 - replaceable button 2M with button carrier
 - to upgrade switch or push button from size 1M to size 2M
 - in accordance with EN 60669-1



KRYTKA NA SPÍNAČ 1M DVOJPÓLOVÉ



- TM15PW
- TM15SB
- TM15ES
- TM15IW

- vymeniteľná krytka na spínač veľkosti 1M
 - iba v kombinácii s mechanizmom SM20
 - vyhovuje EN 60669-1

BUTTON 1M 2POLE
 - replaceable button 1M
 - only in combination with mechanism SM20
 - in accordance with EN 60669-1



VÝPLŇ 1M



- TM21PW
- TM21SB
- TM21ES
- TM21IW

- na vyplňovanie prázdnych miest
 - vyhovuje EN 60669-1

BLANK 1M
 - blank modul to fill up empty spaces
 - in accordance with EN 60669-1



VÝPLŇ 2M

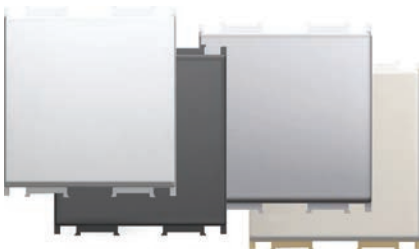

- TM22PW
- TM22SB
- TM22ES
- TM22IW

- na vyplňovanie prázdnych miest
 - vyhovuje EN 60669-1

BLANK 2M
 - blank modul to fill up empty spaces
 - in accordance with EN 60669-1



PRIECHODKA 1M

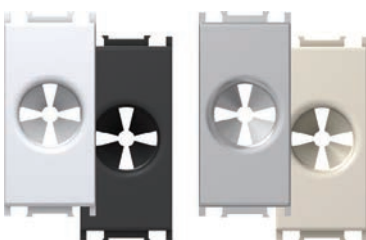

- TM31PW
- TM31SB
- TM31ES
- TM31IW

- káblová priechodka
 - vyhovuje EN-60669-1

CABLE OUTLET 1M
 - outlet for cable
 - in accordance with EN-60669-1



1M = 22,5 x 45
 2M = 45 x 45

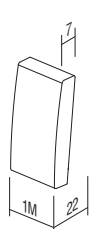

TM11
 TM15

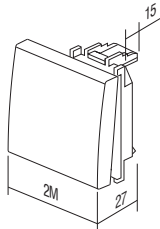

TM12
 TM13

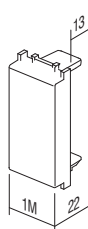

TM21

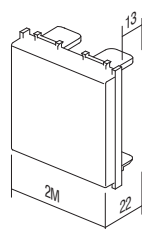

TM22

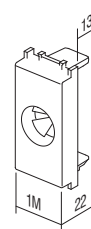

TM31

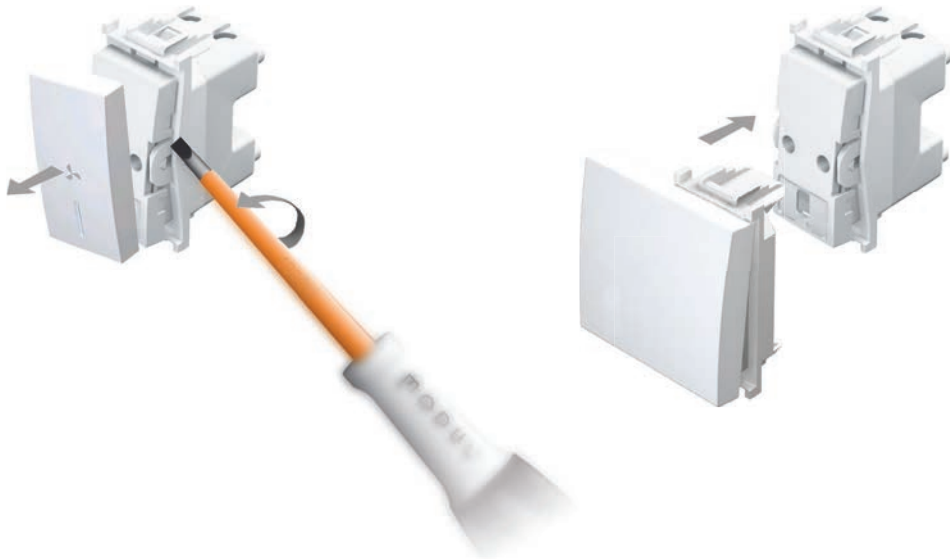

LASEROVÁ POTLAČ KRYTIEK NA SPÍNAČE

- laserová potlač ľubovoľných symbolov na označené miesta
 - štandardné symboly z ponuky, ostatné na objednávku
 LASER PRINT ON BUTTONS
 - laser print of any graphics on marked locations
 - standard symbols from stock, other on request

1M	2M
A	A D G
B	B E H
C	C F I

SYMBOLY

SYMBOLS

01	02	03	04	05	06	07	08	09	10	11	12	20	21	22	23
24	25	26	27	28	29	30	31	32	33	34	35	36	37	38	39
					OFF	ON					AC				
40	41	42	43	44	45	46	47	48							

ŠTANDARDNÉ SYMBOLY

STANDARD SYMBOLS





IA20

WH

Typ type	názov description	technické údaje technical data	farba colour
IA10	VÝBOJKA NEON LAMP	230V~ 0,34W	<input type="checkbox"/> WH biela white
IA20	ŽIARIVKA LED LED LAMP	230V~ 0,40W	<input checked="" type="checkbox"/> BL modrá blue
IA21	ŽIARIVKA LED LED LAMP	24V AC/DC 0,20W	<input checked="" type="checkbox"/> RD červená red
.	.	.	<input checked="" type="checkbox"/> GR zelená green
.	.	.	<input checked="" type="checkbox"/> OR oranžová orange

VÝBOJKA 230V~ 0,34W



IA10OR

- na indikáciu, osvetlenie alebo trvalé osvetlenie spínača
- v kombinácii s tlačidlom s indikátorom

NEON LAMP 230V~ 0,34W

- for indication, illumination or constant illumination of switch
- in combination with button with indicator

ŽIARIVKA LED 230V AC/DC 0,40W



IA20WH
 IA20GR
 IA20RD
 IA20BL

- na indikáciu, osvetlenie alebo trvalé osvetlenie spínača
- v kombinácii s tlačidlom s indikátorom

LED LAMP 230V AC/DC 0,40W

- for indication, illumination or constant illumination of switch
- in combination with button with indicator

ŽIARIVKA LED 24V AC/DC 0,20W



IA21RD

- na indikáciu, osvetlenie alebo trvalé osvetlenie spínača
- v kombinácii s tlačidlom s indikátorom

LED LAMP 24V AC/DC 0,20W

- for indication, illumination or constant illumination of switch
- in combination with button with indicator

ŽIARIVKA LED 12V AC/DC 0,10W



IA22RD

- na indikáciu, osvetlenie alebo trvalé osvetlenie spínača
- v kombinácii s tlačidlom s indikátorom

LED LAMP 12V AC/DC 0,10W

- for indication, illumination or constant illumination of switch
- in combination with button with indicator

I L L U M I N A T I O N I A

Indikácia / *
IndicationPodsvietenie /
IlluminationTrvalé osvetlenie / *
Constant illumination

SM10, 11, 12

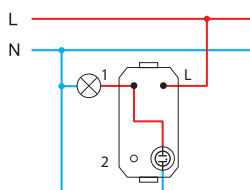

SM10, 11, 12

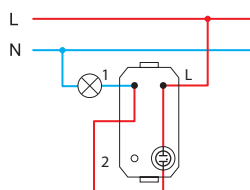

SM10, 11, 12

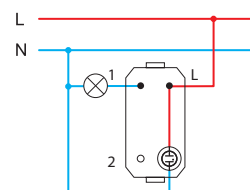

SM60 + SM60

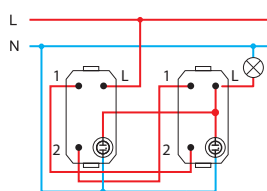

SM60 + SM60

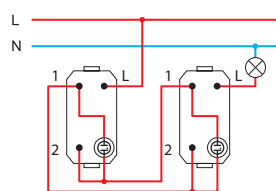

SM60 + SM60

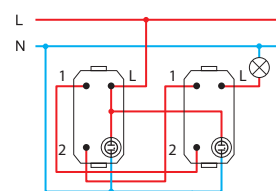

SM60 + SM70 + SM60

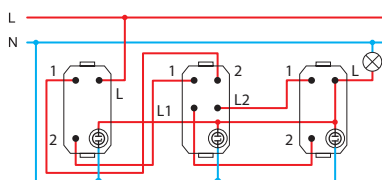

SM60 + SM70 + SM60

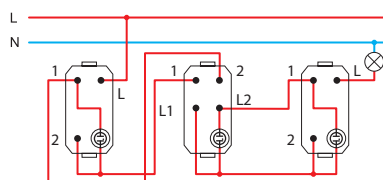

SM60 + SM70 + SM60

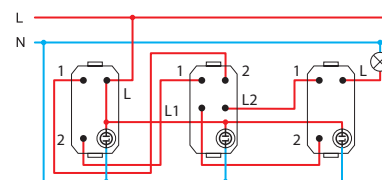

SM20

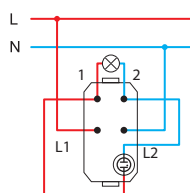

SM20

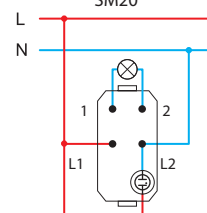

* zapojenia vhodné pre úsporné (CFL) žiarivky / wiring schemes for compact fluid lamp (CFL)

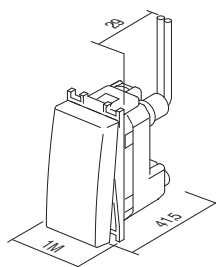
1M = 22,5 x 45
2M = 45 x 45



VM11

PT

Typ type	názov description	technické údaje technical data	veľkosť size	farba colour																								
VM10	ZÁSUVKA SCHUKO+KS SOCKET SCHUKO+KS	2P+E 16A 250V~	2M	<table border="0"> <tr> <td><input type="checkbox"/> PW</td> <td>biely-lesklý polar white</td> <td><input type="checkbox"/> PT</td> <td>biela + transparentná white+transparent</td> <td><input type="checkbox"/> PP</td> <td>biela+biela white+white</td> </tr> </table>	<input type="checkbox"/> PW	biely-lesklý polar white	<input type="checkbox"/> PT	biela + transparentná white+transparent	<input type="checkbox"/> PP	biela+biela white+white																		
<input type="checkbox"/> PW	biely-lesklý polar white	<input type="checkbox"/> PT	biela + transparentná white+transparent	<input type="checkbox"/> PP	biela+biela white+white																							
VM11	ZÁSUVKA SCHUKO+KS+KRYT SOCKET SCHUKO+KS+COVER	2P+E 16A 250V~	2M	<table border="0"> <tr> <td><input checked="" type="checkbox"/> SB</td> <td>čierna- matná soft touch black</td> <td><input checked="" type="checkbox"/> BT</td> <td>čierna + transparentná soft touch black+transparent</td> <td><input checked="" type="checkbox"/> BB</td> <td>čierna+čierna soft touch black+black</td> </tr> <tr> <td><input type="checkbox"/> ES</td> <td>strieborný-matný elox silver</td> <td><input type="checkbox"/> ST</td> <td>strieborná + transparentná silver+transparent</td> <td><input type="checkbox"/> SS</td> <td>strieborná+strieborná silver+silver</td> </tr> </table>	<input checked="" type="checkbox"/> SB	čierna- matná soft touch black	<input checked="" type="checkbox"/> BT	čierna + transparentná soft touch black+transparent	<input checked="" type="checkbox"/> BB	čierna+čierna soft touch black+black	<input type="checkbox"/> ES	strieborný-matný elox silver	<input type="checkbox"/> ST	strieborná + transparentná silver+transparent	<input type="checkbox"/> SS	strieborná+strieborná silver+silver												
<input checked="" type="checkbox"/> SB	čierna- matná soft touch black	<input checked="" type="checkbox"/> BT	čierna + transparentná soft touch black+transparent	<input checked="" type="checkbox"/> BB	čierna+čierna soft touch black+black																							
<input type="checkbox"/> ES	strieborný-matný elox silver	<input type="checkbox"/> ST	strieborná + transparentná silver+transparent	<input type="checkbox"/> SS	strieborná+strieborná silver+silver																							
VM20	ZÁSUVKA EURO+KS SOCKET EURO+KS	2P 10A 250V~	1M	<table border="0"> <tr> <td><input type="checkbox"/> IW</td> <td>slonová kosť-lesklý ivory white</td> <td><input type="checkbox"/> IT</td> <td>slonová kosť +transparentná ivory+transparent</td> <td><input type="checkbox"/> II</td> <td>slonová kosť+slonová kosť ivory+ivory</td> </tr> <tr> <td><input type="checkbox"/> RD</td> <td>červená red</td> <td><input type="checkbox"/> RT</td> <td>červená+transparentná red+transparent</td> <td><input type="checkbox"/> RR</td> <td>červená+červená red+red</td> </tr> <tr> <td><input type="checkbox"/> GR</td> <td>zelená green</td> <td><input type="checkbox"/> GT</td> <td>zelená+transparentná green+transparent</td> <td><input type="checkbox"/> GG</td> <td>zelená+zelená green+green</td> </tr> <tr> <td><input type="checkbox"/> OR</td> <td>oranžová orange</td> <td><input type="checkbox"/> OT</td> <td>oranžová+transparentná orange+transparent</td> <td><input type="checkbox"/> OO</td> <td>oranžová+oranžová orange+orange</td> </tr> </table>	<input type="checkbox"/> IW	slonová kosť-lesklý ivory white	<input type="checkbox"/> IT	slonová kosť +transparentná ivory+transparent	<input type="checkbox"/> II	slonová kosť+slonová kosť ivory+ivory	<input type="checkbox"/> RD	červená red	<input type="checkbox"/> RT	červená+transparentná red+transparent	<input type="checkbox"/> RR	červená+červená red+red	<input type="checkbox"/> GR	zelená green	<input type="checkbox"/> GT	zelená+transparentná green+transparent	<input type="checkbox"/> GG	zelená+zelená green+green	<input type="checkbox"/> OR	oranžová orange	<input type="checkbox"/> OT	oranžová+transparentná orange+transparent	<input type="checkbox"/> OO	oranžová+oranžová orange+orange
<input type="checkbox"/> IW	slonová kosť-lesklý ivory white	<input type="checkbox"/> IT	slonová kosť +transparentná ivory+transparent	<input type="checkbox"/> II	slonová kosť+slonová kosť ivory+ivory																							
<input type="checkbox"/> RD	červená red	<input type="checkbox"/> RT	červená+transparentná red+transparent	<input type="checkbox"/> RR	červená+červená red+red																							
<input type="checkbox"/> GR	zelená green	<input type="checkbox"/> GT	zelená+transparentná green+transparent	<input type="checkbox"/> GG	zelená+zelená green+green																							
<input type="checkbox"/> OR	oranžová orange	<input type="checkbox"/> OT	oranžová+transparentná orange+transparent	<input type="checkbox"/> OO	oranžová+oranžová orange+orange																							

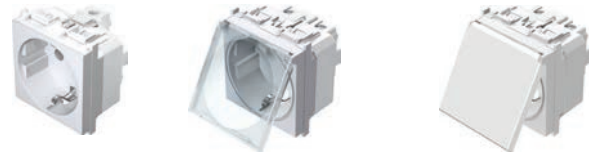

ZÁSUVKA SCHUKO+KS 2P+E 16A 250V~ 2M

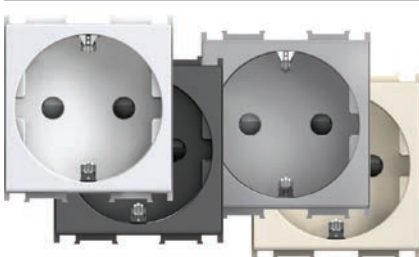

- VM10PW
- VM10SB
- VM10ES
- VM10IW

- 2P+E schuko
- 16A 250V~, typ VM10
- vyhovuje IEC 60884-1, CEE7
- skrutkové upevnenie vodičov 1,5-2,5 mm²
- KS zabudovaná detská ochrana pred dotykom kontaktov



SOCKET SCHUKO+KS 2P+E 16A 250V~ 2M

- 2P+E schuko
- 16A 250V~, type VM10
- in accordance with IEC 60884-1, CEE7
- screw contacts 1.5-2.5 mm²
- KS built-in child protection - shuttered live contacts

ZÁSUVKA SCHUKO+KS 2P+E 16A 250V~ 2M

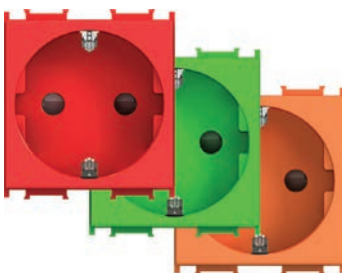

- VM10RD
- VM10GR
- VM10OR

- 2P+E schuko
- 16A 250V~, typ VM10
- vyhovuje IEC 60884-1, CEE7
- skrutkové upevnenie vodičov 1,5-2,5 mm²
- KS zabudovaná detská ochrana pred dotykom kontaktov



SOCKET SCHUKO+KS 2P+E 16A 250V~ 2M

- 2P+E schuko socket
- 16A 250V~, type VM10
- in accordance with IEC 60884-1, CEE7
- screw contacts 1.5-2.5 mm²
- KS built-in child protection - shuttered live contacts

ZÁSUVKA SCHUKO+KS+KRYT 2P+E 16A 250V~ 2M



- VM11PT
- VM11BT
- VM11ST
- VM11IT
- VM11PP

- 2P+E schuko+kryt
- 16A 250V~, typ VM11
- vyhovuje IEC 60884-1, CEE7
- skrutkové upevnenie vodičov 1,5-2,5 mm²
- KS zabudovaná detská ochrana pred dotykom kontaktov

SOCKET SCHUKO+KS+COVER

- 2P+E 16A 250V~ 2M
- 2P+E schuko+cover
- 16A 250V~, type VM11
- in accordance with IEC 60884-1, CEE7
- screw contacts 1.5-2.5 mm²
- KS built-in child protection - shuttered live contacts



S O C K E T S V M



- VM20PW
- VM20SB
- VM20ES
- VM20IW

ZÁSUVKA EURO+KS 2P 10A 250V~ 1M

- 2P Euro
- 10A 250V~, typ VM20
- vyhovuje IEC 60884-1, CEE7
- skrutkové upevnenie vodičov 1,5-2,5 mm²
- KS zabudovaná detská ochrana pred dotykom kontaktov

SOCKET EURO+KS 2P 10A 250V~ 1M

- 2P Euro
- 10A 250V~, type VM20
- in accordance with IEC 60884-1, CEE7
- screw contacts 1.5-2.5 mm²
- KS built-in child protection - shuttered live contacts

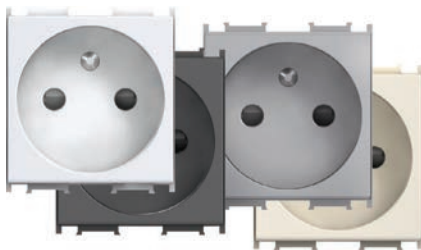

- VM40PW
- VM40SB
- VM40ES
- VM40IW

ZÁSUVKA FRANCÚZSKA+KS 2P+E 16A 250V~ 2M

- 2P+E francúzska
- 16A 250V~, typ VM40
- vyhovuje IEC 60884-1, NF C 61-314, CEE7
- skrutkové upevnenie vodičov 1,5-2,5 mm²
- KS zabudovaná detská ochrana pred dotykom kontaktov

SOCKET FRENCH+KS 2P+E 16A 250V~ 2M

- 2P+E French
- 16A 250V~, type VM40
- in accordance with IEC 60884-1, NF C 61-314, CEE7
- screw contacts 1.5-2.5 mm²
- KS built-in child protection - shuttered live contacts

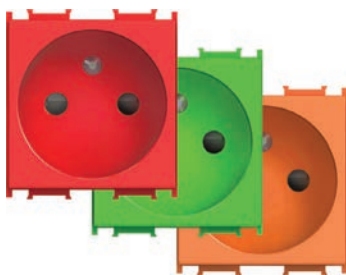

- VM40RD
- VM40GR
- VM40OR

ZÁSUVKA FRANCÚZSKA+KS 2P+E 16A 250V~ 2M

- 2P+E francúzska
- 16A 250V~, typ VM40
- vyhovuje IEC 60884-1, NF C 61-314, CEE7
- skrutkové upevnenie vodičov 1,5-2,5 mm²
- KS zabudovaná detská ochrana pred dotykom kontaktov

SOCKET FRENCH+KS 2P+E 16A 250V~ 2M

- 2P+E French
- 16A 250V~, type VM40
- in accordance with IEC 60884-1, NF C 61-314, CEE7
- screw contacts 1.5-2.5 mm²
- KS built-in child protection - shuttered live contacts

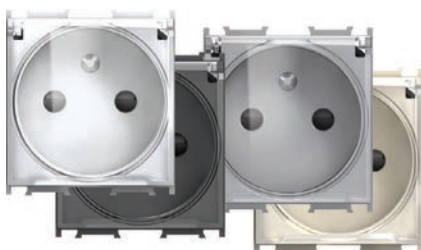
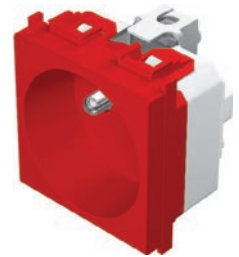

- VM41PT
- VM41BT
- VM41ST
- VM41IT

ZÁSUVKA FRANCÚZSKA + KS + KRYT 2P+E 16A 250V~ 2M

- 2P+E francúzska + kryt
- 16A 250V~, typ VM41
- vyhovuje IEC 60884-1, NF C 61-314, CEE7
- skrutkové upevnenie vodičov 1,5-2,5 mm²
- KS zabudovaná detská ochrana pred dotykom kontaktov

SOCKET FRENCH+KS+COVER

- 2P+E 16A 250V~ 2M
- 2P+E French+cover
- 16A 250V~, type VM41
- in accordance with IEC 60884-1, NF C 61-314, CEE7
- screw contacts 1.5-2.5 mm²
- KS built-in child protection - shuttered live contacts



- VM30PW
- VM30SB
- VM30ES
- VM30IW

ZÁSUVKA TALIANSKA P17/11+KS 2P+E 16A 250V~ 1M

- 2P+E talianska P17/11
- 16A 250V~, typ VM30
- vyhovuje IEC 60884-1, CEI 23-50
- skrutkové upevnenie vodičov 1,5-2,5 mm²
- KS zabudovaná detská ochrana pred dotykom kontaktov

SOCKET ITALIAN P17/11+KS 2P+E 16A 250V~ 1M

- 2P+E Italian P17/11
- 16A 250V~, type VM30
- in accordance with IEC 60884-1, CEI 23-50
- screw contacts 1.5-2.5 mm²
- KS built-in child protection - shuttered live contacts

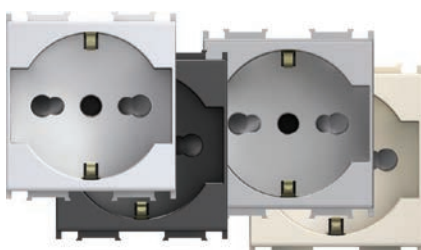

- VM31PW
- VM31SB
- VM31ES
- VM31IW

ZÁSUVKA SCHUKO/ITA P17/11+KS 2P+E 16A 250V~ 2M

- 2P+E schuko/talianska P17/11
- 16A 250V~, typ VM31
- vyhovuje IEC 60884-1, CEI 23-50
- skrutkové upevnenie vodičov 1,5-2,5 mm²
- KS zabudovaná detská ochrana pred dotykom kontaktov

SOCKET SCHUKO/ITA P17/11+KS

- 2P+E 16A 250V~ 2M
- 2P+E schuko/Italian P17/11
- 16A 250V~, type VM31
- in accordance with IEC 60884-1, CEI 23-50
- screw contacts 1.5-2.5 mm²
- KS built-in child protection - shuttered live contacts





- VM32PW
- VM32SB
- VM32ES
- VM32IW

ZÁSUVKA SCHUKO/ITA P30+KS 2P+E 16A 250V~ 2M

- 2P+E schuko/taliánska P30
- 16A 250V~, typ VM32
- vyhovuje IEC 60884-1, CEI 23-50
- skrutkové upevnenie vodičov 1,5-2,5 mm²
- KS zabudovaná detská ochrana pred dotykom kontaktov

SOCKET SCHUKO/ITA P30+KS 2P+E 16A 250V~ 2M

- 2P+E schuko/Italian P30
- 16A 250V~, type VM32
- in accordance with IEC 60884-1, CEI 23-50
- screw contacts 1.5-2.5 mm²
- KS built-in child protection - shuttered live contacts



- VM33PW
- VM33SB
- VM33ES
- VM33IW

ZÁSUVKA TALIANSKA P11+KS 2P+E 10A 250 V ~ 1M

- 2P+E talianska P11
- 10A 250 V ~, typ VM33
- vyhovuje IEC 60884-1, CEI 23-50
- skrutkové upevnenie vodičov 1,5 – 2,5 mm²
- KS zabudovaná detská ochrana pred dotykom kontaktov

SOCKET ITALIAN P11+KS 2P+E 10A 250V~ 1M

- 2P+E Italian P11
- 10A 250V~, type VM33
- in accordance with IEC 60884-1, CEI 23-50
- screw contacts 1.5-2.5 mm²
- KS built-in child protection - shuttered live contacts



- VM21PW
- VM21SB
- VM21ES
- VM21IW

ZÁSUVKA EURO/AMERICKÁ + KS 2P 16A 250V~ 1M

- 2P euro/americká
- 16A 250V~, typ VM21
- skrutkové upevnenie vodičov 1,5-2,5 mm²
- KS zabudovaná detská ochrana pred dotykom kontaktov
- len pre krajiny, ktoré nie sú členmi EÚ

SOCKET EURO/AMERICAN+KS 2P 16A 125V~ 1M

- 2P Euro/American
- 16A 250V~, type VM21
- screw contacts 1.5-2.5 mm²
- KS built-in child protection - shuttered live contacts
- only for countries not members of EU

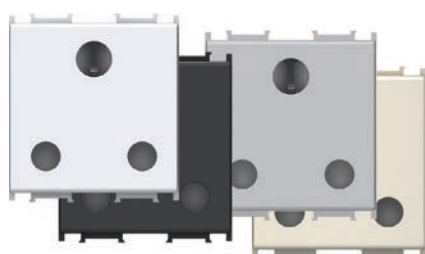

- VM51PW
- VM51SB
- VM51ES
- VM51IW

ZÁSUVKA BRITSKÁ BS 546+KS 2P+E 15A 250V~ 2M

- 2P+E britský štandard BS 546
- 15A 250V~, typ VM51
- vyhovuje BS 546
- skrutkové upevnenie vodičov 1.5-4 mm²
- zabudovaná ochrana pred dotykom kontaktov

SOCKET BRITISH BS 546+KS 2P+E 15A 250V~ 2M

- 2P+E British BS 546
- 15A 250V~, type VM51
- in accordance with BS 546
- screw contacts 1.5-4 mm²
- KS built-in child protection - shuttered live contacts

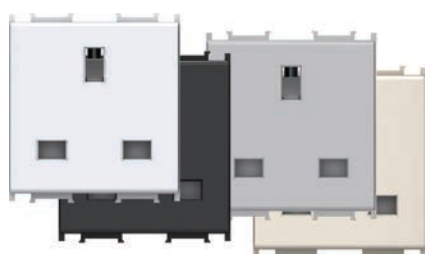

- VM52PW
- VM52SB
- VM52ES
- VM52IW

ZÁSUVKA BRITSKÁ BS 1363-2+KS 2P+E 13A 250V~ 2M

- 2P+E britský štandard BS 1363-2
- 13A/250V~, typ VM52
- vyhovuje BS 1363-2
- skrutkové upevnenie vodičov 1.5-4 mm²
- zabudovaná ochrana pred dotykom kontaktov

SOCKET BRITISH BS 1363-2+KS 2P+E 13A 250V~ 2M

- 2P+E British BS 1363-2
- 13A 250V~, type VM52
- in accordance with BS 1363-2
- screw contacts 1.5-4 mm²
- KS built-in child protection - shuttered live contacts



VM80

PREPÄŤOVÁ OCHRANA MPE MINI 275V/50Hz



- paralelné zapojenie s prvou zásuvkou v sérii
- trieda ochrany III
- U_c=275Vac, U_{oc}/I_{sc}=6kV/3kA, U_p<800V
- vyhovuje IEC 61643-1
- vodiče 1.5mm², IP20
- zvukový signál pri zničení

SURGE PROTECTOR MPE MINI 275V/50Hz

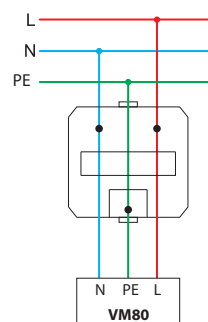

- parallel connection with the first socket in the row
- protection class III
- U_c=275Vac, U_{oc}/I_{sc}=6kV/3kA, U_p<800V
- in accordance with IEC 61643-1
- wires 1.5mm², IP20
- sound signal at breakdown

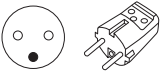
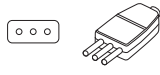

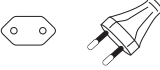
ZHODA ZÁSUVIEK A VIDLÍČ
 MATCHING SOCKETS AND PLUGS

ZÁSUVKA / SOCKET	VM10 VM11	VM20	VM30	VM33	VM31	VM32	VM40 VM41	VM21
ŠTÝL VIDLICE / PLUG STYLE								
Nemecký / German 	•				•	•		
Francúzsky / French 	•				•	•	•	
Taliánsky / Italian S11 			•	•	•	•		
Taliánsky / Italian S17 			•		•			
Euro 	•	•	•		•	•	•	•

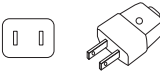
 ZHODA ZÁSUVIEK A VIDLÍČ
 MATCHING SOCKETS AND PLUGS

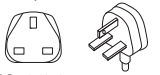
ZÁSUVKA / SOCKET	VM21	VM51	VM52
ŠTÝL VIDLICE / PLUG STYLE			
Americký / American 	•		
Britský / British BS 546 		•	
Britský / British BS 1363-2 			•

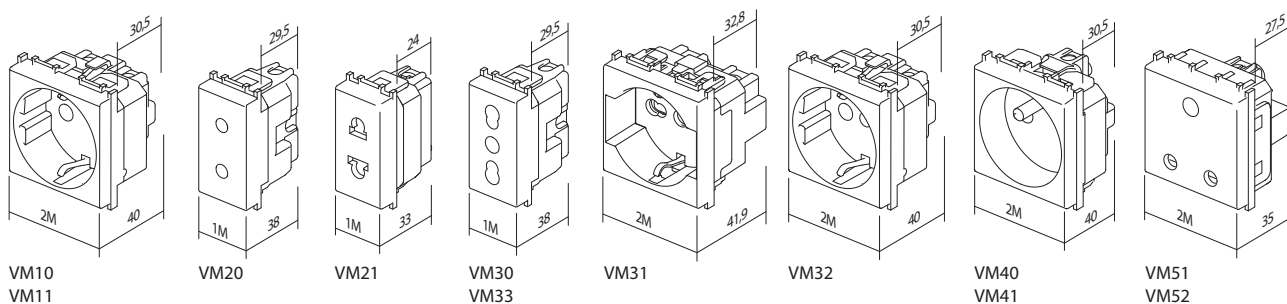
 1M = 22,5 x 45
 2M = 45 x 45
VM10
VM11

VM20

VM21

VM30
VM33

VM31

VM32

VM40
VM41VM51
VM52



KM10

PW

Typ type	názov description	technické údaje technical data	veľkosť size	farba colour
KM10	ZÁSUVKA TV ZÁKLADNÁ SOCKET TV BASIC	0dB	1M	<input type="checkbox"/> PW biely-lesklý polar white
KM11	ZÁSUVKA TV KONCOVÁ SOCKET TV END-LINE	1dB	1M	<input type="checkbox"/> SB čierna-matná soft touch black
KM12	ZÁSUVKA TV PRECHODNÁ SOCKET TV THROUGHPASS	10dB	1M	<input type="checkbox"/> ES strieborný-matný elox silver
.	.	.	.	<input type="checkbox"/> IW slonová kosť-lesklý ivory white

ZÁSUVKA TV ZÁKLADNÁ 0dB 1M



- KM10PW
- KM10SB
- KM10ES
- KM10IW

- TV základná
- útlm 0dB
- konektor vzadu – F štandard

SOCKET TV BASIC 0dB 1M

- TV basic
- reduction 0dB
- back connector – F standard



ZÁSUVKA TV ZÁKLADNÁ 0dB 2M



- KM20PW
- KM20SB
- KM20ES
- KM20IW

- TV základná
- útlm 0dB
- konektor vzadu – F štandard

SOCKET TV BASIC 0dB 2M

- TV basic
- reduction 0dB
- back connector – F standard



ZÁSUVKA TV KONCOVÁ 1dB 1M



- KM11PW
- KM11SB
- KM11ES
- KM11IW

- TV koncová
- frekvenčné pásmo 5÷2400 MHz
- útlm < 1 dB
- vyhovuje EN 50083-1
- skrutkové upevnenie

SOCKET TV END-LINE 1dB 1M

- TV end-line
- frequency range 5÷2400 MHz
- reduction < 1 dB
- in accordance with EN 50083-1
- screw contacts

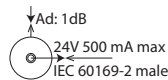

ZÁSUVKA TV PRIEBEŽNÁ 10dB 1M



- KM12PW
- KM12SB
- KM12ES
- KM12IW

- TV prechodná
- frekvenčné pásmo 5÷2400 MHz
- útlm < 10 dB
- vyhovuje EN 50083-1
- skrutkové upevnenie

SOCKET TV THROUGHPASS 10dB 1M

- TV throughpass
- frequency range 5÷2400 MHz
- reduction < 10 dB
- in accordance with EN 50083-1
- screw contacts

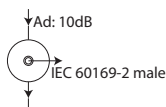

ZÁSUVKA SAT ZÁKLADNÁ 0dB 1M



- KM15PW
- KM15SB
- KM15ES
- KM15IW

- SAT základná
- útlm 0dB
- konektor vzadu – F štandard

SOCKET SAT BASIC 0dB 1M
 - SAT basic
 - reduction 0dB
 - back connector – F standard



ZÁSUVKA SAT ZÁKLADNÁ 0dB 2M

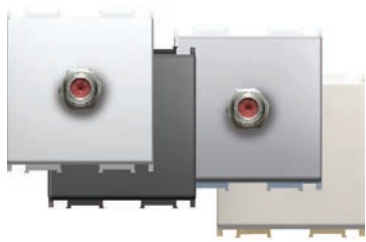

- KM24PW
- KM24SB
- KM24ES
- KM24IW

- SAT základná
- útlm 0dB
- konektor vzadu – F štandard

SOCKET SAT BASIC 0dB 2M
 - SAT basic
 - reduction 0dB
 - back connector – F standard



ZÁSUVKA SAT KONCOVÁ 1dB 1M



- KM16PW
- KM16SB
- KM16ES
- KM16IW

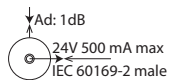

- SAT koncová
- frekvenčné pásmo 5÷2400 MHz
- útlm < 1dB
- vyhovuje EN 50083-1
- skrutkové upevnenie

SOCKET SAT END-LINE 1dB 1M
 - SAT end-line
 - frequency range 5÷2400 MHz
 - reduction < 1dB
 - in accordance with EN 50083-1
 - screw contacts



ZÁSUVKA R ZÁKLADNÁ 0dB 1M



- KM19PW
- KM19SB
- KM19ES
- KM19IW

- R základná
- útlm 0dB
- konektor vzadu – F štandard

SOCKET R BASIC 0dB 1M
 - R basic
 - reduction 0dB
 - back connector – F standard



ZÁSUVKA R ZÁKLADNÁ 0dB 2M



- KM29PW
- KM29SB
- KM29ES
- KM29IW

- R základná
- útlm 0dB
- konektor vzadu – F štandard

SOCKET R BASIC 0dB 2M
 - R basic
 - reduction 0dB
 - back connector – F standard



ZÁSUVKA SAT TV KONCOVÁ 1dB 2M



- KM25PW
- KM25SB
- KM25ES
- KM25IW

- SAT TV koncová
- frekvenčné pásmo 5÷2400 MHz
- útlm < 1dB
- vyhovuje EN 50083-1
- skrutkové upevnenie

SOCKET SAT-TV END-LINE 1dB 2M
 - SAT-TV end-line
 - frequency range 5÷2400 MHz
 - reduction < 1dB
 - in accordance with EN 50083-1
 - screw contacts

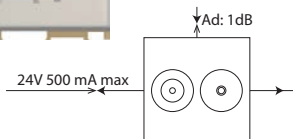

ZÁKLADNÉ SCHÉMY ZAPOJENIA
BASIC CONNECTION SAMPLES

priame zapojenie
stand alone connection

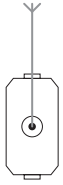

KM10
KM20
KM11
KM15
KM24
KM16
KM19
KM29
KM25

paralelné zapojenie
star connection

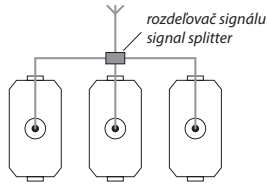

KM10
KM20
KM11
KM15
KM24
KM16
KM19
KM29
KM25

sériové zapojenie
throughpass connection

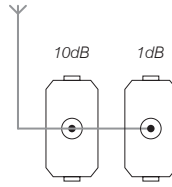

KM12 KM11

ZÁSUVKA AUDIO 2xRCA 1M



- KM22PW
- KM22SB
- KM22ES
- KM22IW

- audio 2x RCA
- upevnenie vodičov vzadu spájkovaním

SOCKET AUDIO 2xRCA 1M

- audio 2x RCA
- soldering connection of cable at the back side



ZÁSUVKA AUDIO REPRODUKTOROVÁ 1M



- KM23PW
- KM23SB
- KM23ES
- KM23IW

- audio 2x Ø4mm
- na pripojenie reproduktorového vodiča, banánovej zástrčky Ø4mm alebo vidlicovej káblovej pätky
- upevnenie vodičov vzadu spájkovaním

SOCKET AUDIO LOUDSPEAKERS 1M

- audio 2x Ø4mm
- to accommodate speaker wire, banana plug Ø4mm or spades
- soldering connection of cable at the back side



1M = 22,5 x 45
2M = 45 x 45

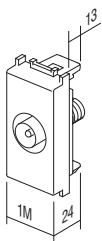

KM10

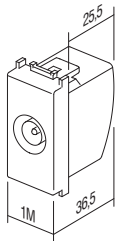

KM11
KM12

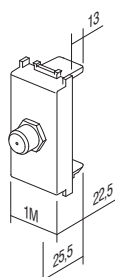

KM15

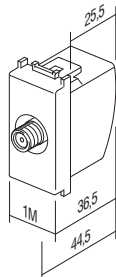

KM16

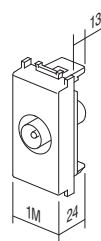

KM19

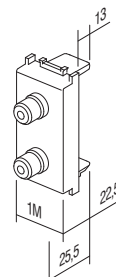

KM22
KM23

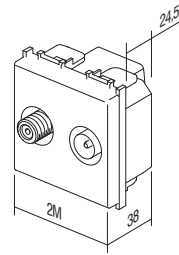

KM25

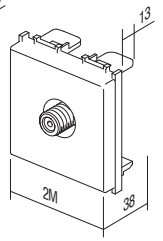

KM20
KM24
KM29

ZÁSUVKA TEL LT RJ11 6/4 1M



- KM30PW
- KM30SB
- KM30ES
- KM30IW

- TEL LT Le technika
- RJ11 6/4
- vyhovuje IEC 60603-7
- skrutkové upevnenie vodičov

SOCKET TEL LT RJ11 6/4 1M

- TEL LT Le-technika
- RJ11 6/4
- in accordance with IEC 60603-7
- screw contacts



ZÁSUVKA TEL BT SEC 6/6 1M



- KM31PW
- KM31SB
- KM31ES
- KM31IW

- TEL BT britský štandard
- SEC sekundárna 6/6
- vyhovuje BS 6312
- skrutkové upevnenie vodičov

SOCKET TEL BT SEC 6/6 1M

- TEL BT British standard
- SEC secondary 6/6
- in accordance with BS 6312
- screw contacts



ZÁSUVKA TEL KS RJ11 6/4 1M



- KM36PW
- KM36SB
- KM36ES
- KM36IW

- KS keystone štandard pripojenia
- RJ11 6/4
- vyhovuje IEC 60603-7

SOCKET TEL KS RJ11 6/4 1M

- KS keystone fixing standard
- RJ11 6/4
- in accordance with IEC 60603-7



ZÁSUVKA CAT5e KS RJ45 8/8 1M



- KM37PW
- KM37SB
- KM37ES
- KM37IW

- KS keystone štandard pripojenia
- CAT5e, RJ45 8/8
- vyhovuje IEC 60603-7

SOCKET CAT5e KS RJ45 8/8 1M

- KS keystone fixing standard
- CAT5e, RJ45 8/8
- in accordance with IEC 60603-7



ADAPTÉR KS 1M

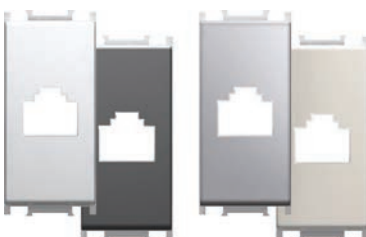

- KM35PW
- KM35SB
- KM35ES
- KM35IW

- KS keystone štandard pripojenia
- AMP, Avaya, Brandrex, FMT, Mfico, Tyco, ...
- neobsahuje komunikačný modul

ADAPTER KS 1M

- KS keystone fixing standard
- AMP, Avaya, Brandrex, FMT, Mfico, Tyco, ...
- communication module not included



ADAPTÉR KS S OCHRANOU PROTI PRACHU 1M



- KM38PW
- KM38SB
- KM38ES
- KM38IW

- KS keystone štandard upevnenia s krytom proti prachu
- AMP, Avaya, Brandrex, FMT, Mfico, Tyco, ...
- neobsahuje komunikačný modul

ADAPTER KS WITH DUST PROTECTION 1M

- KS keystone fixing standard with dust protection
- AMP, Avaya, Brandrex, FMT, Mfico, Tyco, ...
- communication module not included



ADAPTÉR KS UNIVERZÁLNY 1M



- KM50PW
- KM50SB
- KM50ES
- KM50IW

- KS keystone štandard pripojenia
- vhodný pre HDMI, USB
- neobsahuje komunikačný modul

ADAPTER KS UNIVERSAL 1M

- KS keystone fixing standard
- suitable for HDMI, USB
- communication module not included



ADAPTÉR PD 1M

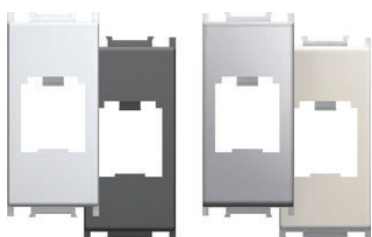

- KM40PW
- KM40SB
- KM40ES
- KM40IW

- PD Panduit Mini-COM štandard upevnenia
- neobsahuje komunikačný modul

ADAPTER PD 1M

- PD Panduit Mini-COM fixing standard
- communication module not included



ADAPTÉR PD S OCHRANOU PROTI PRACHU 1M



- KM43PW
- KM43SB
- KM43ES
- KM43IW

- PD Panduit Mini-COM štandard upevnenia
- s krytom proti prachu
- neobsahuje komunikačný modul

ADAPTER PD WITH DUST PROTECTION 1M

- PD Panduit Mini-COM fixing standard with dust protection
- communication module not included



ADAPTÉR R&M 1M



- KM46PW
- KM46SB
- KM46ES
- KM46IW

- R&M štandard upevnenia
- neobsahuje komunikačný modul

ADAPTER R&M 1M

- R&M fixing standard
- communication module not included



ADAPTÉR R&M S OCHRANOU PROTI PRACHU 1M



- KM47PW
- KM47SB
- KM47ES
- KM47IW

- R&M štandard upevnenia s krytom proti prachu
- neobsahuje komunikačný modul

ADAPTER R&M WITH DUST PROTECTION 1M

- R&M fixing standard with dust protection
- communication module not included



ADAPTÉR LK 1M



- KM45PW
- KM45SB
- KM45ES
- KM45IW

- LK LeoniKerpen eLine / BKS NewLine štandard upevnenia
- neobsahuje komunikačný modul

ADAPTER LK 1M

- LK LeoniKerpen eLine / BKS NewLine fixing standard
- communication module not included





KA26

ADAPTÉR NEXANS (N423.540N) 2M

- adaptér na upevnenie modulov Nexans LANmark veľkosti 45x45mm
- vhodný pre typ N423.540N
- neobsahuje komunikačný modul

ADAPTER NEXANS (N423.540N) 2M

- fixing adapter for Nexans LANmark module 45x45mm
- suitable for type N423.540N
- communication module not included

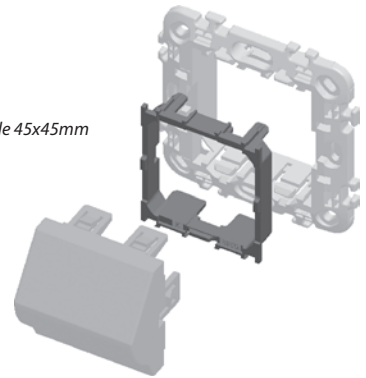

- KM48PW
- KM48SB
- KM48ES
- KM48IW

ADAPTÉR AT&T SYSTEMAX S OCHRANOU PROTI PRACHU 1M

- AT&T Systemax štandard upevnenia s krytom proti prachu
- neobsahuje komunikačný modul

ADAPTER AT&T SYSTEMAX WITH DUST PROTECTION 1M

- AT&T Systemax fixing standard with dust protection
- communication module not included



1M = 22,5 x 45
2M = 45 x 45

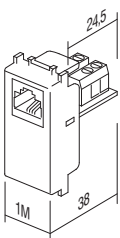

KM30

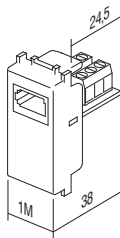

KM31

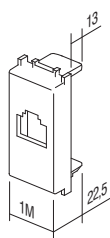

KM35
KM38
KM50
KM48

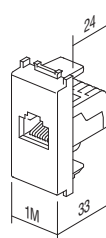

KM36
KM37

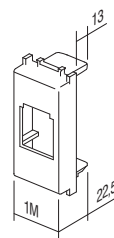

KM40
KM43

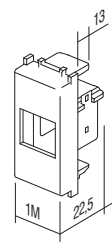

KM45

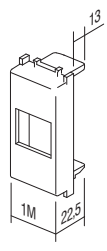

KM46
KM47
KM50



KA10

Typ type	názov description	technické údaje technical data
KA10	KONEKTOR KS CAT3 CONNECTOR KS CAT3	RJ11 6/4
KA11	KONEKTOR KS CAT5e CONNECTOR KS CAT5e	RJ45 8/8
KA12	KONEKTOR KS CAT5eS CONNECTOR KS CAT5eS	RJ45 8/8
		KONEKTOR KS CAT3 RJ11 6/4
		KA10 - KS keystone štandard pripojenia - CAT3, RJ11 6/4 - vyhovuje IEC 60603-7 CONNECTOR KS CAT3 RJ11 6/4 - KS keystone fixing standard - CAT3, RJ11 6/4 - in accordance with IEC 60603-7
		KA11 - KS keystone štandard pripojenia - CAT5e, RJ45 8/8 - vyhovuje IEC 60603-7 CONNECTOR KS CAT5e RJ45 8/8 - KS keystone fixing standard - CAT5e, RJ45 8/8 - in accordance with IEC 60603-7
		KA12 - KS keystone štandard pripojenia - CAT5eS, RJ45 8/8 - vyhovuje IEC 60603-7 CONNECTOR KS CAT5eS RJ45 8/8 - KS keystone fixing standard - CAT5eS, RJ45 8/8 - in accordance with IEC 60603-7
		KA15 - KS keystone štandard pripojenia - CAT6 UTP toolless, RJ45 8/8 - vyhovuje ISO/IEC 11801 CONNECTOR KS CAT6 SCH RJ45 8/8 - KS keystone fixing standard - CAT6 UTP toolless, RJ45 8/8 - in accordance with ISO/IEC 11801
		KA16 - KS keystone štandard pripojenia - CAT6S STP toolless, RJ45 8/8 - vyhovuje ISO/IEC 11801 CONNECTOR KS CAT6S SCH RJ45 8/8 - KS keystone fixing standard - CAT6S STP toolless, RJ45 8/8 - in accordance with ISO/IEC 11801
		KA17 - KS keystone štandard pripojenia - CAT6a STP toolless, RJ45 8/8 - vyhovuje ISO/IEC 11801 CONNECTOR KS CAT6a SCH RJ45 8/8 - KS keystone fixing standard - CAT6a STP toolless, RJ45 8/8 - in accordance with ISO/IEC 11801



KA27

KONEKTOR KS HDMI

- KS keystone štandard pripojenia
- iba v kombinácii s adaptérom KM50
- HDMI/HDMI

CONNECTOR KS HDMI

- KS keystone fixing standard
- only in combination with adapter KM50
- HDMI/HDMI



EM31



PW



Typ type	názov description	technické údaje technical data	veľkosť size	farba colour
EM10	STMIEVAČ ROTAČNÝ DIMMER ROTATIVE	R 300W	1M	<input type="checkbox"/> PW biely-lesklý polar white
EM11	STMIEVAČ ROTAČNÝ STRIEDAVÝ DIMMER ROTATIVE 2WAY	RL 300W	1M	<input type="checkbox"/> SB čierny-matný soft touch black
EM21	STMIEVAČ ZABUDOVATEĽNÝ DIMMER INBOX	RLC 300W	/	<input type="checkbox"/> ES strieborný-matný elox silver
·	·	·	·	<input type="checkbox"/> IW slonová kosť-lesklý ivory white
·	·	·	·	<input type="checkbox"/> BL modrý blue
·	·	·	·	<input type="checkbox"/> RD červený red
·	·	·	·	<input type="checkbox"/> GR zelený green
·	·	·	·	<input type="checkbox"/> OR oranžový orange
·	·	·	·	<input type="checkbox"/> RG červený/zelený red/green

STMIEVAČ ROTAČNÝ R 300W 1M



- EM10PW
- EM10SB
- EM10ES
- EM10IW

- rotačný bez spínača
- typ RTS34.43 RVP, zaťaženie R, 40W - 300W
- napájanie 230V~ 50Hz
- prepojenie so striedavým spínačom nie je možné
- prepojenie viacerých stmievačov nie je dovolené
- vyhovuje EN 60669-1
- skrutkové upevnenie vodičov 1,5-2,5 mm²
- LED indikácia

DIMMER ROTATIVE R 300W 1M

- rotation control without switch
- type RTS34.43 RVP, load R, 40W - 300W
- supply voltage 230V~ 50Hz
- 2-way switch combination is not possible
- more dimmers combination is not allowed
- in accordance with EN 60669-1
- screw contacts 1.5-2.5mm²
- LED indication



STMIEVAČ ROTAČNÝ/STRIEDAVÝ RL 300W 1M



- EM11PW
- EM11SB
- EM11ES
- EM11IW

- rotačný so striedavým spínačom
- typ RTS34 DVP, zaťaženie RL, 40W - 300W
- napájanie 230V~ 50Hz
- možné prepojenie so striedavým spínačom nie je možné
- prepojenie viacerých stmievačov nie je dovolené
- integrovaná pamäťová funkcia
- vyhovuje EN 60669-1
- skrutkové upevnenie vodičov 1,5-2,5 mm²
- LED indikácia

DIMMER ROTATIVE 2WAY RL 300W 1M

- rotation control with 2-way switch
- type RTS34 DVP, load RL, 40W - 300W
- supply voltage 230V~ 50Hz
- 2-way switch combination is possible
- more dimmers combination is not allowed
- light intensity memory
- in accordance with EN 60669-1
- screw contacts 1.5-2.5mm²
- LED indication





EM21

STMIEVAČ ZABUDOVATEĽNÝ RLC 3000W

- zabudovateľný, prepojenie so spínačom
- typ RHUN, zaťaženie RLC, 25W - 300W alebo 25VA - 250VA
- napájanie 230V~ 50Hz
- možnosť prepojenia s viacerými spínačmi
- prepojenie viacerých stmievačov nie je dovolené
- integrovaná pamäťová funkcia
- funkcia jemného zapnutia/vypnutia
- vyhovuje EN 61058-1
- vodiče 1,5mm²



DIMMER INBOX RLC 300W

- *inbox, controlled by external push button*
- *type RHUN, load RLC, 25W - 300W or 25VA - 250VA*
- *supply voltage 230V~ 50Hz*
- *several push-buttons combination is possible*
- *more dimmers combination is not allowed*
- *light intensity memory*
- *soft start / stop function*
- *in accordance with EN 61058-1*
- *wires 1.5mm²*

STMIEVAČ ZABUDOVATEĽNÝ R 500W



EM22

- zabudovateľný, prepojenie so spínačom
- typ RTL500UN, zaťaženie R, 40W - 500W
- napájanie 230V~ 50Hz
- možnosť prepojenia s viacerými spínačmi
- prepojenie viacerých stmievačov nie je dovolené
- integrovaná pamäťová funkcia
- funkcia jemného zapnutia/vypnutia
- vyhovuje EN 61058-1
- skrutkové upevnenie vodičov 1,5-2,5 mm²

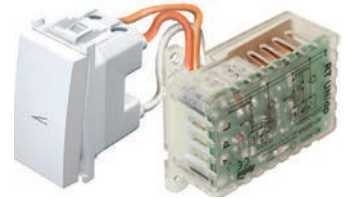

DIMMER INBOX R 500W

- *inbox, controlled by external push button*
- *type RTL500UN, load R, 40W - 500W*
- *supply voltage 230V~ 50Hz*
- *several push-buttons combination is possible*
- *more dimmers combination is not allowed*
- *light intensity memory*
- *soft start / stop function*
- *in accordance with EN 61058-1*
- *screw contacts 1.5-2.5mm²*

EM10 (40÷300W)
EM22 (40÷500W)

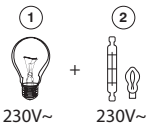

EM11 (40÷300W)

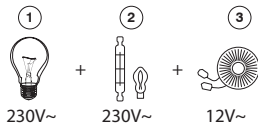

EM21 (25÷300W, 25÷250VA)

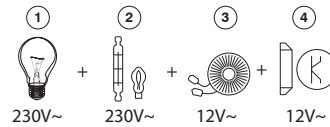

- 1 - žiarovka so žiariacim vláknom / incandescent lamp
- 2 - halogénová žiarovka / halogen lamp
- 3 - klasický transformátor / classical transformer
- 4 - elektronický transformátor / electronic transformer

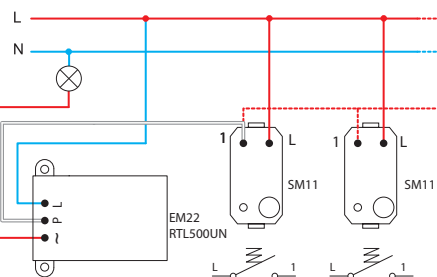
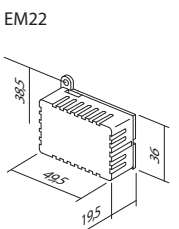
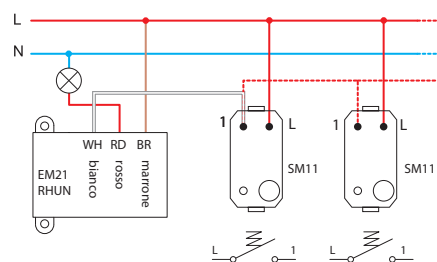
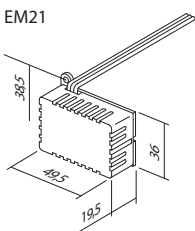
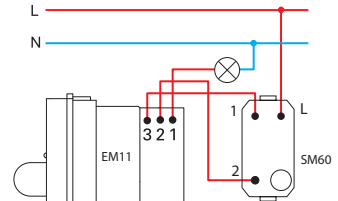
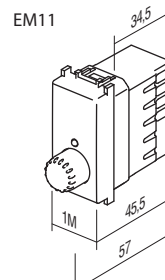
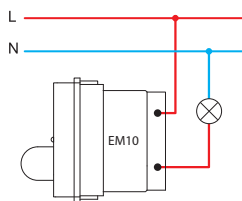
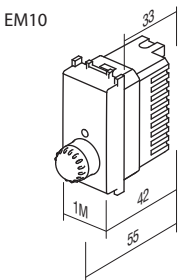

UPOZORNENIA!

V prípade montáže viacerých spínačov stmievania do tej istej krabice sa pre každý ďalší spínač zníži maximálny výkon o 10%.

ATTENTION!

If more dimmers are connected in one box reduce maximum common power for 10% for each dimmer.

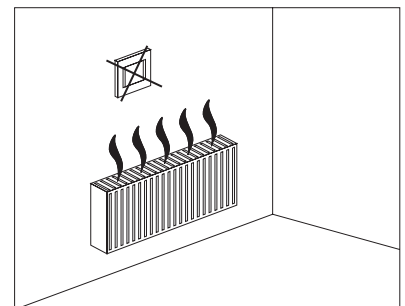

SPÍNAČ / STMIEVAČ UNIVERZÁLNY RLC 0-400W 2M

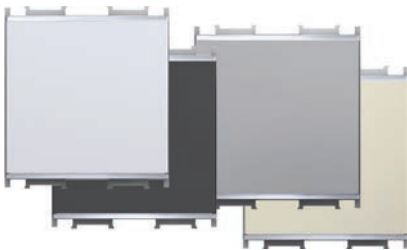

- EM25PW
- EM25SB
- EM25ES
- EM25IW



- univerzálny elektronický stmievač pre zapnutie, vypnutie a stmievanie všetkých stmievateľných žiaroviek a žiariviek (klasické, halogénové, LED, CFL, ...)
- a niektorých nestmievateľných žiariviek
- automaticky rozozná druh žiarivky a tomu prispôsobí režim činnosti
- stmievaním sa zníži spotreba elektrickej energie
- funkcia jemného zapínania predĺži životnosť žiariviek
- ovládanie prostredníctvom zabudovaných mikrospínačov
- zabudovaná pamäťová funkcia - pri vypnutí si zapamätá úroveň zatienia
- možné prepojenie až piatich (5) dodatočných ovládacích tlačidiel EM26
- prepojenie so striedavými spínačmi nie je možné
- zabudovaná ochrana pred skratom, prehrievaním a preťažením
- napájanie 230V~ 50Hz
- zabudované elegantné LED osvetlenie, s možnosťou nastavenia farby a jasú
- umožňuje výmenu klasického spínača – dvojvodičové zapojenie⁽¹⁾
- pomocou trojvodičového zapojenia dosiahneme plnú funkčnosť stmievača⁽²⁾
- vyhovuje EN 60669-1 a EN 60669-2-1
- skrutkové upevnenie vodičov 1,5 mm² (max. krútiaci moment skrutky 0,4 Nm)

TOUCH EM25 je mikroprocesorom ovládaný elektronický spínač. Umožňuje zapnutie, vypnutie a stmievanie všetkých stmievateľných a niektorých nestmievateľných žiaroviek a žiariviek. Zabudovaný mikrospínač automaticky rozozná druh žiarivky a prispôsobí tomu režim činnosti. Pri vypnutí si zapamätá posledné nastavenie, pretože má zabudovanú pamäťovú funkciu. Funkcia jemného zapínania predĺži životnosť žiariviek. V tlačidle je zabudované LED osvetlenie s možnosťou nastavenia farby a jasú. Môžeme s ním prepojiť až 5 ďalších ovládacích tlačidiel EM26 (»slave«).

TOUCH EM25 is microprocessor controlled electronic light dimmer. It serves as switch and dimmer for dimmable and some of non-dimmable lamps. Integrated microprocessor automatically identifies the type of lamp and adjusts the operating mode. It remembers the level of dimming after switching off due to integrated memory function. Soft-start function extends the lamp service life. In button integrated elegant LED illumination enables many different colours and intensity levels. Optionally one can connect of up to 5 additional control tasters EM26 ("slave").

SWITCH / DIMMER UNIVERSAL RLC 0-400W 2M

- universal electronic dimmer for ON/OFF switching and dimming of all dimmable lamps (classical, halogen, LED, CFL, ...) and some non-dimmable lamps
- automatic detection of lamp type and adjustment of operating mode
- reduction of energy consumption
- soft start function extends life of lamps
- controlled by built-in micro switches
- memory function included – memorizes brightness on turn-off
- up to five (5) additional control units EM26 can be connected
- connection with 2-way switch is not possible
- built-in short-circuit, overheating and overload protection
- supply voltage 230V~ 50Hz
- elegant LED illumination, adjustable colour and brightness
- replacement of classical switch is possible at two-wire connection⁽¹⁾
- full functionality is achieved at three-wire connection⁽²⁾
- in accordance with EN 60669-1 and EN 60669-2-1
- screw contacts 1,5mm² (max. tightening torque 0.4Nm)

⁽¹⁾ dvojvodičové zapojenie
two-wire connection

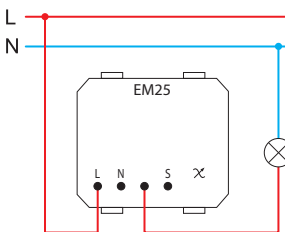

- dvojvodičové zapojenie umožňuje stmievanie stmievateľných žiaroviek a žiariviek

- two-wire connection allows dimming of dimmable lamps

⁽²⁾ trojvodičové zapojenie
three-wire connection

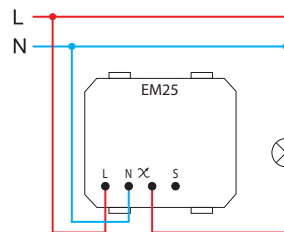

- trojvodičové zapojenie umožňuje stmievanie stmievateľných a niektorých nestmievateľných LED a CFL žiariviek

- three-wire connection allows dimming of dimmable lamps and some of non-dimmable LED and CFL lamps

	1	2	5	6	7
Min.	40 W	40 W	40 VA	40 VA	40 VA
Max.	300 W	300 W	300 VA	100 VA	100 VA
	(F)	(F)	(F)		

1 - žiarovka so žiariviacim vláknom / incandescent lamp

2 - halogénová žiarovka 220V / halogen lamp 220V

4 - elektronický transformátor / electronic transformer

5 - klasický transformátor / classical transformer

	1	2	4	6	7	8	9
Min.	0 W	0 W	0 VA	0 VA	0 VA	0 VA	0 VA
Max.	300 W	300 W	120 VA	120 VA	120 VA	120 VA	120 VA
	(F)	(F)	(F)			(F)	(F)

6 - stmievateľná úsporná CFL žiarovka / dimmable energy saving CFL lamp

7 - stmievateľná LED žiarovka / dimmable LED lamp

8 - nestmievateľná úsporná CFL žiarovka / non-dimmable energy saving CFL lamp

9 - nestmievateľná LED žiarovka / non-dimmable LED lamp

poznámky / remarks

- (F) filter EM27 / filter EM27

- odporúča sa použitie filtra EM27 / it is recommended to use filter EM27

- všetky ovládané žiarovky a žiarivky musia byť rovnaké / all controlled lamps must be the same

- tabuľka zatažení platí pre žiarivky s koeficientom PF > 0,5 / table of loads is valid for lamps with power factor PF>0.5

Zapnutie, vypnutie a stmievanie svetla /
on / off switching and dimming of lamp

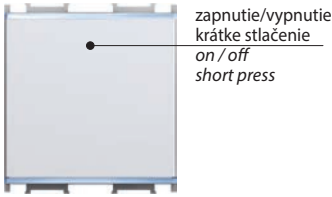

zapnutie/vypnutie
krátke stlačenie
on / off
short press

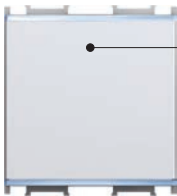

osvetľovanie
dlhšie stlačenie
dimming up
long press



stmievanie
dlhšie stlačenie
dimming down
long press

nastavenie farby a jasú LED osvetlenia /
LED colour selection and intensity level adjustment

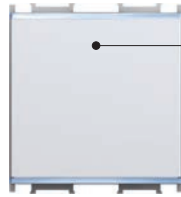

vypnutie svetla
krátke stlačenie
lamp off
short press

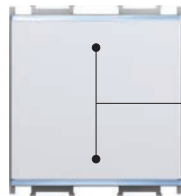

súčasné stlačenie ~ 3 s
zabudované svetlo 3x zabľká
simultaneous press ~3s
integrated LED blinks 3 times



nastavenie farby
krátke stlačenie
colour selection
short press

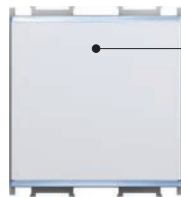

osvetlenie zabudovaného LED
svetla dlhšie stlačenie
integrated LED dimming up
long press



stmievanie zabudovaného LED
svetla dlhšie stlačenie
integrated LED dimming down
long press

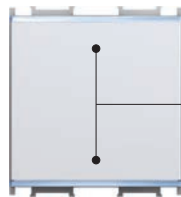

uloženie nastavení – súčasné krátke stlačenie
zabudované svetlo 3x zabľká
settings saving - simultaneous short press
integrated LED blinks 3 times

funkcia „RESET“ / “RESET” function *

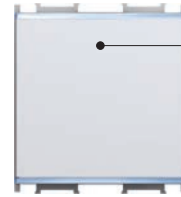

vypnutie svetla
krátke stlačenie
lamp off
short press

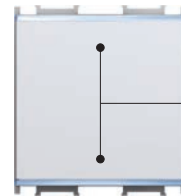

súčasné stlačenie ~ 3 s
zabudované svetlo 3x zabľká
simultaneous press ~3s
integrated LED blinks 3 times

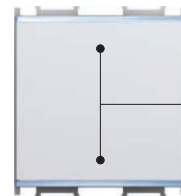

opätovné súčasné stlačenie ~ 5 s
zabudované svetlo 5x zabľká
re-simultaneous press ~5s
integrated LED blinks 5 times

- * - odporúča sa pri zabudovaní stmievača a pri výmene žiaroviek a žiariviek
- nutné pri výmene nestmievateľných žiariviek
- funkcia RESET pri použití dvojvodičového zapojenia nefunguje
- možné len pri EM25

- it is recommended at dimmer installation and lamp replacement
- mandatory when using no-dimmable lamps
- “RESET” function is not possible when using two-wire connection
- only possible on EM25

upozornenia pri inštalácii / installation precautions

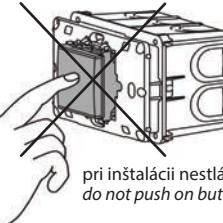
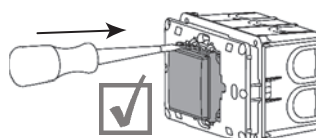
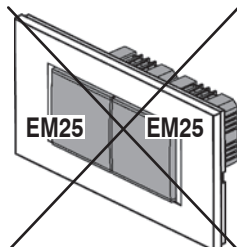
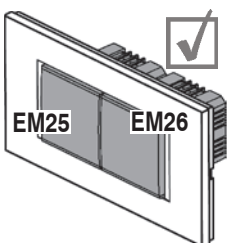

pri inštalácii nestláčajte tlačidlo /
do not push on button during mounting

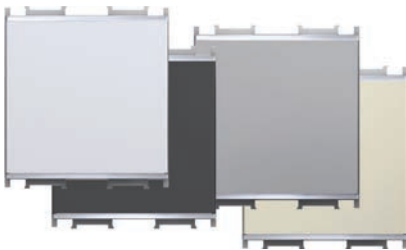

- EM26PW
- EM26SB
- EM26ES
- EM26IW

KRYTKA NA SPÍNAČ OVLÁDACIA 2M

- v spojení s univerzálnym stmievačom EM25 umožňuje ovládanie svetiel na viacerých (až piatich) miestach s rovnakou funkčnosťou ako EM25
- napájanie 230V~ 50Hz
- vyhovuje EN 60669-1 a EN 60669-2-1
- skrutkové upevnenie vodičov 1,5 mm² (max. krútiaci moment skrutky 0,4 Nm)



PUSH-BUTTON CONTROL UNIT 2M

- connected to universal dimmer EM25 allows controlling of lamps with same functionality as EM25
- supply voltage 230V~ 50Hz
- in accordance with EN 60669-1 and EN 60669-2-1
- screw contacts 1,5mm² (max. tightening torque 0,4Nm)

⁽¹⁾ dvojvodičové zapojenie
two-wire connection

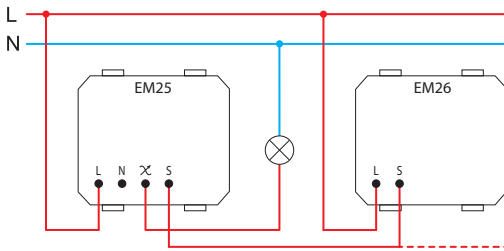

- dvojvodičové zapojenie umožňuje stmievanie stmievateľných žiaroviek a žiaroviek
- pri dvojvodičovom zapojení sa pri použití každého dodatočného ovládacieho tlačidla zvýši minimálny výkon zaťaženia o 25 W

- two-wire connection allows dimming of dimmable lamps
- in a two-wire connection each additional control unit increases the minimum load by 25W

⁽²⁾ trojvodičové zapojenie
three-wire connection

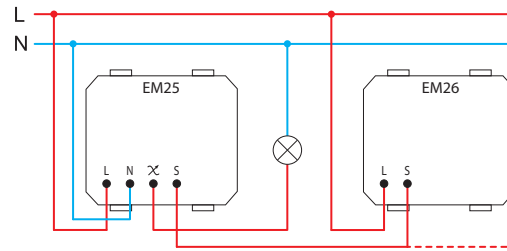

- trojvodičové zapojenie umožňuje stmievanie stmievateľných a niektorých nestmievateľných LED a CFL žiaroviek

- three-wire connection allows dimming of dimmable lamps and some of non-dimmable LED and CFL lamps

FILTER SIETOVÝCH PORÚCH



- EM27

- filter frekvenčných porúch pre EM25
- obrázok je symbolický

- FREQUENCY FILTER
- frequency filter for EM25
 - image is symbolic

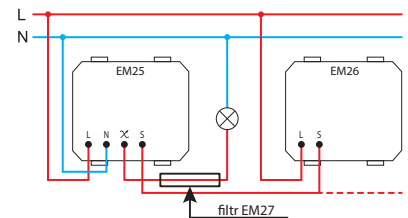

SADA SPÍNAČ/STMIEVAČ UNIVERZÁLNY RLC 0 - 300 W 2M PP OL20

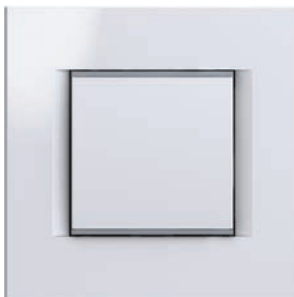

- EM25PPOL20

- sada obsahuje stmievač, montážny rámik 2M a rámk LINE 2M PW
- pre technické údaje pozri EM25

SET SWITCH / DIMMER UNIVERSAL RLC
0-300W 2M PP OL20

- set includes dimmer EM25, mounting frame 2M and cover plate LINE 2M PW
- for technical details see EM25



2M = 45 x 45

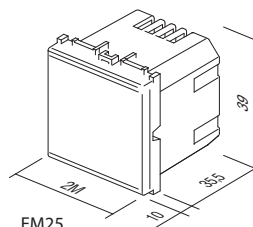

EM25
EM26



- EM31PW
- EM31SB
- EM31ES
- EM31IW

IR SPÍNAČ 5A 250 V ~ 1M

- IR infračervený spínač
- napájanie: 230 V ~ ± 10 % 50 Hz
- relé: 5 A/250 V ~ výstupný prúd je obmedzený vysokou odolnosťou na prechod nulou
- stupeň zabezpečenia: IP40
- prierez vodičov v mieste pripojenia: 0,75 – 2,5 mm²
- detekčný uhol: do 110° pri 20 °C
- detekčná oblasť: približne 8 m pri 20 °C
- nastavitelnosť času trvania: od cca 5 s do 12 min.
- nastavitelnosť osvetlenia: od cca 5 do 200 LUX
- prevádzková teplota: od 0 °C do +40 °C
- nie je vhodný na zabudovanie do krabíc s hĺbkou 45 mm a povrchových montážnych krabíc GUBO IP20
- iba na interiérové použitie



detekčná oblasť / detection range

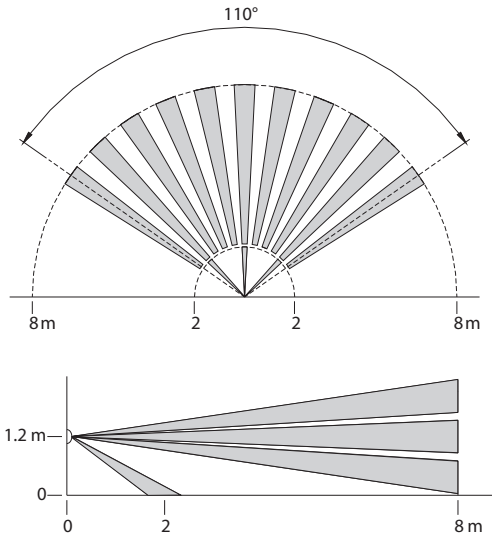

IR SWITCH 5A 250V~ 1M

- IR infrared switch
- supply voltage: 230V~ ±10 % 50Hz
- relay: 5A / 250V~ output for limited current with high resistance for zero crossing
- protection rating: IP40
- cross-section of wires at the contact terminal: 0.75 - 2.5 mm²
- detection angle: up to 110° at 20°C
- detection area: approx. 8 m at 20°C
- adjustability of duration: from approx. 5 s to 12 min
- adjustability of brightness: from approx. 5 to 200 LUX
- operating temperature: from 0°C to +40°C
- not suitable for installation in 45 mm deep boxes and surface mount box CUBO IP20
- only for indoor usage

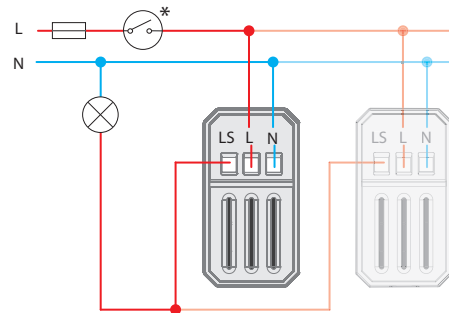

nastavenie citlivosti a času osvetlenia / time and twilight adjustment

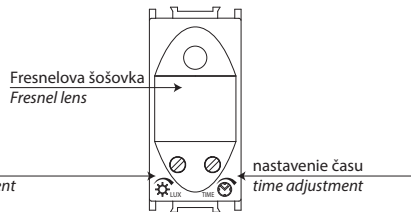

nastavenie citlivosti svetla
twilight sensor threshold adjustment

nastavenie času
time adjustment

5 LUX	~5 s	200 LUX	~12 min

zariadenia / loads

	1	2	3	4	5	6	7	8
Min.	1 W	1 W		1 VA	1 W	1 W	1 VA	1 VA
Max.	800 W	800 W	5 A	6x20 VA	6x36 W	4x36 W (20µF)	6x23 VA	6x20 VA

1 - žiarovka so žiariacim vláknom / incandescent lamp

2 - halogénová žiarovka 220 V / halogen lamp

3 - odporové vykurovacie teleso / resistive heating element

4 - elektronický transformátor / electronic transformer

5 - fluorescenčná trubica (prevedenie 1) / fluorescent tube (version 1)

6 - fluorescenčná trubica (prevedenie 2) / fluorescent tube (version 2)

7 - úsporná CFL žiarivka / energy saving CFL lamp

8 - LED žiarivka / LED lamp

upozornenia / attention

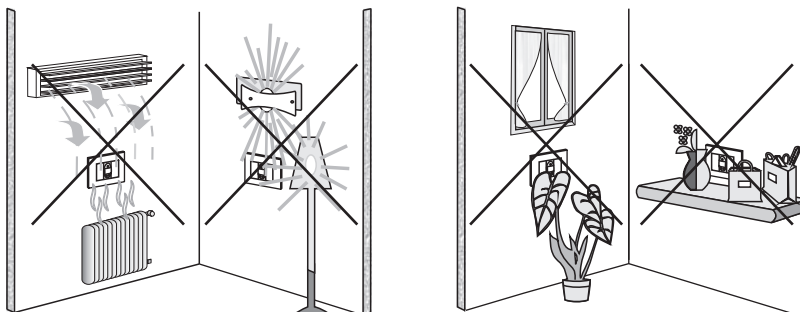

1M = 22,5 x 45

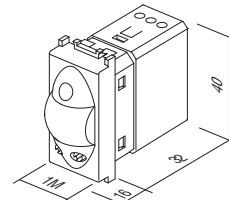

TERMOSTAT ZÁKLADNÝ 6 A 230 V ~ 2M



- EM37PW
- EM37SB
- EM37ES
- EM37IW



Termostat je určený na reguláciu teploty v priestore. Umožňuje dva režimy prevádzky – vyhrievanie a chladenie. Má zabudované ochranné funkcie proti zamrznutiu (režim vyhrievania) a proti prehrievaniu (režim chladenia). Činnosť termostatu je signalizovaná pomocou LED svetiel. Nastavenie termostatu sa vykonáva pomocou otočného gombíka na nastavenie teploty a kapacitných dotykových tlačidiel.

The thermostat is intended for regulating temperature in a room. A thermostat enables two modes of operation – heating and cooling. It has safety functions installed for protection against freezing (heating mode) and protection against overheating (cooling mode). The operation is indicated via LED lights. Thermostat setup is performed with the help of a rotary button for setting the temperature and with other capacitive touch buttons.

- termostat elektronický, základný
- režim činnosti: vyhrievanie/chladenie/vypnutie
- napájanie: 230 V striedavé napätie, 50 Hz
- výstup: 6(2) A, 230 V striedavé napätie, prepínacie relé
- pásmo regulácie: +10 °C do +30 °C
- hysterezia: ±0,5 °C
- ochrana proti zamrznutiu (režim vyhrievania): +6 °C
- ochrana proti prehrievaniu (režim chladenia): +32 °C
- funkcia ECO na zníženie teploty o 3 °C za 6 hodín v režime chladenie
- funkcia adaptívny ECO každý deň v rovnakom čase automaticky zníži teplotu o 3 °C za 6 hodín v režime vyhrievania a zvýši teplotu o 3 °C za 6 hodín v režime chladenia
- možnosť zapnutia ECO režimu prevádzky s vonkajším spustením pomocou samostatného vstupu
- LED indikácia činnosti
- nie je vhodný pre podlahové kúrenie
- skrutkové upevnenie vodičov max. 2,5 mm²
- vyhovuje direktíve LV, direktíve EMC, normám EN60730-1 a EN60730-2-9
- pre správnu činnosť sa odporúča zabudovanie do samostatnej krabice, oddelene od tepla generujúcich zariadení
- prevádzková teplota: 5 ÷ 35 °C
- teplota skladovania: -20 ÷ 50 °C

THERMOSTAT BASIC 6A 230 V ~ 2M

- electronic thermostat, basic
- operation mode: heating/cooling/turn off
- power supply: 230 VAC, 50 Hz
- output: 6(2) A, 230 VAC, relay switch
- regulation range: +10°C to +30°C
- hysteresis: ±0.5°C
- anti-freeze protection (heating mode): +6°C
- overheating protection (cooling mode): +32°C
- ECO function for lowering the temperature by 3°C for 6 hours in the heating mode and raising temperature by 3°C for 6 hours in the cooling mode
- adaptive ECO function, automatically every day at the same time lowers the temperature by 3°C for 6 hours in the heating mode and raises temperature by 3°C for 6 hours in the cooling mode
- option to turn on the ECO operating mode by external trigger via a separate input
- LED indication of operation
- not suitable for electrical floor heating
- screw contacts max. 2.5 mm²
- in accordance with the LV Directive, the EMC Directive, standards EN60730-1 and EN60730-2-9
- for correct operation, we recommend installing in an independent single box, separate from devices that generate heat
- operating temperature: 5 ÷ 35°C
- storage temperature: -20 ÷ 50°C

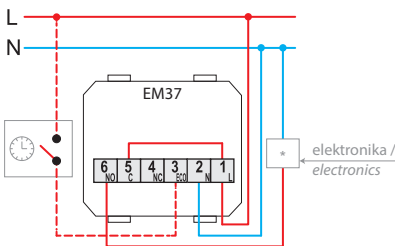

obehové čerpadlo, horák (priame pripojenie),
termoelektrický pohon /
circulation pump, burner (direct connection)
thermoelectric drive

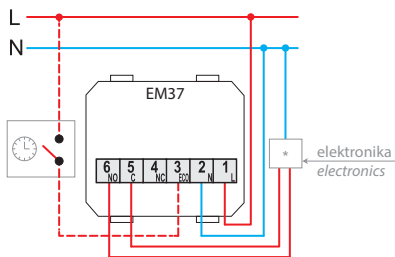

Kotol, tepelné čerpadlo, horák (riadiaci vstup T1/T2) /
boiler, heat pump, burner (control input T1/T2)

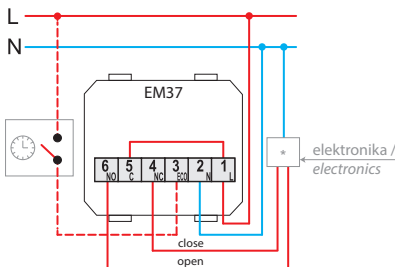

motorový pohon (obmedzené použitie pri podlahovom kúrení) /
motor drive (limited use with underfloor heating)

nastavenie činnosti a teploty / function and temperature adjustment

tlačidlo pre nastavenie činnosti a
LED indikátor stavu:
červená: vyhrievanie
modrá: chladenie
nesvieti: vypnuté

function selection button and
LED status indicator:
red: heating
blue: air conditioning
no light: switched off

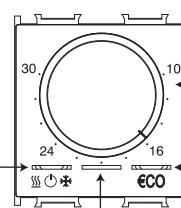

nastavenie teploty
temperature setting

tlačidlo pre výber „ECO“ režimu
LED indikátor „ECO“ režimu
zelená: ECO režim zapnutý
oranžová: adaptívny ECO aktivovaný
nesvieti: denný režim

“ECO” function selection button and
LED “ECO” status indicator
green: ECO energy saving ON
orange: adaptive ECO mode activated
no light: day mode

LED wskaźnik stanu przekaźnika wyjścia
biały: przekaźnik włączony
nie świeci: przekaźnik wyłączony

LED output relay state indicator
white: relay ON
no light: relay OFF

upozornenia / attention

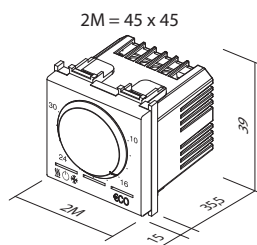
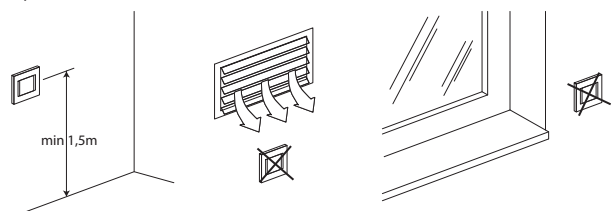



- EM40PW
- EM40SB
- EM40ES
- EM40IW

KARTOVÝ SPÍNAČ NA ŠETRENIE ELEKTRICKEJ ENERGIE 3A 250V~ 3M

- kartový spínač základný, ľubovoľná ISO karta
- napájanie 230V~ 50Hz
- výstup 3A 250V~ na zapnutie vonkajšieho stykača*
- omeškanie vypnutia 15-20s
- vyhovuje EN 61000-6-1
- karta nie je priložená
- nie je určený na kontrolu prístupu



ENERGY SAVER BADGE SWITCH 3A 250V~ 3M

- badge switch basic, any ISO card
- supply voltage 230V~ 50Hz
- output 3A 250V~ for switching contactor*
- switch off delay 15-20s
- in accordance with EN 61000-6-1
- card is not included
- not for access control

3M = 67,5 x 45

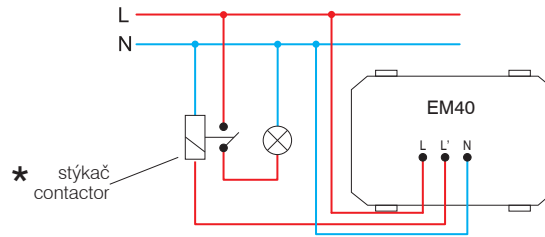
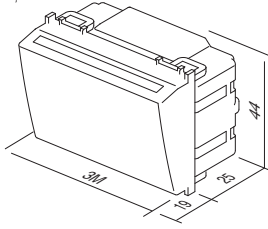

* stýkač
contactor

KARTOVÝ SPÍNAČ NA ŠETRENIE ELEKTRICKEJ ENERGIE ČIAROVÝ KÓD 3M



- EM41PW
- EM41SB
- EM41ES
- EM41IW

- kartový spínač elektronický na ISO kartu s čiarovým kódom EM47
- napájanie 5V od relé jednotky EM48
- výstup na spojenie s jednou relé jednotkou EM48
- omeškanie vypnutia 15-20s
- vyhovuje EN 61000-6-1
- karta EM47 nie je priložená
- nie je určený na kontrolu prístupu



ENERGY SAVER BADGE SWITCH BAR CODE 3M

- badge electronic switch for ISO card with BAR code EM47
- supply 5V from relay unit EM48
- output to be connected to relay output unit EM48
- switch off delay 15-20s
- in accordance with EN 61000-6-1
- card EM47 is not included
- not for access control

KARTOVÝ SPÍNAČ NA ŠETRENIE ELEKTRICKEJ ENERGIE RF HF 13,56MHz 3M



- EM43PW
- EM43SB
- EM43ES
- EM43IW

- kartový spínač elektronický na RFID ISO kartu
- RF HF nosná frekvencia 13,56 MHz
- napájanie 5V od relé jednotky EM48
- výstup na spojenie s jednou relé jednotkou EM48
- omeškanie vypnutia 15-20s
- vyhovuje EN 61000-6-1
- RFID karta nie je priložená
- nie je určený na kontrolu prístupu



ENERGY SAVER BADGE SWITCH RF HF 13,56MHz 3M

- badge electronic switch for RFID ISO card
- RF HF carrier frequency 13,56MHz
- supply 5V from relay unit EM48
- output to be connected to relay output unit EM48
- switch off delay 15-20s
- in accordance with EN 61000-6-1
- RFID card is not included
- not for access control

KARTA ISO ČIAROVÝ KÓD

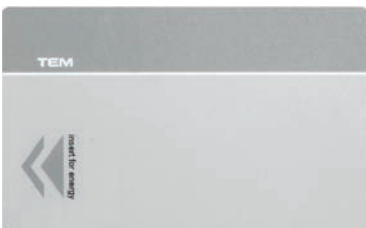

EM47

- ISO karta s čiarovým kódom
- na použitie s kartovým spínačom EM41
- veľkosť: 85x54 mm

BADGE ISO BAR CODE

- ISO card with bar code
- for combination with badge switch EM41
- size: 85x54 mm



EM48

RELÉ JEDNOTKA NA KARTOVÝ SPÍNAČ 2x16A 250V~

- relé jednotka na kartové spínače EM41, EM43
- napájanie 230V~ 50Hz
- výstupné relé L1 16A 250V~ základné napájanie
- výstupné relé L2 16A 250V~ HVAC napájanie
- M1, M2 vstup pre magnetický spínač na vypnutie HVAC pri otvorení okna alebo balkónových dverách
- vyhovuje EN 61000-6-1
- montáž na DIN lištu 35mm, 4MU



ENERGY SAVER CONTROL UNIT 2x16A 250V~

- relay unit for badge switches EM41, EM43
- supply voltage 230V~ 50Hz
- output relay L1 16A 250V~ main supply
- output relay L2 16A 250V~ HVAC supply
- M1, M2 input for magnetic switch to control HVAC when window or balcony door are opened
- in accordance with EN 61000-6-1
- mounting on DIN rail 35mm, 4MU

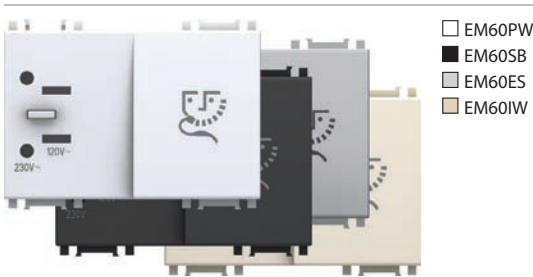
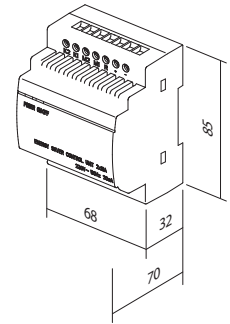
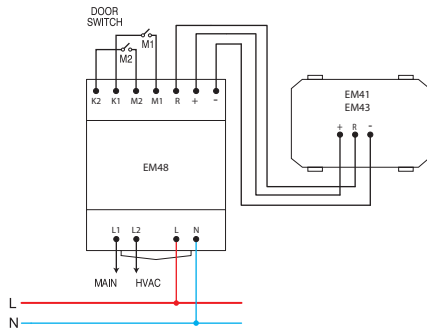

- EM60PW
- EM60SB
- EM60ES
- EM60IW

ZÁSUVKA NA HOLIACI STROJČEK 230V~/125V~ 3M

- zásuvka na holiaci strojček s izolačným transformátorom 20VA
- vstup: 230V~ 50-60Hz
- výstup: 230V~ pre 2P 2,5A EURO zástrčku alebo 125V~ pre 2P 15A americkú zástrčku
- trieda ochrany II
- vyhovuje EN 61558-2-5



SOCKET SHAVER 230V~/125V~ 3M

- shaver supply unit with isolating transformer 20VA
- supply: 230V~ 50-60Hz
- output: 230V~ for 2P 2.5A Europlug or 125V~ for 2P 15A American plug
- Class II
- in accordance with EN 61558-2-5

3M = 67,5 x 45

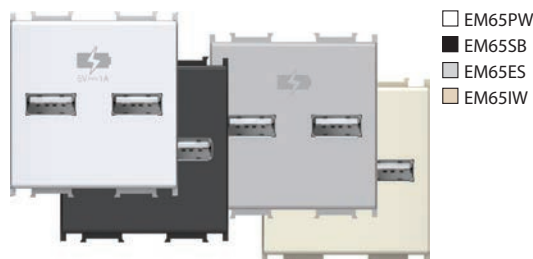
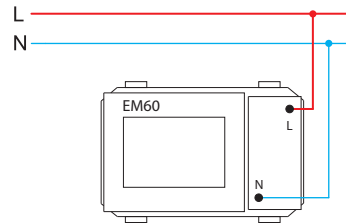
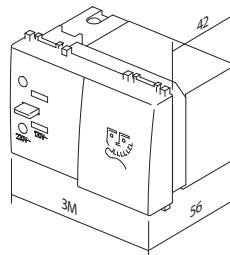

- EM65PW
- EM65SB
- EM65ES
- EM65IW

NABÍJAČKA USB 5V 1A 2M

- pre nabíjanie elektronických zariadení pomocou štandardného USB pripojenia (kompatibilné aj so zariadeniami Apple)
- umožňuje súčasné nabíjanie dvoch zariadení
- napájanie: 230 V ~ 50 Hz
- spotreba v pokoji: 50 mW pri 230 V ~
- výstupné napätie: 5 V jednosmerné napätie (± 5 %) SELV
- kolísanie výstupného napätia: 150 mV
- menovitý výstupný prúd: 1 A (1 x 1.000 mA alebo 2 x 500 mA) (±10 %)
- efektívnosť: viac ako 67 %
- IP ochranná trieda: IP20, len na vnútorné použitie
- skrutkové upevnenie vodičov max. 2,5 mm²
- vyhovuje normám EN 60950-1 a direktive EMC
- nabíjačka musí byť chránená vhodným vonkajším ističom



2M = 45 x 45

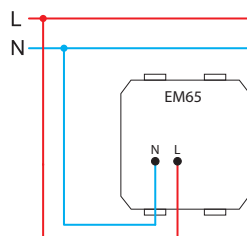
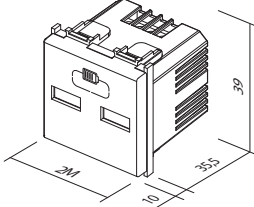

POWER SUPPLY UNIT USB 5V 1A 2M

- for charging of electronic devices via a standard USB port (also compatible with Apple devices)
- enables charging of two devices simultaneously
- power supply: 230V~ 50Hz
- stand-by power consumption: 50 mW at 230V~
- nominal output voltage: 5 VDC (± 5%) SELV
- output ripple voltage: 150 mV
- nominal output current: 1 A (1 x 1.000 mA or 2 x 500 mA) (±10%)
- efficiency: greater than 67%
- IP protection class: IP20, indoor use only
- screw contacts: max. 2.5 mm²
- in accordance with EN 60950-1 and EMC directive
- an appropriate external disconnect device needs to be considered as part of installation



EM55

LED NÚDZOVÉ SVIETIDLO 250V~ 1.5W, NiMh 6h 7M

- núdzové LED svietidlo
- napájanie 230V~ 50Hz 3x0.5W LED žiarivky E10, vymeniteľné
- NiMh akumulátor 1150 mAh, vymeniteľný
- autonómia 6h, nabíjanie 4h
- trieda ochrany II
- vyhovuje EN 60598-1, EN 60598-2-2, EN 60598-2-22
- svietivosť 76lx / 0,9m²



LED EMERGENCY LIGHT 250V~ 1.5W, Ni-Mh 6h 7M

- emergency LED lamp
- supply voltage 230V~ 50Hz 3x0.5W LED lamps E10, replaceable
- NiMh accumulator 1150 mAh, replaceable
- autonomy 6h, charging 4h
- Class II
- in accordance with EN 60598-1, EN 60598-2-2, EN 60598-2-22
- illumination 76lx / 0,9m²

7M = 151,5 x 45

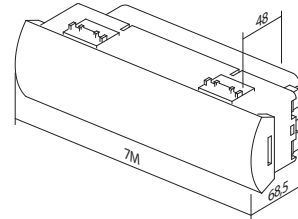
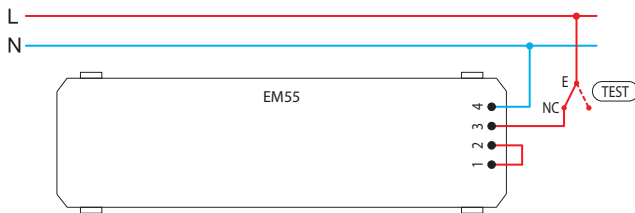

SVIETIDLO LED JEDNOFARBENÉ 250V~ 0,8W 2M

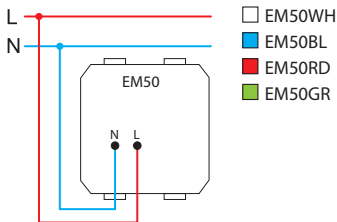

EM50WH
EM50BL
EM50RD
EM50GR

- LED svietidlo na osvetlenie schodísk alebo chodieb
- napájanie 230V~ 50Hz 0,8W
- trieda ochrany II
- vyhovuje EN 60598-1
- využitie aj pre orientačné alebo signalizačné osvetlenie s možnosťou laserovej tlačie ľubovoľného symbolu

LED LAMP MONOCOLOUR 250V~ 0,8W 2M

- step marker LED lamp
- supply voltage 230V~ 50Hz 0,8W
- Class II
- in accordance with EN 60598-1
- optional usage for directional or signal illumination with customized laser printing on diffuser



SVIETIDLO LED DVOJFARBENÉ 250V~ 2x0,4W 2M

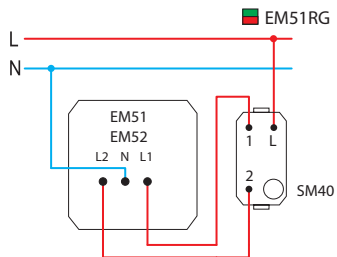

EM51RG

- LED dvojfarebné osvetlenie (červená/zelená) na signalizáciu
- napájanie 230V~ 50Hz 2x0,4W
- trieda ochrany II
- vyhovuje EN 60598-1
- obsahuje symboly ako na obrázku
- možnosť laserovej tlačie ľubovoľného symbolu

LED LAMP DUAL COLOUR 250V~ 2x0,4W 2M

- signalling dual colour (red/green) LED lamp
- supply voltage 230V~ 50Hz 2x0,4W
- Class II
- in accordance with EN 60598-1
- diffuser includes graphics as shown
- possible customized laser printing on diffuser

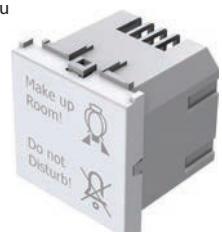

LED LAMPA 3D DVOJFARBENÁ 250V~ 2x0,4W 2M

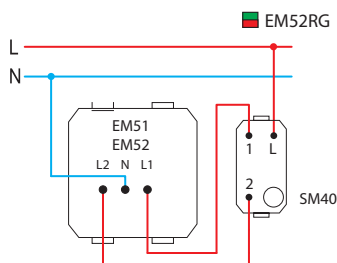

EM52RG

- dvojfarebná lampka LED (červená-zelená) s 3D znakom, na signalizáciu
- napájanie 230V~ 50Hz 2x0,4W
- ochranná trieda II
- vyhovuje EN 60598-1
- možnosť vytlačenia rôznych grafík na objednávku

LED LAMP 3D DUAL COLOUR 250V~ 2x0,4W 2M

- signalling LED lamp, dual colour (red/green) with 3D symbol
- supply voltage 230V~ 50Hz 2x0,4W
- class II
- in accordance with EN 60598-1
- possible customized graphics on request



2M = 45 x 45

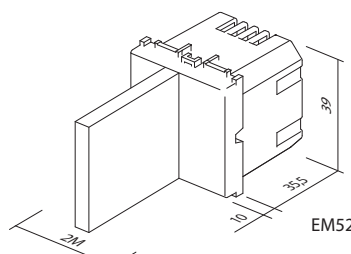
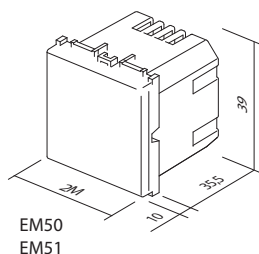



- EM70PW
- EM70SB
- EM70ES
- EM70IW

SPÍNAČ NA ODTLAČKY PRSTOV ARX ONE 2M

- spínač na odtlačky prstov v kombinácii s vnútornou relé jednotkou
- na odomykanie elektrických zámokov
- kapacita 1000 odtlačkov
- jednoduché programovanie pomocou dvoch tlačidiel
- termický biometrický senzor
- napájanie vnútornej relé jednotky 110-230V~ 50-60Hz
- výstupné relé 2x3A 12V DC
- 256-bitové šifrovanie spojenia medzi spínačom a vnútornou relé jednotkou
- vyhovuje EN 61000-6-1



FINGERPRINT SWITCH ARX ONE 2M

- fingerprint switch with included internal relay unit
- for unlocking electrical locks
- capacity 1000 fingerprints
- easy programming with two buttons
- thermal biometric sensor
- internal relay unit supply 110-230V~ 50-60Hz
- output relay 2x3A 12V DC
- 256-bit encrypted link between switch and internal relay unit
- in accordance with EN 61000-6-1

ZADANIE SPRÁVCU

1. Prvé tri odtlačky majú správcovské práva.
2. Postup zadania je rovnaký ako pri pridávaní používateľa, avšak s vynechaním druhého kroku.

ADMINISTRATOR ENROLMENT

1. The first three fingerprints enrolled are assigned administrative rights.
2. Administrator enrolment procedure is same as user enrolment without second step.

PRIDANIE POUŽÍVATEĽA

1. Na vonkajšej jednotke 3 sekundy držíme ľavé tlačidlo. Oranžová dióda začne pomaly blikať.
2. Správca prstom raz prejde cez senzor. Oranžová dióda začne rýchlo blikať.
3. Stlačíme ľavé tlačidlo. Pre potvrdenie sa rozsvieti zelená dióda a zvukový signál v dĺžke 1 s.
4. Oranžová a zelená dióda striedavo blikajú. Teraz prstom cez senzor štyrikrát prejde používateľ. Každé zadanie sprevádza zvukový signál.
5. Keď je odtlačok používateľa úspešne zadaný, zasvieti zelená dióda a ozve sa zvukový signál.

USER ENROLMENT

1. The left button on the exterior unit is pressed for 3 seconds. The orange LED starts flashing slow.
2. An administrator swipes his finger over the sensor once. When he/she is identified, the orange LED will start flashing fast.
3. Press left button. The green LED confirms.
4. The orange and green LED will flash alternately. At this point the user swipes his/her finger over the sensor four times. Each successful entry is indicated by a buzz.
5. When the user is correctly enrolled, the green LED will flash and the buzzer will buzz at the same time.

VYMAZANIE POUŽÍVATEĽA

1. Na vonkajšej jednotke 5 sekúnd držíme pravé tlačidlo. Oranžová dióda začne pomaly blikať.
2. Správca prstom raz prejde cez senzor. Úspešná identifikácia je potvrdená, keď zasvieti zelená dióda a ozve sa zvukový signál.
3. Červená a zelená dióda striedavo blikajú. Po senzore raz prejde prstom používateľ, ktorého chceme vymazať. Keď je pozitívne identifikovaný, rozsvieti sa zelená dióda a ozve sa zvukový signál 1 s. Používateľ je úspešne vymazaný.

DELETING A USER

1. The right button on the exterior unit should be pressed for 5 seconds whereupon the orange LED will start flashing slow.
2. An administrator swipes his finger over the sensor once. When he/she is identified, the green LED will flash and the buzzer will buzz at the same time.
3. The red and green LED will flash alternately. Then the user swipes his finger over the sensor once. When the user is identified, the green LED flash and the buzzer will buzz once. The user has been successfully deleted from the system.

VYMAZANIE VŠETKÝCH ODTLAČKOV

1. Na vonkajšej jednotke držíme 10 sekúnd obidve tlačidlá. Oranžová a červená dióda začnú striedavo blikať.
2. Správca prstom raz prejde cez senzor. Úspešná identifikácia je potvrdená, keď zasvieti zelená dióda a ozve sa zvukový signál.
3. Oranžová a červená dióda znova striedavo blikajú. Správca zopakuje 2. krok.
4. Po krátkej prestávke zasvieti červená a oranžová dióda celkovo päťkrát a na zariadení sa päťkrát ozve zvukový signál v rovnakom intervale. Všetky odtlačky boli úspešne vymazané z databázy.

DELETING ALL FINGERPRINTS

1. Press the left and right button on the exterior unit together for a period of 10 seconds whereupon the orange and red LED will flash alternately.
2. The administrator then swipes his/her finger once. Identification is confirmed when the green LED flashes and the buzzer buzzes at the same time.
3. The orange and red LED will flash alternately again. The administrator repeats second step.
4. The red and orange LED will flash and the buzzer will buzz five times simultaneously. All fingerprint templates will then have been deleted.

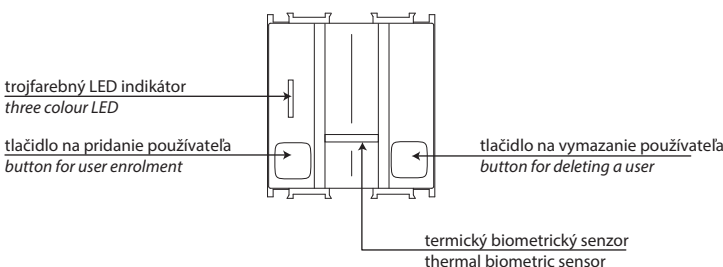
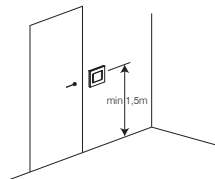

externá jednotka
exterior unit

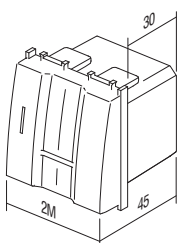

interná relé jednotka
interior relay unit

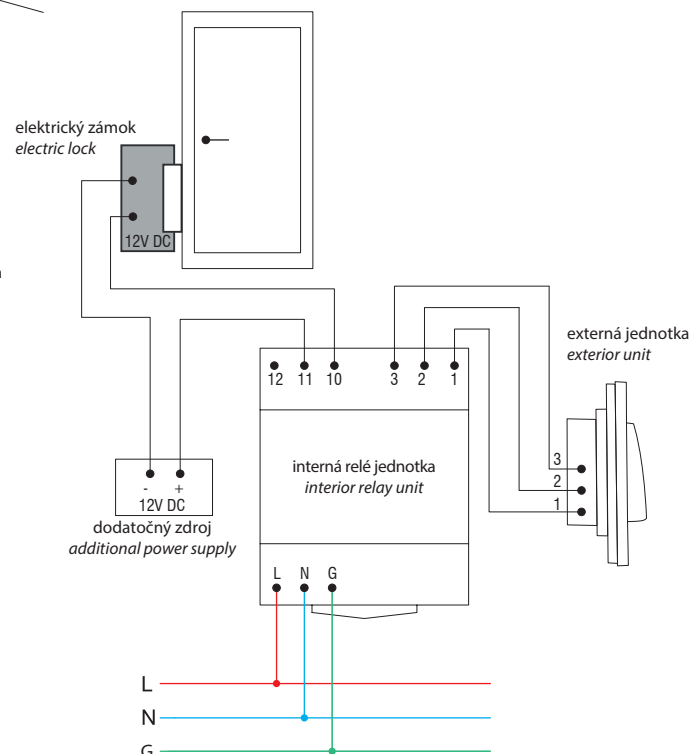
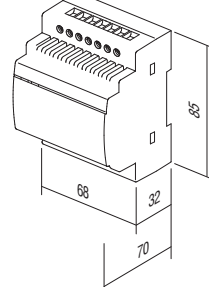

BZUČIAK 8VA 230V~ 1M



- EM90PW
- EM90SB
- EM90ES
- EM90IW

- signálny bzučiak
 - dĺžka zvukového signálu je rovnaká ako dĺžka stlačenia tlačidla
 - napájanie 230V~ 50Hz 8VA

BUZZER 8VA 230V~1M

- signal buzzer
 - the sound emission has the same lasting time as the control operation
 - supply voltage 230V~ 50Hz 8VA



BZUČIAK 8VA 12V~ 1M



- EM91PW
- EM91SB
- EM91ES
- EM91IW

- signálny bzučiak
 - dĺžka zvukového signálu je rovnaká ako dĺžka stlačenia tlačidla
 - napájanie 12V~ 50Hz 8VA

BUZZER 8VA 12V~1M

- signal buzzer
 - the sound emission has the same lasting time as the control operation
 - supply voltage 12V~ 50Hz 8VA



ZVONČEK 8VA 230V~ 1M



- EM92PW
- EM92SB
- EM92ES
- EM92IW

- signálny zvonček
 - dĺžka zvukového signálu je rovnaká ako dĺžka stlačenia tlačidla
 - napájanie 230V~ 50Hz 8VA

BELL 8VA 230V~1M

- signal bell
 - the sound emission has the same lasting time as the control operation
 - supply voltage 230V~ 50Hz 8VA



ZVONČEK 8VA 12V~ 1M



- EM93PW
- EM93SB
- EM93ES
- EM93IW

- signálny zvonček
 - dĺžka zvukového signálu je rovnaká ako dĺžka stlačenia tlačidla
 - napájanie 12V~ 50Hz 8VA

BELL 8VA 12V~1M

- signal bell
 - the sound emission has the same lasting time as the control operation
 - supply voltage 12V~ 50Hz 8VA

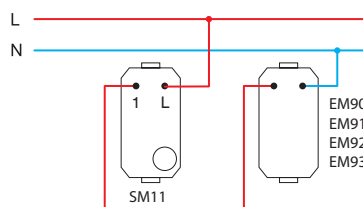
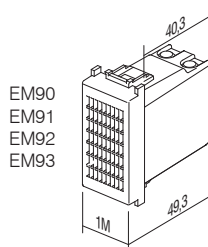
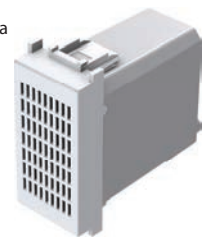

REGULÁTOR HLASITOSTI PRE 100V AUDIO VSTUP 35W 2M



- EM95PW
- EM95SB
- EM95ES
- EM95IW

- regulátor hlasitosti (atenuátor) pre 100V audio systémy
- menovitý výkon 35W (max. 45W), 6 stupňové nastavenie hlasitosti
- vhodný pre inštaláciu do hlbokých krabíc (najmenej 60mm)
- nie je vhodný pre inštaláciu do krabíc hlbokých 45mm a povrchových montážnych krabíc CUBO IP20
- len na vnútorné použitie

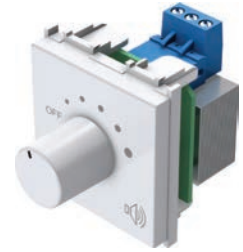

VOLUME CONTROL 100V AUDIO LINE 35W 2M

- volume control (attenuator) for 100V audio systems
- power rating 35W (max. 45W), 6 steps volume control
- suitable for boxes min. 60 mm deep
- not suitable for installation in 45 mm deep boxes and surface mount boxes CUBO IP20
- for indoor use only

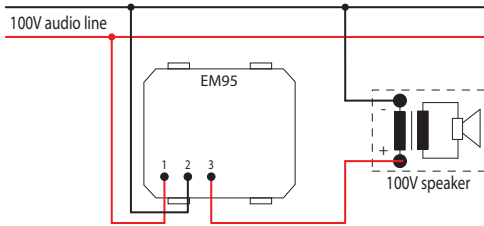

REGULÁTOR HLASITOSTI NÍZKO-NAPĚŤOVÝ 4 – 8 Ω 35W 2M



- EM96PW
- EM96SB
- EM96ES
- EM96IW

- regulátor hlasitosti pre nízko-napäťové výstupy 4 – 8 Ω 35W
- na pripojenie Hi-Fi zariadenia
- menovitý výkon 35W, 6 stupňové nastavenie hlasitosti
- vhodný pre inštaláciu do hlbokých krabíc (najmenej 60mm)
- nie je vhodný pre inštaláciu do krabíc hlbokých 45mm a povrchových montážnych krabíc CUBO IP20
- len na vnútorné použitie



VOLUME CONTROL 4-8 Ω 35W 2M

- volume control (attenuator) for low voltage outputs 4-8 Ω, 35W
- for connecting to Hi-Fi systems
- power rating 35W, 6 steps volume control
- suitable for boxes min. 60 mm deep
- not suitable for installation in 45 mm deep boxes and surface mount boxes CUBO IP20
- for indoor use only

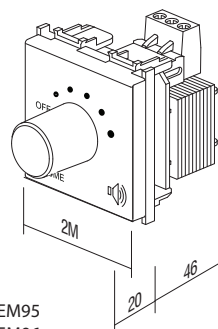
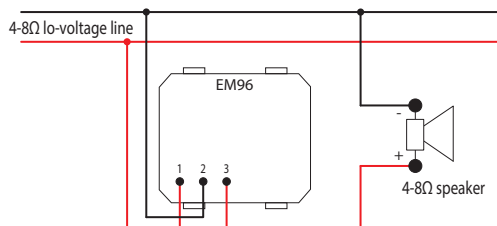

EM95
EM96

S E T S C M



CM25

PW

OS

Typ type	názov description	technické údaje technical data	veľkosť size	farba colour	fakultatívny opis 1 optional data 1
CM10	SADA ZÁSUVIEK 2x SCHUKO SOCKET SET 2x SCHUKO	2P+E 16A 250V~	4M	<input type="checkbox"/> PW biely-lesklý polar white	<input type="checkbox"/> OL rámik LINE cover plate LINE
CM11	SADA ZÁSUVIEK 3x SCHUKO SOCKET SET 3x SCHUKO	2P+E 16A 250V~	7M	<input checked="" type="checkbox"/> SB čierna-matná soft touch black	<input type="checkbox"/> OS rámik SOFT cover plate SOFT
CM15	SADA ZÁSUVIEK FAREBNÁ LINK WIRE SET	3x1,5mm ²	1M	<input type="checkbox"/> ES strieborný-matný elox silver	
.	.	.	.	<input type="checkbox"/> IW slonová kosť-lesklý ivory white	

SADA ZÁSUVIEK 2x SCHUKO 2P+E 16A 250V~ 4M

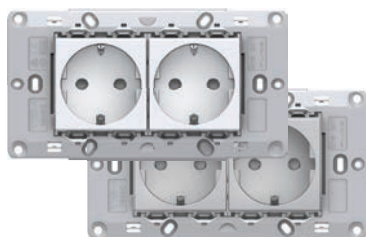

- CM10PW
- CM10ES

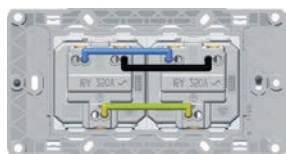

- sada zásuviek 2x schuko VM10 2P+E 16A 250V~
- zásuvky spojené upínačmi CM16
- s montážnym rámikom 4M bez skrutiek
- na upevnenie montážnych dosiek použít skrutky CM17, CM18 alebo CM19
- skrutkové upevnenie vodičov 1,5-2,5 mm²
- vyhovuje IEC 60884-1, CEE7

SOCKETS SET 2x SCHUKO 2P+E 16A 250V~ 4M

- socket set 2x schuko VM10 2P+E 16A 250V~
- prewired with link wires CM16
- with mounting frame 4M without screws
- for mounting frame fixing use screws CM17, CM18 or CM19
- screw contacts 1.5-2.5 mm²
- in accordance with IEC-60884-1, CEE7

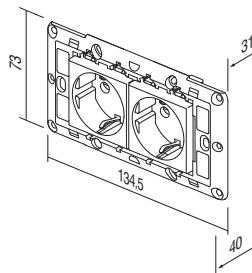

SADA ZÁSUVIEK 3x SCHUKO 2P+E 16A 250V~ 7M

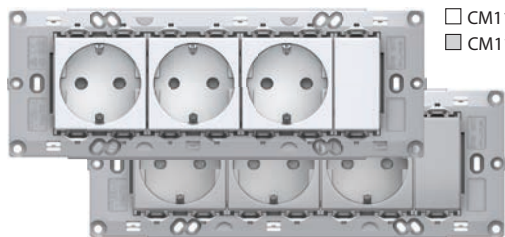

- CM11PW
- CM11ES

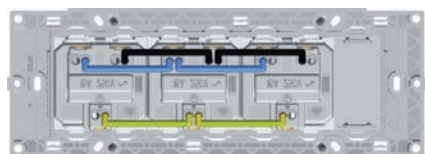

- sada zásuviek 3x schuko VM10 2P+E 16A 250V~
- zásuvky spojené upínačmi CM16
- s montážnym rámikom 7M bez skrutiek
- na upevnenie montážnych dosiek použít skrutky CM17, CM18 alebo CM19
- skrutkové upevnenie vodičov 1,5 - 2,5 mm²
- vyhovuje IEC 60884-1, CEE7

SOCKETS SET 3x SCHUKO 2P+E 16A 250V~ 7M

- socket set 3x schuko VM10 2P+E 16A 250V~
- prewired with link wires CM16
- with mounting frame 7M without screws
- for mounting frame fixing use screws CM17, CM18 or CM19
- screw contacts 1.5-2.5 mm²
- in accordance with IEC-60884-1, CEE7

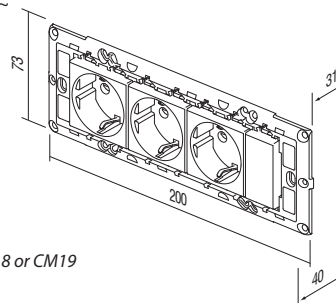

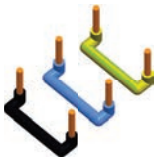
SADA FAREBNÝCH PREPOJOVACÍCH VODIČOV 3x1,5mm² 1M

CM15

- sada upínačov na spojenie dvoch prvkov veľkosti 1M
- obsahuje 10 čiernych, 10 modrých a 10 žltô-zelených upínačov

LINK WIRE SET 3x1,5mm² 1M

- link wire set to connect two elements size 1M
- includes 10 black, 10 blue and 10 yellow/green wires

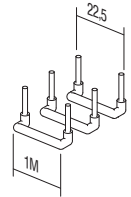
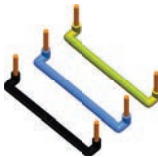
SADA FAREBNÝCH PREPOJOVACÍCH VODIČOV 3x2,5mm² 2M

CM16

- sada upínačov na spojenie dvoch prvkov veľkosti 2M
- obsahuje 10 čiernych, 10 modrých a 10 žltô-zelených upínačov

LINK WIRE SET 3x2,5mm² 2M

- link wire set to connect two elements size 2M
- includes 10 black, 10 blue and 10 yellow/green wires

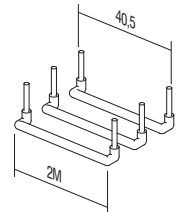

SADA SKRUTIEK 3,5



CM17
CM18
CM19

- sada skrutiek na upevnenie montážnych dosiek sád NM32, NM40, NM41, NM70
- CM17 - l=20mm, 100 ks
- CM18 - l=35mm, 50 ks
- CM19 - l=50mm, 50 ks

SCREW SET 3,5

- screw set for fixing mounting frames NM30, NM32, NM40, NM41, NM70
- CM17 - l=20mm, 100pcs
- CM18 - l=35mm, 50pcs
- CM19 - l=50mm, 50pcs

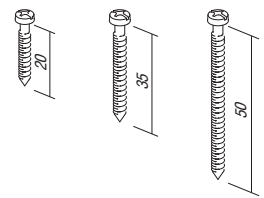

SADA PRE SPÍNAČE IP44 2M



□ CM22PW

- pre inštaláciu vo vlhkých priestoroch
- IP44 zabezpečuje ochranu pre všetky spínače Modul
- spínače a tlačidlá nie sú súčasťou sady – rámik SOFT 2M s popisným štítkom
- vyhovuje IEC 60669-1

SET SWITCHES IP44 2M

- for usage in humid areas
- IP44 protection provides for all Modul switches
- switches and buttons are not part of the set
- SOFT 2M cover plate with inscription plate
- in accordance with IEC 60669-1



SADA PRE ZÁSUVKY IP44 2M



□ CM23PW

- pre inštaláciu vo vlhkých priestoroch
- IP44 zabezpečuje ochranu len v kombinácii so zásuvkou s krytom (VM11, VM41)
- zásuvky nie sú súčasťou sady – rámik SOFT 2M s popisným štítkom
- vyhovuje IEC 60884-1
- in accordance with IEC 60884-1

SET SOCKETS IP44 2M

- for usage in humid areas
- IP44 protection can be achieved only in combination with covered socket (VM11, VM41)
- sockets are not part of the set
- SOFT 2M cover plate with inscription plate
- in accordance with IEC 60884-1



KÚPEĽŇOVÁ SADA 3x20AX 250V~ 4M

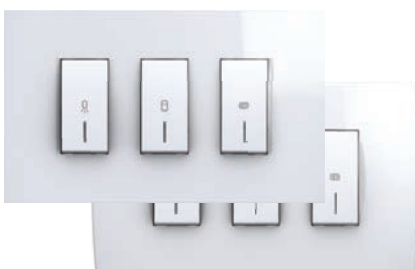

□ CM25PWOL
■ CM25IWOL

□ CM25PWOS
■ CM25IWOS

- sada spínačov 3xSM12 20AX 250V~ s montážnym rárikom a rárikom
- skrutkové upevnenie vodičov 1,5-2,5 mm²
- vyhovuje EN 60669-1
- možnosť upevnenia na už nainštalované krabice rozmerov upevnenia od 108 do 135 mm alebo na krabice veľkosti 4M
- výška rárika 90 mm

SWITCH SET FOR BATHROOM 3x20AX 250V~ 4M

- switch set 3xSM12 20AX 250V~ with mounting frame and cover plate
- screw contacts 1.5-2.5mm²
- in accordance with EN 60669-1
- universal solution for renovation on boxes with fixing dimensions 108-135mm or boxes 4M size
- cover plate height 90mm

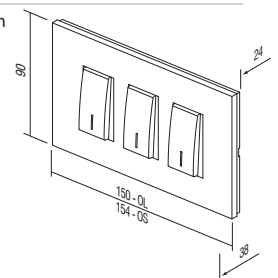



NM41

KÚPEĽŇOVÝ MONTÁŽNY RÁMIK 4M

- montážny rámik kúpeľňová sada so skrutkami
- možnosť upevnenia na už nainštalované obdĺžnikové krabice rozmerov upevnenia od 108 do 135 mm alebo na krabice veľkosti 4M
- vyhovuje EN 60669-1

MOUNTING FRAME BATHROOM SET 4M

- universal mounting frame for bathroom set with screws
- universal solution for mounting on rectangular boxes with fixing dimensions 108-135mm or boxes 4M size
- in accordance with EN 60669-1

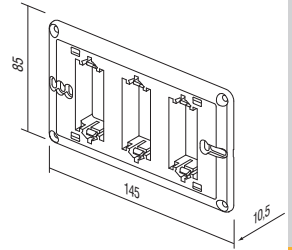

	OL41PW
	OL41NB
	OL41IW
	OL41ES
	OL41SG
	OL41IB
	OL41MG

RÁMIK LINE KÚPEĽŇOVÁ SADA

- dekoratívny rámik kúpeľňová sada LINE
- výška 90 mm
- vyhovuje EN 60669-1

COVER PLATE LINE BATHROOM SET

- decorative cover plate bathroom set LINE
- height 90mm
- in accordance with EN 60669-1

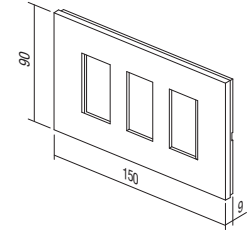

	OS41PW
	OS41NB
	OS41IW
	OS41ES
	OS41SG
	OS41SB
	OS41WE

RÁMIK SOFT KÚPEĽŇOVÁ SADA

- dekoratívny rámik kúpeľňová sada SOFT
- výška 90 mm
- vyhovuje EN 60669-1

COVER PLATE SOFT BATHROOM SET

- decorative cover plate bathroom set SOFT
- height 90mm
- in accordance with EN 60669-1

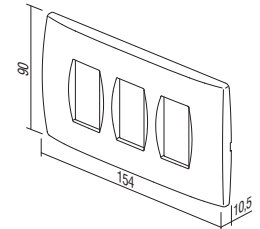

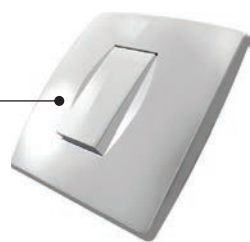



TM11



AW

IN

typ type	názov description	veľkosť size	farba colour	fakultatívny opis 1 optional data 1
TM11	KRYTKA NA SPÍNAČ BUTTON	1M	<input type="checkbox"/> AW antibakteriálna biela antibacterial white	 NT neutrálny neutral
TM21	VÝPLŇ BLANK	1M		 IN indikátor indicator
VM10	ZÁSUVKA SOCKET	2M		
.
.

ANTIBAKTERIÁLNY PROGRAM MODUL

- spínače a zásuvky sú denne vystavené dotyku mnohých ľudí, a preto ide o časté miesto pre tvorbu a šírenie baktérií
- vďaka svojim prírodným antibakteriálnym vlastnostiam sa striebro už 3 tisícročia používa ako bezpečný a účinný dezinfekčný prostriedok, pretože je úplne prirodzené, zdravé a šetrné k životnému prostrediu
- špeciálne antibakteriálne strieborné ióny zaručujú dlhodobú, spoľahlivú a účinnú ochranu pred tvorbou a šírením rôznych baktérií, vírusov, mikroorganizmov a plesní
- antibakteriálna ochrana zabezpečuje väčšiu hygienu, čistotu a zdravie ľudí
- antibakteriálny program MODUL je vhodný na použitie v prostredí s prísnyimi hygienickými podmienkami (nemocnice, zdravotné strediská, farmaceutické zariadenia, domovy dôchodcov, opatrovatelské domy, laboratória, reštaurácie, hotely, letiská, autobusové a železničné stanice, obchodné a nákupné centrá, verejné inštitúcie ...)
- laboratórne skúšky boli vykonané v nezávislej inštitúcii v súlade s najvyššími japonskými normami JIS Z 2801
- nízke náklady na zabezpečenie ľudského zdravia
- dizajn a funkčnosť antibakteriálneho programu MODUL umožňuje jednoduché čistenie a údržbu
- antibakteriálny program MODUL obsahuje antibakteriálne tlačidlá, rámy a zásuvky, spolu s klasickými úchytami a spínačmi
- každý výrobok je kvôli jednoduchšej identifikácii označený na zadnej strane skratkou AW (antibacterial white)

ANTIBACTERIAL PROGRAM MODUL

- switches and sockets are daily touched by many people, so this is a common place for development and spread of bacteria
- thanks to its natural antibacterial characteristics silver has been used for three millennia as a safe and effective disinfectant, since it is completely natural, healthy and environmentally friendly
- special antibacterial silver ions additive provides long-term, reliable and effective protection against the development and spread of bacteria, viruses, microbes and fungi
- antibacterial protection ensures hygiene, cleanliness and health for people
- perfectly suitable for use in environments with strict hygiene conditions (hospitals, health centers, pharmaceutical facilities, homes for elderly, nursing homes, laboratories, restaurants, hotels, airports, bus and railway stations, business and shopping areas, public institutions ...)
- independent laboratory testings have been carried out in accordance with highest Japanese standards JIS Z 2801
- low cost for providing human health
- design and functionality of antibacterial program MODUL allow easy cleaning and maintenance
- antibacterial buttons, cover plates and sockets are combined with classic mounting frames and switches
- products are labelled on the back with AW (antibacterial white)

A N T I B A C T E R I A L P R O G R A M M O D U L

KRYTKA NA SPÍNAČ 1M



□ TM11AW

- vymeniteľná krytka spínača 1M
- vyhovuje EN 60669-1
- antibakteriálna ochrana v súlade s JIS Z 2801

BUTTON 1M

- replaceable button 1M
- in accordance with EN 60669-1
- antibacterial protection in accordance with JIS Z 2801



KRYTKA NA SPÍNAČ 1M INDIKÁTOR



□ TM11AWIN

- vymeniteľná krytka spínača 1M
- vyhovuje EN 60669-1
- antibakteriálna ochrana v súlade s JIS Z 2801

BUTTON 1M INDICATOR

- replaceable button 1M
- in accordance with EN 60669-1
- antibacterial protection in accordance with JIS Z 2801



KRYTKA NA SPÍNAČ 2M



□ TM12AW

- vymeniteľná krytka spínača 2M s úchytkou krytky
- používa sa pri nadstavbe spínača alebo krytky spínača 1M na veľkosť 2M
- vyhovuje EN 60669-1
- antibakteriálna ochrana v súlade s JIS Z 2801

BUTTON 2M

- replaceable button 2M with button carrier
- to upgrade switch or push button from size 1M to size 2M
- in accordance with EN 60669-1
- antibacterial protection in accordance with JIS Z 2801



KRYTKA NA SPÍNAČ 2M INDIKÁTOR



□ TM12AWIN

- vymeniteľná krytka spínača 2M s úchytkou krytky
- používa sa pri nadstavbe spínača alebo krytky spínača 1M na veľkosť 2M
- vyhovuje EN 60669-1
- antibakteriálna ochrana v súlade s JIS Z 2801

BUTTON 2M INDICATOR

- replaceable button 2M with button carrier
- to upgrade switch or push button from size 1M to size 2M
- in accordance with EN 60669-1
- antibacterial protection in accordance with JIS Z 2801



VÝPLŇ 1M



□ TM21AW

- na vyplnenie prázdnych miest
- vyhovuje EN 60669-1
- antibakteriálna ochrana v súlade s JIS Z 2801

BLANK 1M

- blank modul to fill up empty spaces
- in accordance with EN 60669-1
- antibacterial protection in accordance with JIS Z 2801



VÝPLŇ 2M



□ TM22AW

- na vyplnenie prázdnych miest
- vyhovuje EN 60669-1
- antibakteriálna ochrana v súlade s JIS Z 2801

BLANK 2M

- blank modul to fill up empty spaces
- in accordance with EN 60669-1
- antibacterial protection in accordance with JIS Z 2801





□ VM10AW

ZÁSUVKA SCHUKO+KS 2P+E 16A 250V~ 2M

- 2P+E schuko
- 16A 250 V~, typ VM10
- vyhovuje IEC 60884-1, CEE7
- skrutkové upevnenie vodičov 1,5 – 2,5 mm²
- KS zabudovaná detská ochrana pred dotykom kontaktov
- antibakteriálna ochrana v súlade s JIS Z 2801

SOCKET SCHUKO+KS 2P+E 16A 250V~ 2M

- 2P+E schuko
- 16A 250V~, type VM10
- in accordance with IEC 60884-1, CEE7
- screw contacts 1.5-2.5 mm²
- KS built-in child protection - shuttered live contacts
- antibacterial protection in accordance with JIS Z 2801



□ VM11AW

ZÁSUVKA SCHUKO+KS+KRYT 2P+E 16A 250V~ 2M

- 2P+E schuko+kryt
- 16A 250 V~, typ VM11
- vyhovuje IEC 60884-1, CEE7
- skrutkové upevnenie vodičov 1,5 – 2,5 mm²
- KS zabudovaná detská ochrana pred dotykom kontaktov
- antibakteriálna ochrana v súlade s JIS Z 2801

SOCKET SCHUKO+KS+COVER

- 2P+E 16A 250V~ 2M
- 2P+E schuko+cover
- 16A 250V~, type VM11
- in accordance with IEC 60884-1, CEE7
- screw contacts 1.5-2.5 mm²
- KS built-in child protection - shuttered live contacts
- antibacterial protection in accordance with JIS Z 2801



□ VM20AW

ZÁSUVKA EURO+KS 2P 10A 250V~ 1M

- 2P euro
- 10A 250 V~, typ VM20
- vyhovuje IEC 60884-1, CEE7
- skrutkové upevnenie vodičov 1,5 – 2,5 mm²
- KS zabudovaná detská ochrana pred dotykom kontaktov
- antibakteriálna ochrana v súlade s JIS Z 2801

SOCKET EURO+KS 2P 10A 250V~ 1M

- 2P Euro
- 10A 250V~, type VM20
- in accordance with IEC 60884-1, CEE7
- screw contacts 1.5-2.5 mm²
- KS built-in child protection - shuttered live contacts
- antibacterial protection in accordance with JIS Z 2801



□ KM11AW

ZÁSUVKA TV KONCOVÁ 1dB 1M

- koncová
- frekvenčné pásmo 5÷2400 MHz
- útlm < 1 dB
- vyhovuje EN 50083-1
- skrutkové upevnenie
- antibakteriálna ochrana v súlade s JIS Z 2801

SOCKET TV END-LINE 1dB 1M

- TV end-line
- frequency range 5÷2400 MHz
- reduction < 1 dB
- in accordance with EN 50083-1
- screw contacts
- antibacterial protection in accordance with JIS Z 2801

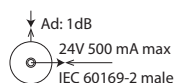

□ KM35AW

ADAPTÉR KS 1M

- KS keystone štandard pripojenia
- AMP, Avaya, Brandrex, FMT, Mfico, Tyco, ...
- neobsahuje komunikačný modul
- antibakteriálna ochrana v súlade s JIS Z 2801

ADAPTER KS 1M

- KS keystone standard ugradnje
- AMP, Avaya, Brandrex, FMT, Mfico, Tyco, ...
- komunikacijski modul nije uključen
- antibakterijska zaštita usklađena s JIS Z 2801



A N T I B A C T E R I A L P R O G R A M M O D U L



OS20AW

RÁMIK SOFT 2M

- dekoratívny rámik SOFT 2M
- vyhovuje EN 60669-1
- antibakteriálna ochrana v súlade s JIS Z 2801

COVER PLATE SOFT 2M

- decorative cover plate SOFT 2M
- in accordance with EN 60669-1
- antibacterial protection in accordance with JIS Z 2801



OS24AW

RÁMIK SOFT 2x2M

- dekoratívny rámik SOFT 2x2M
- horizontálne alebo vertikálne zabudovanie
- vyhovuje EN 60669-1
- antibakteriálna ochrana v súlade s JIS Z 2801

COVER PLATE SOFT 2x2M

- decorative cover plate SOFT 2x2M
- horizontal or vertical mounting
- in accordance with EN 60669-1
- antibacterial protection in accordance with JIS Z 2801



OS26AW

RÁMIK SOFT 3x2M

- dekoratívny rámik SOFT 3x2M
- horizontálne alebo vertikálne zabudovanie
- vyhovuje EN 60669-1
- antibakteriálna ochrana v súlade s JIS Z 2801

COVER PLATE SOFT 3x2M

- decorative cover plate SOFT 3x2M
- horizontal or vertical mounting
- in accordance with EN 60669-1
- antibacterial protection in accordance with JIS Z 2801



OS30AW

RÁMIK SOFT 3M

- dekoratívny rámik SOFT 3M
- vyhovuje EN 60669-1
- antibakteriálna ochrana v súlade s JIS Z 2801

COVER PLATE SOFT 3M

- decorative cover plate SOFT 3M
- in accordance with EN 60669-1
- antibacterial protection in accordance with JIS Z 2801



OS40AW

RÁMIK SOFT 4M

- dekoratívny rámik SOFT 4M
- vyhovuje EN 60669-1
- antibakteriálna ochrana v súlade s JIS Z 2801

COVER PLATE SOFT 4M

- decorative cover plate SOFT 4M
- in accordance with EN 60669-1
- antibacterial protection in accordance with JIS Z 2801



OS70AW

RÁMIK SOFT 7M

- dekoratívny rámik SOFT 7M
- vyhovuje EN 60669-1
- antibakteriálna ochrana v súlade s JIS Z 2801

COVER PLATE SOFT 7M

- decorative cover plate SOFT 7M
- in accordance with EN 60669-1
- antibacterial protection in accordance with JIS Z 2801

kov
metal

MH kovaná oceľ
hammered steel



MS satinované striebro
satin silver

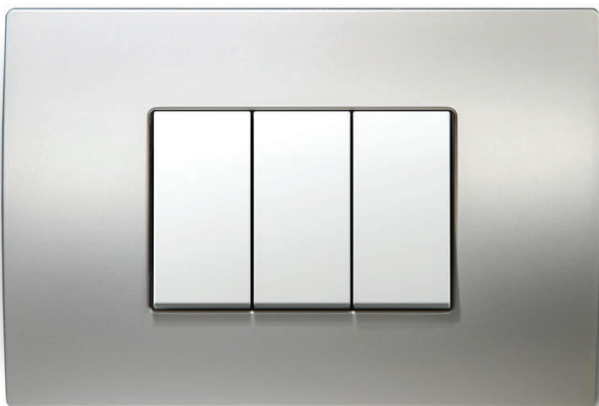

ME hrdzavé železo
etched iron

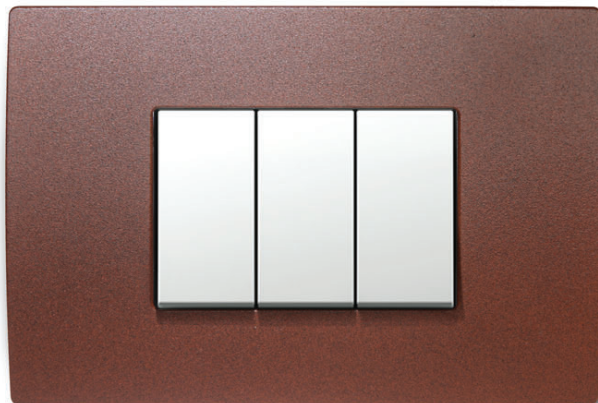

MN satinovaný nikel
satin nickel

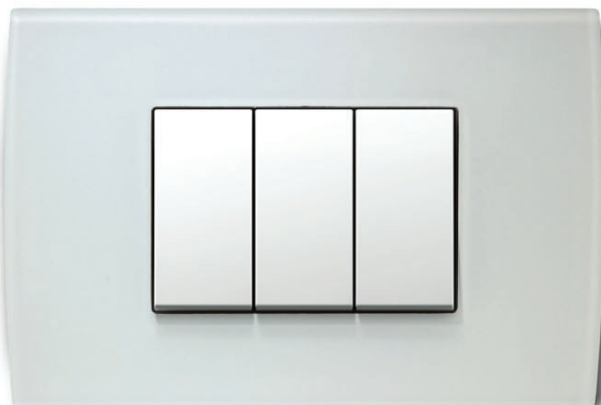
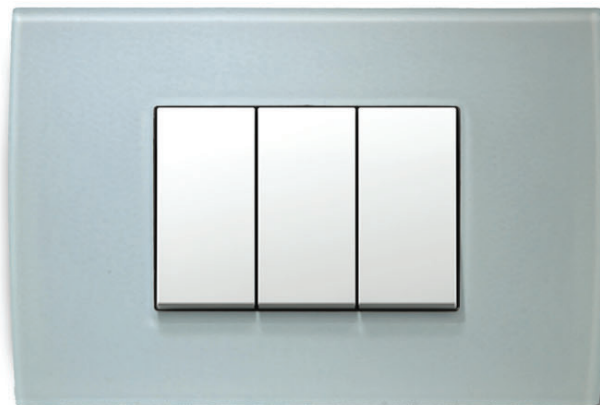
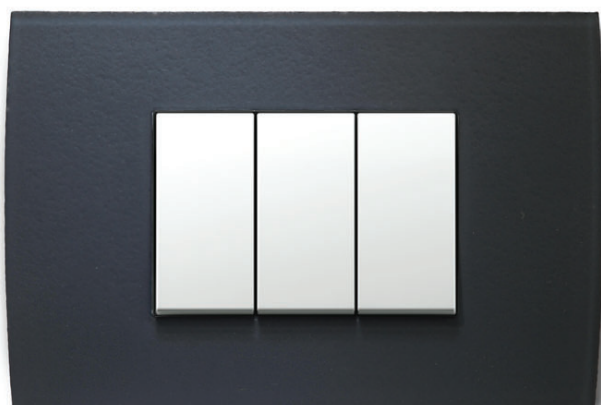
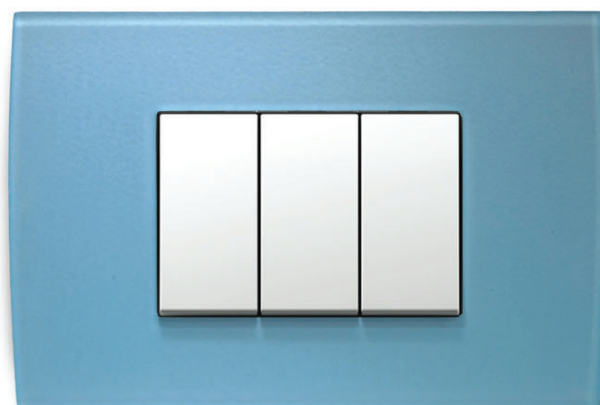

COVER PLATES PURE OP

drevo
woodWB bambus
bambooWW orech
walnutWM javor
mapleWE wenge
wengesklo
glassGW ľadová biela
ice whiteGG ľadová zelená
ice greenGY ľadová sivá
ice greyGB ľadová modrá
ice blue



OP30



WB

Typ type	názov description	velkosť size	farba colour
OP13	RÁMIK PURE COVER PLATE PURE	1/3M	MH kovaná oceľ hammered steel
OP20	RÁMIK PURE COVER PLATE PURE	2M	ME hrdzavé železo etched iron
OP23	RÁMIK PURE COVER PLATE PURE	2/3M	MS satínované striebro satin silver
.	.	.	MN satínovaný nikel satin nickel
.	.	.	WB bambus bamboo
.	.	.	WW orech walnut
.	.	.	WM javor maple
.	.	.	WE wenge wenge
.	.	.	GW ľadovo biely ice white
.	.	.	GG ľadovo zelený ice green
.	.	.	GY ľadovo sivý ice grey
.	.	.	GB ľadovo modrý ice blue



OP20MH	OP20WB
OP20ME	OP20WW
OP20MS	OP20WM
OP20MN	OP20WE
	OP20GW
	OP20GG
	OP20GY
	OP20GB

RÁMIK PURE 2M

- dekoratívny rámik PURE 2M
- vyhovuje EN 60669-1
- iba v kombinácii s montážnymi rámikmi NM24 alebo NM25

COVER PLATE PURE 2M

- decorative cover plate PURE 2M
- in accordance with EN 60669-1
- only in combination with mounting frames NM24 or NM25



OP24MH	OP24WB
OP24ME	OP24WW
OP24MS	OP24WM
OP24MN	OP24WE
	OP24GW
	OP24GG
	OP24GY
	OP24GB

RÁMIK PURE 2x2M

- dekoratívny rámik PURE 2x2M
- horizontálna alebo vertikálna montáž
- vyhovuje EN 60669-1
- iba v kombinácii s montážnymi rámikmi NM24 alebo NM25

COVER PLATE PURE 2x2M

- decorative cover plate PURE 2x2M
- horizontal or vertical mounting
- in accordance with EN 60669-1
- only in combination with mounting frames NM24 or NM25



OP26MH	OP26WB
OP26ME	OP26WW
OP26MS	OP26WM
OP26MN	OP26WE
	OP26GW
	OP26GG
	OP26GY
	OP26GB

RÁMIK PURE 3x2M

- dekoratívny rámik PURE 3x2M
- horizontálna alebo vertikálna montáž
- vyhovuje EN 60669-1
- iba v kombinácii s montážnymi rámikmi NM24 alebo NM25

COVER PLATE PURE 3x2M

- decorative cover plate PURE 3x2M
- horizontal or vertical mounting
- in accordance with EN 60669-1
- only in combination with mounting frames NM24 or NM25

COVER PLATES PURE OP



OP30MH
OP30ME
OP30MS
OP30MN

OP30WB
OP30WW
OP30WM
OP30WE
OP30GW
OP30GG
OP30GY
OP30GB

RÁMIK PURE 3M

- dekoratívny rámik PURE 3M
- vyhovuje EN 60669-1

COVER PLATE PURE 3M

- decorative cover plate PURE 3M
- in accordance with EN 60669-1



OP40MH
OP40ME
OP40MS
OP40MN

OP40WB
OP40WW
OP40WM
OP40WE
OP40GW
OP40GG
OP40GY
OP40GB

RÁMIK PURE 4M

- dekoratívny rámik PURE 4M
- vyhovuje EN 60669-1

COVER PLATE PURE 4M

- decorative cover plate PURE 4M
- in accordance with EN 60669-1



OP70MH
OP70ME
OP70MS
OP70MN

OP70WB
OP70WW
OP70WM
OP70WE
OP70GW
OP70GG
OP70GY
OP70GB

RÁMIK PURE 7M

- dekoratívny rámik PURE 7M
- vyhovuje EN 60669-1

COVER PLATE PURE 7M

- decorative cover plate PURE 7M
- in accordance with EN 60669-1



OP13MH
OP13ME
OP13MS
OP13MN

OP13WB
OP13WW
OP13WM
OP13WE
OP13GW
OP13GG
OP13GY
OP13GB

RÁMIK PURE 1/3M

- dekoratívny rámik PURE 1/3M
- vyhovuje EN 60669-1

COVER PLATE PURE 1/3M

- decorative cover plate PURE 1/3M
- in accordance with EN 60669-1



OP23MH
OP23ME
OP23MS
OP23MN

OP23WB
OP23WW
OP23WM
OP23WE
OP23GW
OP23GG
OP23GY
OP23GB

RÁMIK PURE 2/3M

- dekoratívny rámik PURE 2/3M
- vyhovuje EN 60669-1

COVER PLATE PURE 2/3M

- decorative cover plate PURE 2/3M
- in accordance with EN 60669-1

basic
basic

PW biely - lesklý
polar white

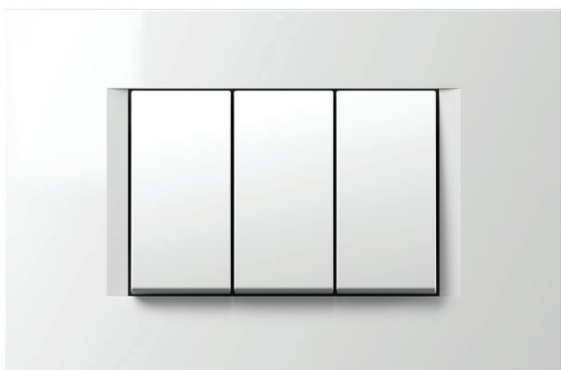

IW slonová kosť - lesklý
ivory white

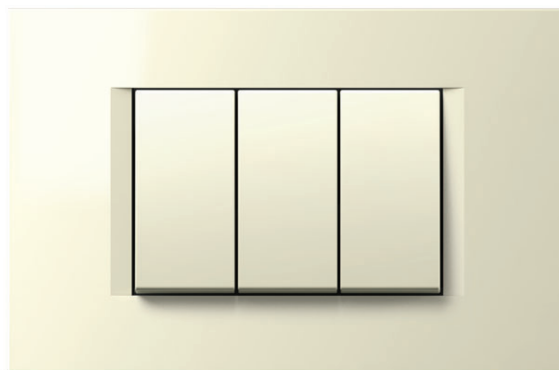

ES strieborný - matný
elox silver



SB čierny - matný
soft touch black

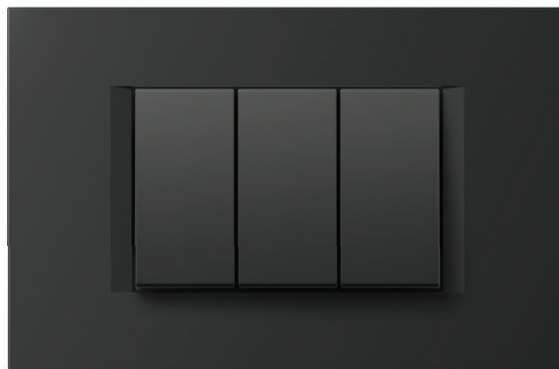

COVER PLATES LINE OL

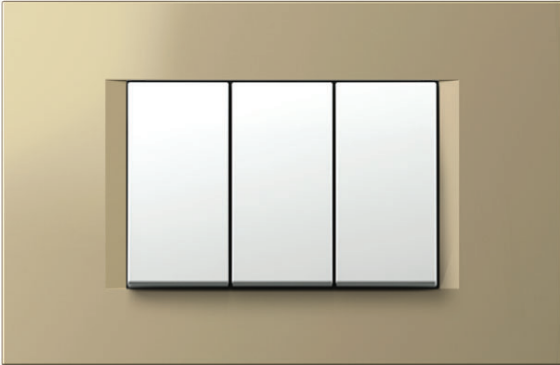
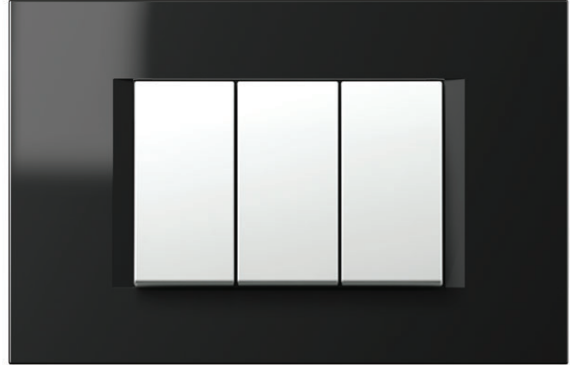
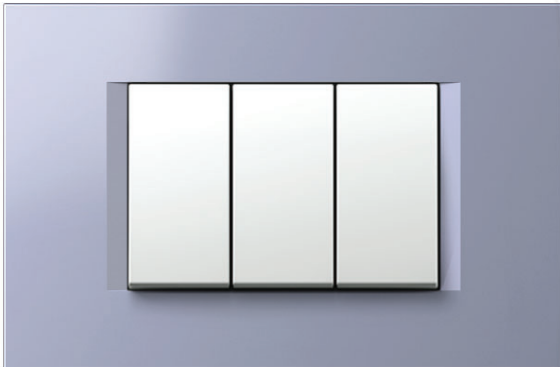
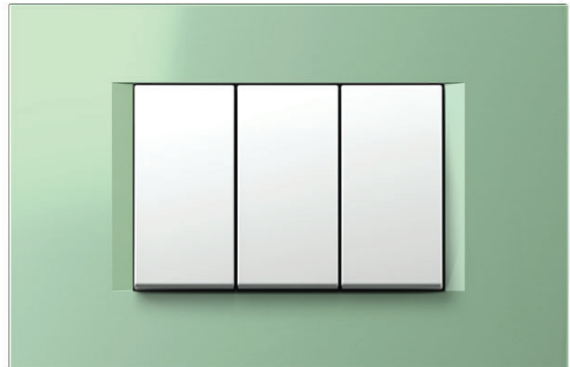
decor
decorSG zlatý - matný
sand goldNB čierny - lesklý
night blackIB modrý - matný
impulse blueMG zelený - matný
mint greenSE kameň emerald
stone emeraldSW kameň biely
stone white



OL30

PW

Typ type	názov description	veľkosť size	farba colour												
OL10	RÁMIK LINE COVER PLATE LINE	1/2M	<table border="0"> <tr> <td></td> <td>PW biely-lesklý polar white</td> <td></td> <td>SG zlatá-matná sand gold</td> <td></td> <td>SE kameň emerald stone emerald</td> </tr> </table>		PW biely-lesklý polar white		SG zlatá-matná sand gold		SE kameň emerald stone emerald						
	PW biely-lesklý polar white		SG zlatá-matná sand gold		SE kameň emerald stone emerald										
OL13	RÁMIK LINE COVER PLATE LINE	1/3M	<table border="0"> <tr> <td></td> <td>IW slonová kosť-lesklý ivory white</td> <td></td> <td>NB čierny-lesklý night black</td> <td></td> <td>SW kameň biely stone white</td> </tr> </table>		IW slonová kosť-lesklý ivory white		NB čierny-lesklý night black		SW kameň biely stone white						
	IW slonová kosť-lesklý ivory white		NB čierny-lesklý night black		SW kameň biely stone white										
OL20	RÁMIK LINE COVER PLATE LINE	2M	<table border="0"> <tr> <td></td> <td>ES strieborný-matný elox silver</td> <td></td> <td>IB modrá-matná impulse blue</td> <td></td> <td></td> </tr> <tr> <td></td> <td>SB čierna-matná soft touch black</td> <td></td> <td>MG zelená-matná mint green</td> <td></td> <td></td> </tr> </table>		ES strieborný-matný elox silver		IB modrá-matná impulse blue				SB čierna-matná soft touch black		MG zelená-matná mint green		
	ES strieborný-matný elox silver		IB modrá-matná impulse blue												
	SB čierna-matná soft touch black		MG zelená-matná mint green												



RÁMIK LINE 2M



	OL20PW		OL20SG
	OL20IW		OL20NB
	OL20ES		OL20IB
	OL20SB		OL20MG
			OL20SE
			OL20SW

- dekoratívny rámik LINE 2M
- vyhovuje EN 60669-1

COVER PLATE LINE 2M
- decorative cover plate LINE 2M
- in accordance with EN 60669-1

RÁMIK LINE 2x2M



	OL24PW		OL24SG
	OL24IW		OL24NB
	OL24ES		OL24IB
	OL24SB		OL24MG
			OL24SE
			OL24SW

- dekoratívny rámik LINE 2x2M
- horizontálna alebo vertikálna montáž
- vyhovuje EN 60669-1

COVER PLATE LINE 2x2M
- decorative cover plate LINE 2x2M
- horizontal or vertical mounting
- in accordance with EN 60669-1

RÁMIK 3x2M

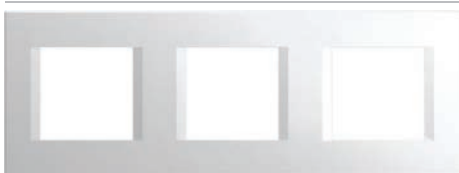

	OL26PW		OL26SG
	OL26IW		OL26NB
	OL26ES		OL26IB
	OL26SB		OL26MG
			OL26SE
			OL26SW

- dekoratívny rámik LINE 3x2M
- horizontálna alebo vertikálna montáž
- vyhovuje EN 60669-1

COVER PLATE LINE 3x2M
- decorative cover plate LINE 3x2M
- horizontal or vertical mounting
- in accordance with EN 60669-1

RÁMIK 4x2M



	OL28PW		OL28SG
	OL28IW		OL28NB
	OL28ES		OL28IB
	OL28SB		OL28MG
			OL28SE
			OL28SW

- dekoratívny rámik LINE 4x2M
- horizontálna alebo vertikálna montáž
- vyhovuje EN 60669-1

COVER PLATE LINE 4x2M
- decorative cover plate LINE 4x2M
- horizontal or vertical mounting
- in accordance with EN 60669-1

COVER PLATES LINE OL



 OL30PW	 OL30SG
 OL30IW	 OL30NB
 OL30ES	 OL30IB
 OL30SB	 OL30MG
	 OL30SE
	 OL30SW

RÁMIK 3M

- dekoratívny rámik LINE 3M
- vyhovuje EN 60669-1

COVER PLATE LINE 3M

- decorative cover plate LINE 3M
- in accordance with EN 60669-1



 OL40PW	 OL40SG
 OL40IW	 OL40NB
 OL40ES	 OL40IB
 OL40SB	 OL40MG
	 OL40SE
	 OL40SW

RÁMIK 4M

- dekoratívny rámik LINE 4M
- vyhovuje EN 60669-1

COVER PLATE LINE 4M

- decorative cover plate LINE 4M
- in accordance with EN 60669-1



 OL70PW	 OL70SG
 OL70IW	 OL70NB
 OL70ES	 OL70IB
 OL70SB	 OL70MG
	 OL70SE
	 OL70SW

RÁMIK 7M

- dekoratívny rámik LINE 7M
- vyhovuje EN 60669-1

COVER PLATE LINE 7M

- decorative cover plate LINE 7M
- in accordance with EN 60669-1



 OL10PW	 OL10SG
 OL10IW	 OL10NB
 OL10ES	 OL10IB
 OL10SB	 OL10MG
	 OL10SE
	 OL10SW

RÁMIK 1/2M

- dekoratívny rámik LINE 1/2M
- vyhovuje EN 60669-1

COVER PLATE LINE 1/2M

- decorative cover plate LINE 1/2M
- in accordance with EN 60669-1



 OL13PW	 OL13SG
 OL13IW	 OL13NB
 OL13ES	 OL13IB
 OL13SB	 OL13MG
	 OL13SE
	 OL13SW

RÁMIK 1/3M

- dekoratívny rámik LINE 1/3M
- vyhovuje EN 60669-1

COVER PLATE LINE 1/3M

- decorative cover plate LINE 1/3M
- in accordance with EN 60669-1



 OL23PW	 OL23SG
 OL23IW	 OL23NB
 OL23ES	 OL23IB
 OL23SB	 OL23MG
	 OL23SE
	 OL23SW

RÁMIK 2/3M

- dekoratívny rámik LINE 2/3M
- vyhovuje EN 60669-1

COVER PLATE LINE 2/3M

- decorative cover plate LINE 2/3M
- in accordance with EN 60669-1

basic
basic

PW biely-lesklý
polar white

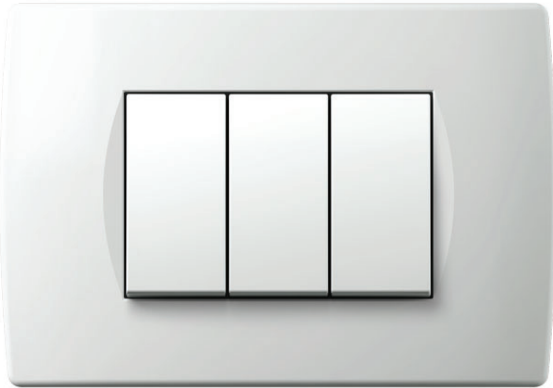

IW slonová kosť-lesklý
ivory white

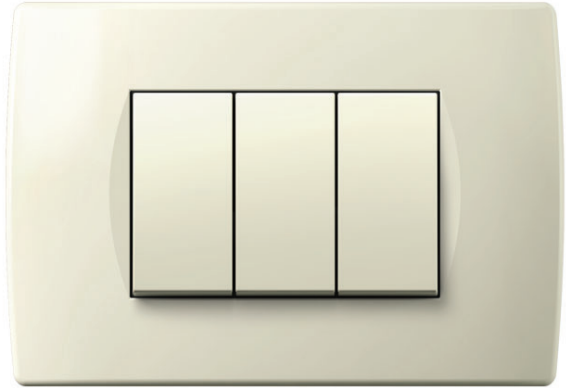

ES strieborný-matný
elox silver

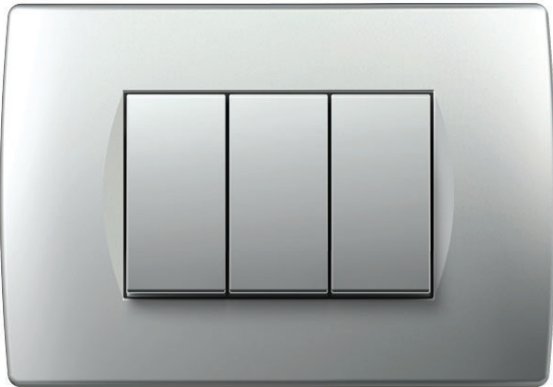

SB čierny-matný
soft touch black



decor
decor

SG zlatý - matný
sand gold

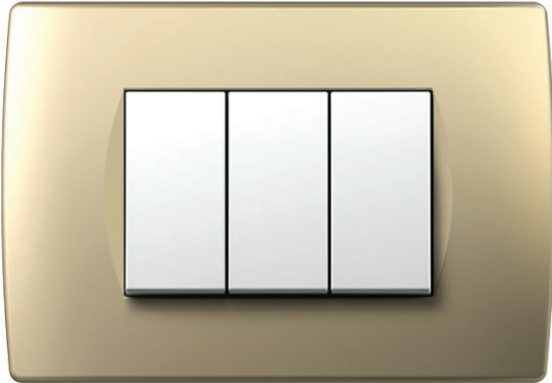

NB čierny - lesklý
night black



WP smrek
spruce



WW orech
walnut



WE wenge
wenge





OS30



PW

Typ type	názov description	veľkosť size	farba colour																								
OS10	RÁMIK SOFT COVER PLATE SOFT	1/2M	<table border="0"> <tr> <td></td> <td>PW biely-lesklý polar white</td> <td></td> <td>SG zlatá - matná sand gold</td> <td></td> <td>WP smrek spruce</td> </tr> <tr> <td></td> <td>IW slonová kosť-lesklý ivory white</td> <td></td> <td>NB čierny-lesklý night black</td> <td></td> <td>WW orech walnut</td> </tr> <tr> <td></td> <td>ES strieborný-matný elox silver</td> <td></td> <td>WE wenge wenge</td> <td></td> <td></td> </tr> <tr> <td></td> <td>SB čierna-matná soft touch black</td> <td></td> <td></td> <td></td> <td></td> </tr> </table>		PW biely-lesklý polar white		SG zlatá - matná sand gold		WP smrek spruce		IW slonová kosť-lesklý ivory white		NB čierny-lesklý night black		WW orech walnut		ES strieborný-matný elox silver		WE wenge wenge				SB čierna-matná soft touch black				
	PW biely-lesklý polar white		SG zlatá - matná sand gold		WP smrek spruce																						
	IW slonová kosť-lesklý ivory white		NB čierny-lesklý night black		WW orech walnut																						
	ES strieborný-matný elox silver		WE wenge wenge																								
	SB čierna-matná soft touch black																										
OS13	RÁMIK SOFT COVER PLATE SOFT	1/3M																									
OS20	RÁMIK SOFT COVER PLATE SOFT	2M																									
...																											



	OS20PW		OS20SG
	OS20IW		OS20NB
	OS20ES		OS20WP
	OS20SB		OS20WW
			OS20WE

RÁMIK SOFT 2M

- dekoratívny rámik SOFT 2M
- vyhovuje EN 60669-1

COVER PLATE SOFT 2M

- decorative cover plate SOFT 2M
- in accordance with EN 60669-1



	OS24PW		OS24SG
	OS24IW		OS24NB
	OS24ES		OS24WP
	OS24SB		OS24WW
			OS24WE

RÁMIK SOFT 2x2M

- dekoratívny rámik SOFT 2x2M
- horizontálna alebo vertikálna montáž
- vyhovuje EN 60669-1

COVER PLATE SOFT 2x2M

- decorative cover plate SOFT 2x2M
- horizontal or vertical mounting
- in accordance with EN 60669-1



	OS26PW		OS26SG
	OS26IW		OS26NB
	OS26ES		OS26WP
	OS26SB		OS26WW
			OS26WE

RÁMIK SOFT 3x2M

- dekoratívny rámik SOFT 3x2M
- horizontálna alebo vertikálna montáž
- vyhovuje EN 60669-1

COVER PLATE SOFT 3x2M

- decorative cover plate SOFT 3x2M
- horizontal or vertical mounting
- in accordance with EN 60669-1



	OS28PW		OS28SG
	OS28IW		OS28NB
	OS28ES		OS28WP
	OS28SB		OS28WW
			OS28WE

RÁMIK SOFT 4x2M

- dekoratívny rámik SOFT 4x2M
- horizontálna alebo vertikálna montáž
- vyhovuje EN 60669-1

COVER PLATE SOFT 4x2M

- decorative cover plate SOFT 4x2M
- horizontal or vertical mounting
- in accordance with EN 60669-1

COVER PLATES SOFT OS



 OS30PW	 OS30SG
 OS30IW	 OS30NB
 OS30ES	 OS30WP
 OS30SB	 OS30WW
	 OS30WE

RÁMIK SOFT 3M

- dekoratívny rámik SOFT 3M
- vyhovuje EN 60669-1

COVER PLATE SOFT 3M
- decorative cover plate SOFT 3M
- in accordance with EN 60669-1



 OS40PW	 OS40SG
 OS40IW	 OS40NB
 OS40ES	 OS40WP
 OS40SB	 OS40WW
	 OS40WE

RÁMIK SOFT 4M

- dekoratívny rámik SOFT 4M
- vyhovuje EN 60669-1

COVER PLATE SOFT 4M
- decorative cover plate SOFT 4M
- in accordance with EN 60669-1







 OS70PW	 OS70SG
 OS70IW	 OS70NB
 OS70ES	 OS70WP
 OS70SB	 OS70WW
	 OS70WE

RÁMIK SOFT 7M

- dekoratívny rámik SOFT 7M
- vyhovuje EN 60669-1

COVER PLATE SOFT 7M
- decorative cover plate SOFT 7M
- in accordance with EN 60669-1



 OS72PW
 OS72IW
 OS72ES
 OS72SB

RÁMIK SOFT 2x7M

- dekoratívny rámik SOFT 2x7M
s popisným štítkom
- vyhovuje EN 60669-1

COVER PLATE SOFT 2x7M
- decorative cover plate SOFT 2x7M with
inscription plate
- in accordance with EN 60669-1



 OS10PW	 OS10SG
 OS10IW	 OS10NB
 OS10ES	 OS10WP
 OS10SB	 OS10WW
	 OS10WE

RÁMIK SOFT 1/2M

- dekoratívny rámik SOFT 1/2M
- vyhovuje EN 60669-1

COVER PLATE SOFT 1/2M
- decorative cover plate SOFT 1/2M
- in accordance with EN 60669-1



 OS13PW	 OS13SG
 OS13IW	 OS13NB
 OS13ES	 OS13WP
 OS13SB	 OS13WW
	 OS13WE

RÁMIK SOFT 1/3M

- dekoratívny rámik SOFT 1/3M
- vyhovuje EN 60669-1

COVER PLATE SOFT 1/3M
- decorative cover plate SOFT 1/3M
- in accordance with EN 60669-1



 OS23PW	 OS23SG
 OS23IW	 OS23NB
 OS23ES	 OS23WP
 OS23SB	 OS23WW
	 OS23WE

RÁMIK SOFT 2/3M

- dekoratívny rámik SOFT 2/3M
- vyhovuje EN 60669-1

COVER PLATE SOFT 2/3M
- decorative cover plate SOFT 2/3M
- in accordance with EN 60669-1

LASEROVÁ POTLAČ NA RÁMIKY



- laserová potlač ľubovoľných symbolov
- výroba na objednávku
- vhodné pre rámičky OL, OS

LASER PRINT ON COVER PLATES

- *laser print of any graphics*
- *made on request*
- *suitable for cover plates OL, OS*

DEKORÁCIE RÁMIKOV









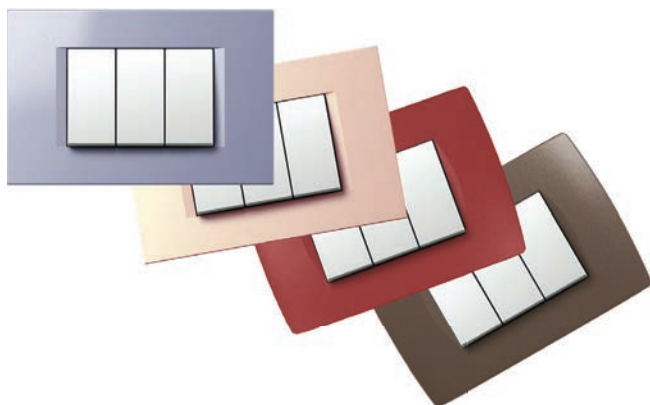

- vzorky a farby podľa výberu
- výroba na objednávku
- vhodné pre rámičky OL, OS

COVER PLATES DECORATIONS

- *customised textures and colours*
- *made on request*
- *suitable for cover plates OL, OS*

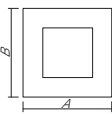
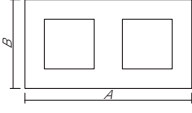
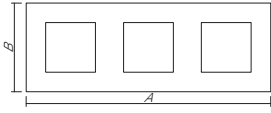
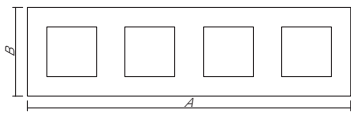

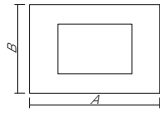
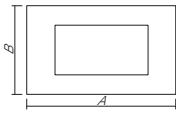
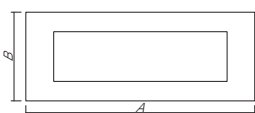
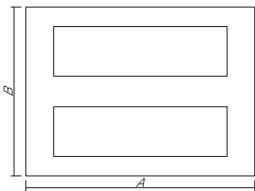
R Á M I K Y

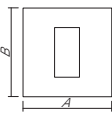
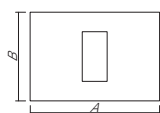
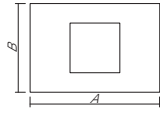
	 line A x B	 soft A x B	 PURE A x B
2M 	80 x 80 mm	84 x 84 mm	93 x 90 mm
2x2M 	151 x 80 mm	155 x 84 mm	164 x 90 mm
3x2M 	222 x 80 mm	226 x 84 mm	235 x 90 mm
4x2M 	293 x 80 mm	297 x 84 mm	
 3M 	122 x 80 mm	122 x 84 mm	134 x 90 mm
4M 	149 x 80 mm	144 x 84 mm	157 x 90 mm
7M 	207 x 80 mm	212 x 84 mm	224 x 90 mm
2x7M 		212 x 158 mm	
 1/2M 	80 x 80 mm	84 x 84 mm	
1/3M 	122 x 80 mm	122 x 84 mm	134 x 90 mm
2/3M 	122 x 80 mm	122 x 84 mm	134 x 90 mm

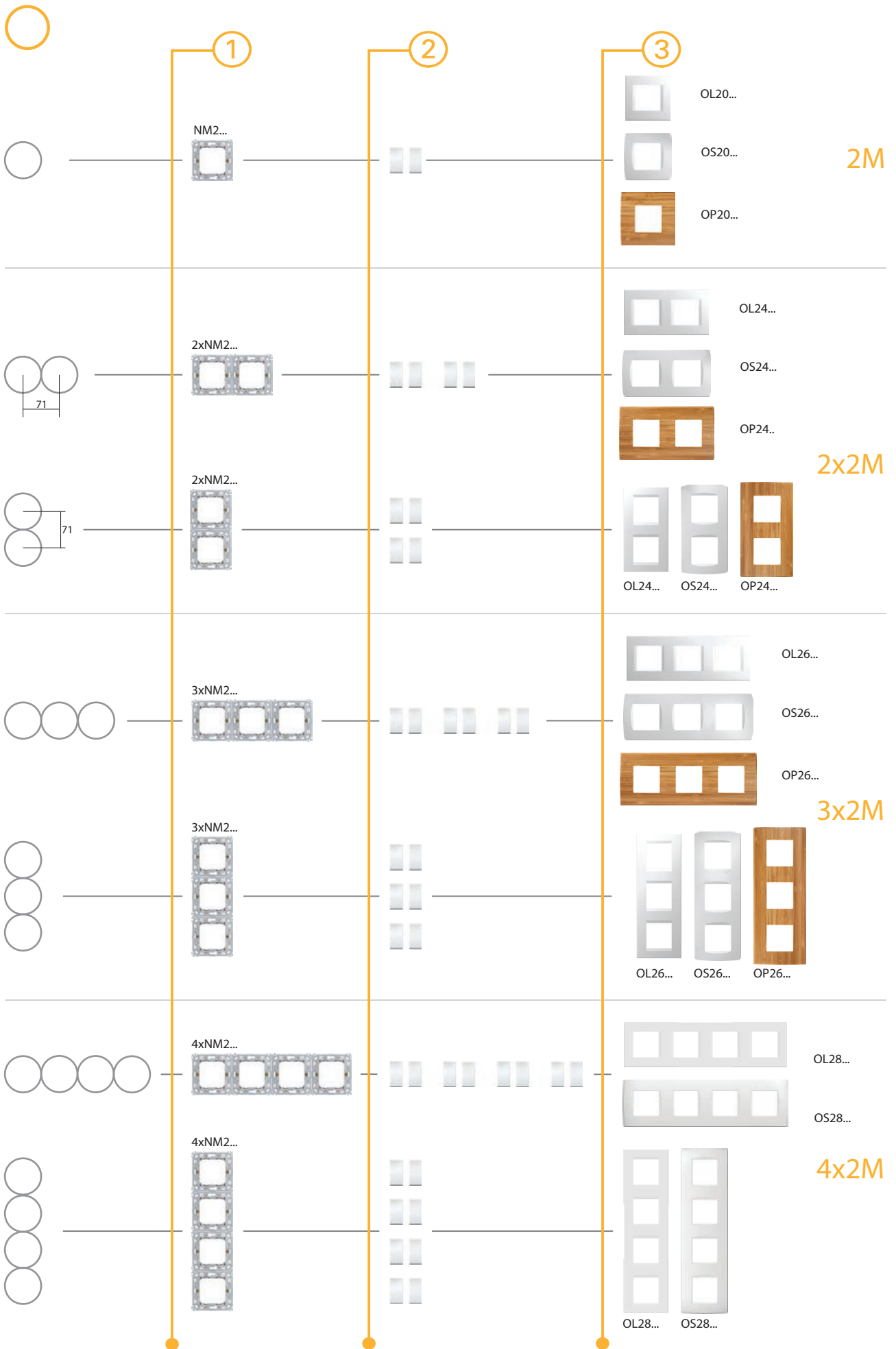

C O M B I N A T I O N S

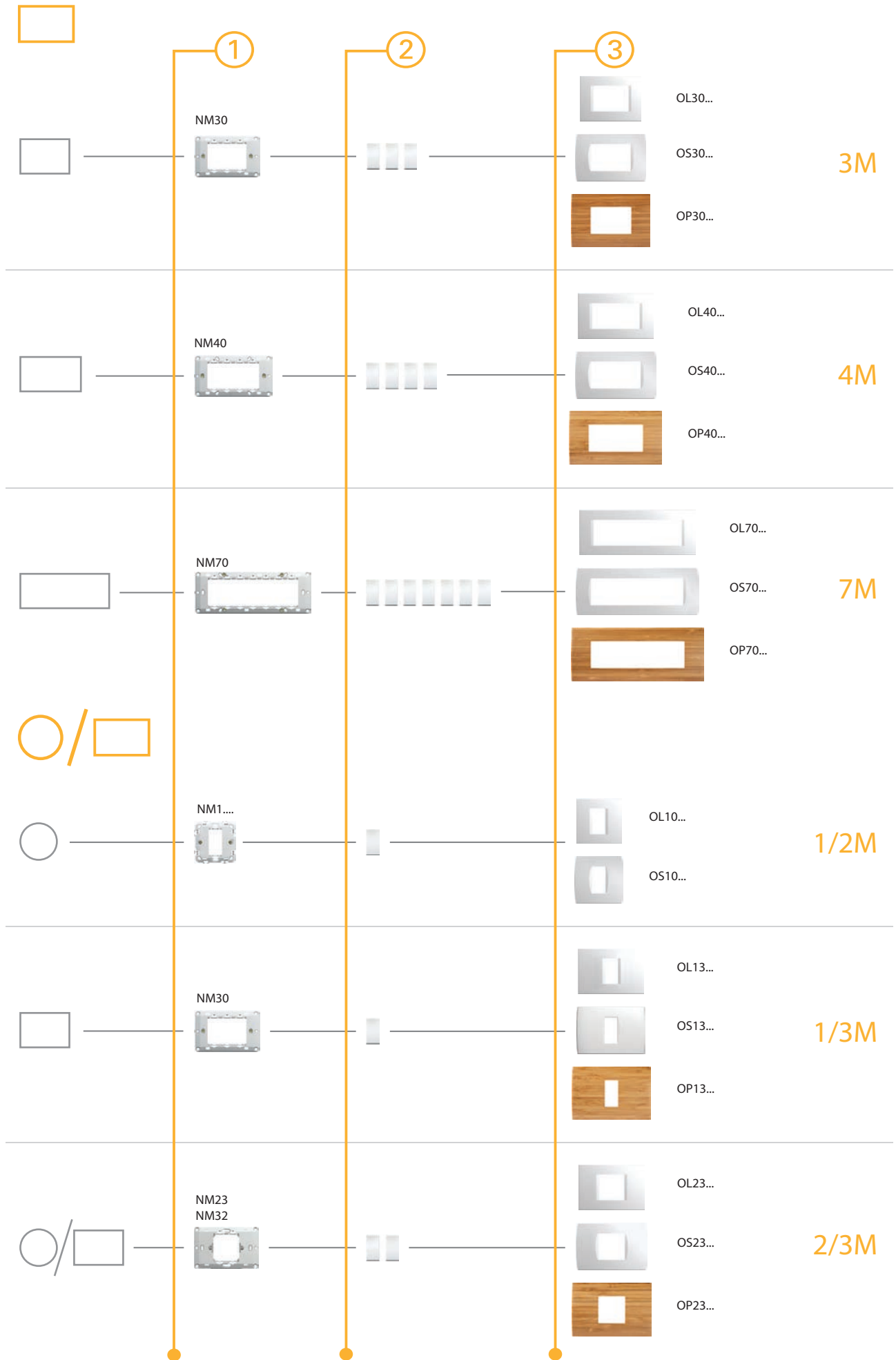



NM30

Typ type	názov description	veľkosť size
NM10	MONTÁŽNY RÁMIK SO SVORKAMI MOUNTING FRAME WITH CLAWS	1/2M
NM11	MONTÁŽNY RÁMIK BEZ SKRUTIEK MOUNTING FRAME WITHOUT SCREWS	1/2M
NM20	MONTÁŽNY RÁMIK SO SVORKAMI MOUNTING FRAME WITH CLAWS	2M
.	.	.
.	.	.



MONTÁŽNY RÁMIK SO SVORKAMI 2M

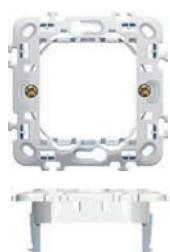

NM20

- montážny rámik 2M so svorkami
- montáž do krabíc Ø60 (DE..) svorkami
- možné horizontálne alebo vertikálne kombinovanie 2x2M, 3x2M a 4x2M
- vhodná na montáž s rámikmi LINE a SOFT
- vyhovuje EN 60669-1

MOUNTING FRAME WITH CLAWS 2M

- mounting frame 2M with claws
- for mounting on boxes Ø60 (DE..) with claws
- possible horizontal or vertical combinations 2x2M, 3x2M and 4x2M
- suitable for assembling with cover plates LINE and SOFT
- in accordance with EN 60669-1

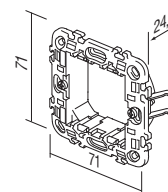

MONTÁŽNY RÁMIK BEZ SKRUTIEK 2M



NM21

- montážny rámik 2M bez skrutiek a bez svoriek
- montáž do krabíc Ø60 (HE.., BE..) skrutkami
- možné horizontálne alebo vertikálne kombinovanie 2x2M, 3x2M a 4x2M
- vhodná na montáž s rámikmi LINE a SOFT
- vyhovuje EN 60669-1

MOUNTING FRAME WITHOUT SCREWS 2M

- mounting frame 2M without screws and without claws
- for mounting on boxes Ø60 (HE.., BE..) with screws
- possible horizontal or vertical combinations 2x2M, 3x2M and 4x2M
- suitable for assembling with cover plates LINE and SOFT
- in accordance with EN 60669-1

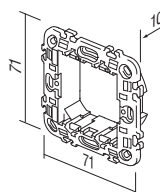

MONTÁŽNY RÁMIK KOVOVÝ SO SVORKAMI 2M

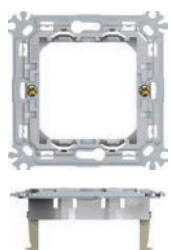

NM24

- kovový montážny rámik 2M so svorkami - neohybné prevedenie
- montáž do krabíc Ø60 (DE..) svorkami
- možné horizontálne alebo vertikálne kombinovanie 2x2M, 3x2M a 4x2M
- vhodná na montáž s rámikmi PURE, LINE a SOFT
- vyhovuje EN 60669-1

MOUNTING FRAME METAL WITH CLAWS 2M

- metal mounting frame 2M with claws - stiff version
- for mounting on boxes Ø60 (DE..) with claws
- possible horizontal or vertical combinations 2x2M, 3x2M and 4x2M
- suitable for assembling with cover plates PURE, LINE and SOFT
- in accordance with EN 60669-1

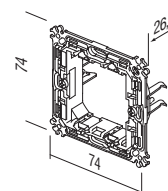

MONTÁŽNY RÁMIK KOVOVÝ BEZ SKRUTIEK 2M



NM25

- kovový montážny rámik bez skrutiek a bez svoriek - neohybné prevedenie
- montáž do krabíc Ø60 (HE.., BE..) svorkami
- možné horizontálne alebo vertikálne kombinovanie 2x2M, 3x2M a 4x2M
- vhodná na montáž s rámikmi PURE, LINE a SOFT
- vyhovuje EN 60669-1

MOUNTING FRAME METAL WITHOUT SCREWS 2M

- metal mounting frame 2M without screws and without claws - stiff version
- for mounting on boxes Ø60 (HE.., BE..) with claws
- possible horizontal or vertical combinations 2x2M, 3x2M and 4x2M
- suitable for assembling with cover plates PURE, LINE and SOFT
- in accordance with EN 60669-1

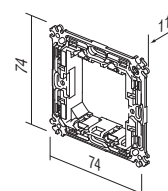

M O U N T I N G F R A M E S N M



NM30

MONTÁŽNY RÁMIK SO SKRUTKAMI 3M

- montážny rámik 3M so skrutkami
- montáž do obdĺžnikových krabíc veľkosti 3M
- vhodná na montáž s rámikmi PURE, LINE a SOFT
- vyhovuje EN 60669-1

MOUNTING FRAME WITH SCREWS 3M

- mounting frame 3M with screws
- for mounting on rectangular boxes 3M
- suitable for assembling with cover plates PURE, LINE and SOFT
- in accordance with EN 60669-1

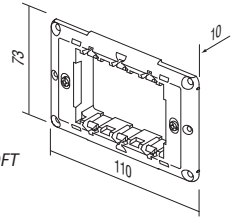

NM40

MONTÁŽNY RÁMIK SO SKRUTKAMI 4M

- montážny rámik 4M so skrutkami
- montáž do obdĺžnikových krabíc veľkosti 3M
- vhodná na montáž s rámikmi PURE, LINE a SOFT
- vyhovuje EN 60669-1

MOUNTING FRAME WITH SCREWS 4M

- mounting frame 4M with screws
- for mounting on rectangular boxes 4M
- suitable for assembling with cover plates PURE, LINE and SOFT
- in accordance with EN 60669-1

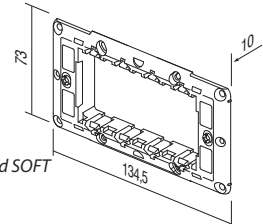

NM70

MONTÁŽNY RÁMIK SO SKRUTKAMI 7M

- montážny rámik 7M so skrutkami
- montáž do obdĺžnikových krabíc veľkosti 3M
- vhodná na montáž s rámikmi PURE, LINE a SOFT
- vyhovuje EN 60669-1

MOUNTING FRAME WITH SCREWS 7M

- mounting frame 7M with screws
- for mounting on rectangular boxes 7M
- suitable for assembling with cover plates PURE, LINE and SOFT
- in accordance with EN 60669-1

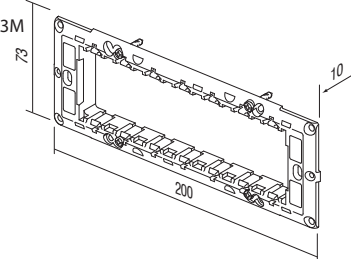

NM72

MONTÁŽNY RÁMIK SO SKRUTKAMI 2X7M

- montážny rámik 2x7M so skrutkami
- inštalácia do obdĺžnikových krabíc rozmerov 2x7M
- vhodná pre zloženie s rámikom SOFT OS72
- vyhovuje EN 60669-1

MOUNTING FRAME WITH

SCREWS 2x7M

- mounting frame 2x7M with screws
- for mounting on rectangular boxes 2x7M
- suitable for assembling with cover plate SOFT OS72
- in accordance with EN 60669-1

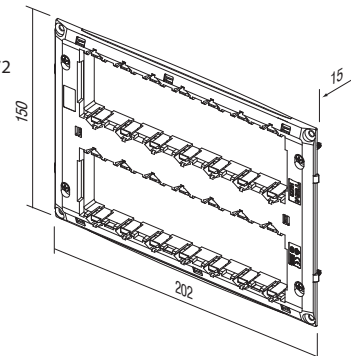



NM10

MONTÁŽNY RÁMIK SO SVORKAMI 1/2M

- montážny rámik 1/2M so svorkami
- montáž do krabíc Ø60 (DE..) svorkami
- vhodná na montáž s rámikmi LINE a SOFT
- vyhovuje EN 60669-1

MOUNTING FRAME WITH CLAWS 1/2M

- mounting frame 1/2M with claws
- for mounting on boxes Ø60 (DE..) with claws
- suitable for assembling with cover plates LINE and SOFT
- in accordance with EN 60669-1

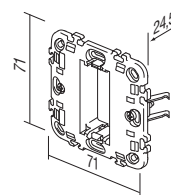

NM11

MONTÁŽNY RÁMIK BEZ SKRUTIEK 1/2M

- montážny rámik 1/2M bez skrutiek a bez svoriek
- montáž do krabíc Ø60 (HE., BE..) skrutkami
- vhodná na montáž s rámikmi LINE a SOFT
- vyhovuje EN 60669-1

MOUNTING FRAME WITHOUT SCREWS 1/2M

- mounting frame 1/2M without screws and without claws
- for mounting on boxes Ø60 (HE., BE..) with screws
- suitable for assembling with cover plates LINE and SOFT
- in accordance with EN 60669-1

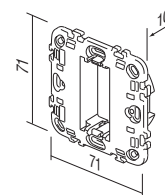

NM23

MONTÁŽNY RÁMIK SO SVORKAMI 2/3M

- montážny rámik 2/3M so svorkami
- montáž do krabíc Ø60 (DE..) svorkami
- vhodná na montáž s rámikmi PURE, LINE a SOFT
- vyhovuje EN 60669-1

MOUNTING FRAME WITH CLAWS 2/3M

- mounting frame 2/3M with claws
- for mounting on boxes Ø60 (DE..) with claws
- suitable for assembling with cover plates PURE, LINE and SOFT
- in accordance with EN 60669-1

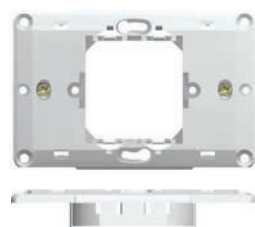
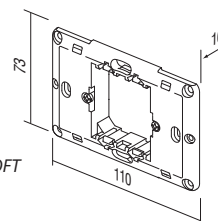

NM32

MONTÁŽNY RÁMIK SO SKRUTKAMI 2/3M

- montážny rámik 2/3M so skrutkami
- montáž do obdĺžnikových krabíc veľkosti 3M
- vhodná na montáž s rámikmi PURE, LINE a SOFT
- vyhovuje EN 60669-1

MOUNTING FRAME WITH SCREWS 2/3M

- mounting frame 2/3M with screws
- for mounting on rectangular boxes 3M
- suitable for assembling with cover plates PURE, LINE and SOFT
- in accordance with EN 60669-1

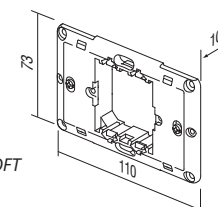

TEM

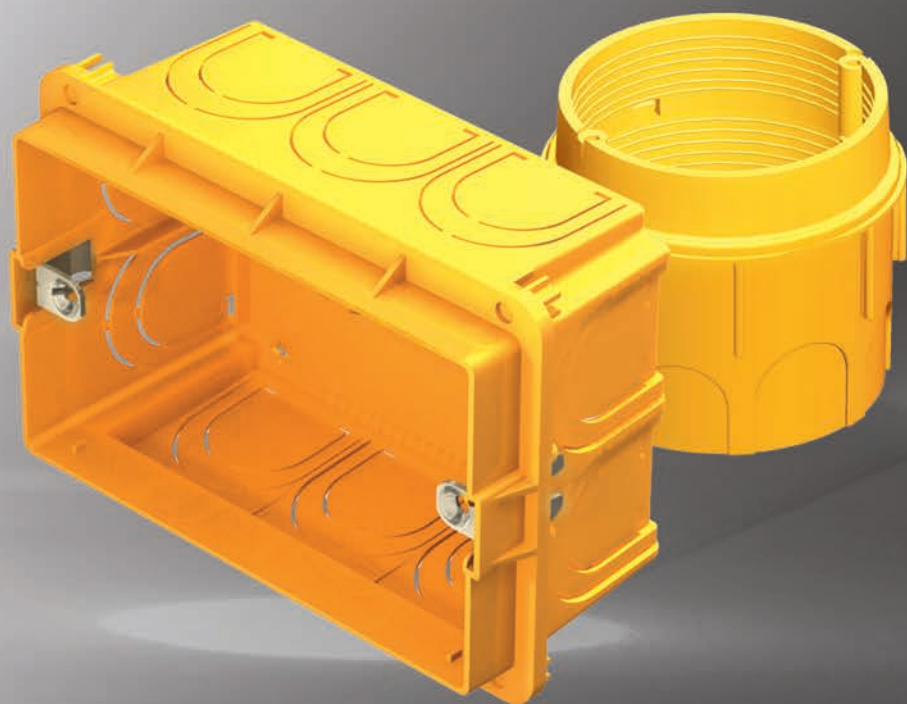

KATALOG / CATALOGUE

KRABICE



OKRÚHLE KRABICE
ROUND BOXES



118

OBĎŹNIKOVÉ KRABICE
RECTANGULAR BOXES



126

ROZVODNÉ KRABICE
JUNCTION BOXES



134

PRÍSLUŠENSTVO PRE ELEKTRICKÉ INŠTALÁCIE
WIRING ACCESSORIES



136

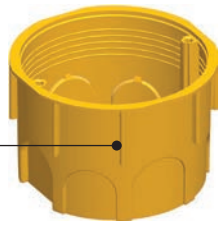

DE12



HE11

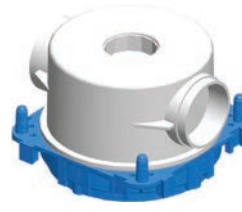

BE10

Typ type	názov description	veľkosť size
DE10	KRABICA OKRÚHLA DO STENY ROUND BOX BRICK	SM60-01
HE10	KRABICA OKRÚHLA PRE DUTÉ STENY ROUND BOX HOLLOW WALL	SM68X40
BE10	KRABICA OKRÚHLA DO BETÓNU ROUND BOX CONCRETE	
.	.	.
.	.	.

KRABICA OKRÚHLA DO STENY SM60-01



DE10

- Ø60, hĺbka 40 mm
- 650°C, 500V~
- vyhovuje IEC 60670-1
- bezhalogénový

ROUND BOX BRICK SM60-01

- Ø60, depth 40mm
- 650°C, 500V~
- in accordance with IEC 60670-1
- halogen free

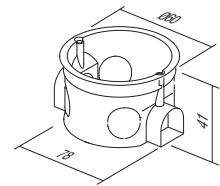

KRABICA OKRÚHLA DO STENY HLBOKÁ SM60-06



DE11

- Ø60, hĺbka 60 mm
- 650°C, 500V~
- vyhovuje IEC 60670-1
- bezhalogénový

ROUND BOX BRICK DEEP SM60-06

- Ø60, depth 60mm
- 650°C, 500V~
- in accordance with IEC 60670-1
- halogen free

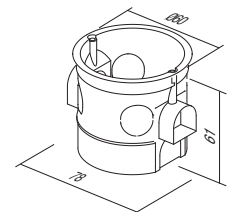

SPOJOVACÍ ČLÁNOK NA KRABICE DO STENY SM60-03



DE30

- na vertikálne spojenie krabíc SM60-06 alebo SM60-01 na vzdialenosť 91mm
- vyhovuje IEC 60670-1
- bezhalogénový

COMBI-CLIP SM60-03

- for vertical fitting of boxes SM60-06 or SM60-01 on distance 91 mm
- in accordance with IEC 60670-1
- halogen free

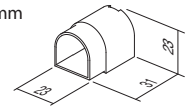

SPOJOVACÍ ČLÁNOK NA KRABICE DO STENY SM60-04











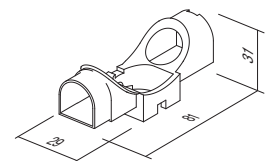



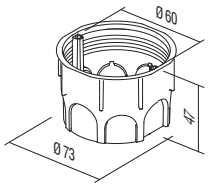
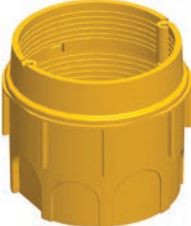
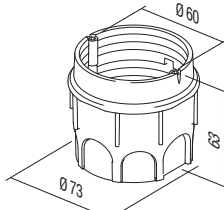

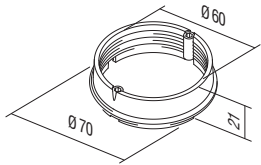
DE31

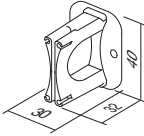
- na horizontálne spojenie krabíc SM60-06 alebo SM60-01 na vzdialenosť 71mm
- vyhovuje IEC 60670-1
- bezhalogénový

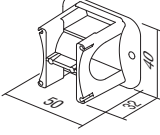
COMBI-CLIP SM60-04

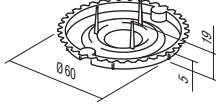
- for horizontal fitting of boxes SM60-06 or SM60-01 on distance 71mm
- in accordance with IEC 60670-1
- halogen free

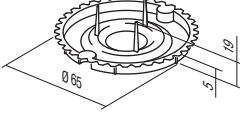

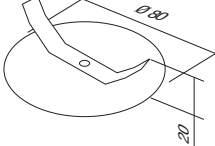
	DE12	KRABICA OKRÚHLA DO STENY MD65-46 - Ø65, hĺbka 46 mm - 650°C, 500V~ - vyhovuje IEC 60670-1 <i>ROUND BOX BRICK MD65-46</i> - Ø65, depth 46mm - 650°C, 500V~ - in accordance with IEC 60670-1	
	DE13	KRABICA OKRÚHLA DO STENY HLBOKÁ MD65-60 - Ø65/60, hĺbka 62 mm - 650°C, 500V~ - vyhovuje IEC 60670-1 <i>ROUND BOX BRICK DEEP MD65-60</i> - Ø65/60, depth 62mm - 650°C, 500V~ - in accordance with IEC 60670-1	
	DE14	PREDĹŽENIE KRABICE DO STENY MD65-46 - Ø65/60, hĺbka 17 mm - 650°C, 500V~ - vyhovuje IEC 60670-1 <i>ADDITIONAL PIECE FOR MD65-46</i> - Ø65/60, depth 17mm - 650°C, 500V~ - in accordance with IEC 60670-1	
	DE32	SPOJOVACÍ ČLÁNOK NA KRABICE DO STENY MD65-71 - na spojenie krabic MD65 na vzdialenosť 71 mm - vyhovuje IEC 60670-1 <i>COMBI-CLIP MD65-71</i> - for fitting of boxes MD65 on distance 71 mm - in accordance with IEC 60670-1	
	DE33	SPOJOVACÍ ČLÁNOK NA KRABICE DO STENY MD65-91 - na spojenie krabic MD65 na vzdialenosť 91 mm - vyhovuje IEC 60670-1 <i>COMBI-CLIP MD65-91</i> - for fitting of boxes MD65 on distance 91 mm - in accordance with IEC 60670-1	
	DE20	KRYT KRABICE OCHRANNÝ 60 - ochranný kryt krabice Ø60 pre DE13, DE14 - vyhovuje IEC 60670-1 - na ochranu pri omietaní <i>BOX COVER PROTECTIVE 60</i> - protective cover for box Ø60 for DE13, DE14 - in accordance with IEC 60670-1 - box protection during plastering	
	DE21	KRYT KRABICE OCHRANNÝ 65 - ochranný kryt krabice Ø65 pre DE12 - vyhovuje IEC 60670-1 - na ochranu pri omietaní <i>BOX COVER PROTECTIVE 65</i> - protective cover for box Ø65 for DE12 - in accordance with IEC 60670-1 - box protection during plastering	
	DE22	KRYT KRABICE DEKORATÍVNY SM60 - dekoratívny kryt krabice Ø60 - vyhovuje IEC 60670-1 - bezhalogénový <i>BOX COVER DECORATIVE SM60</i> - decorative cover for boxes Ø60 - in accordance with IEC 60670-1 - halogen free	



návod na montáž /
assembly instructions

vzdialenosť medzi krabicami /
distance between boxes: 71mm

vzdialenosť medzi krabicami /
distance between boxes: 91mm

DE10,11

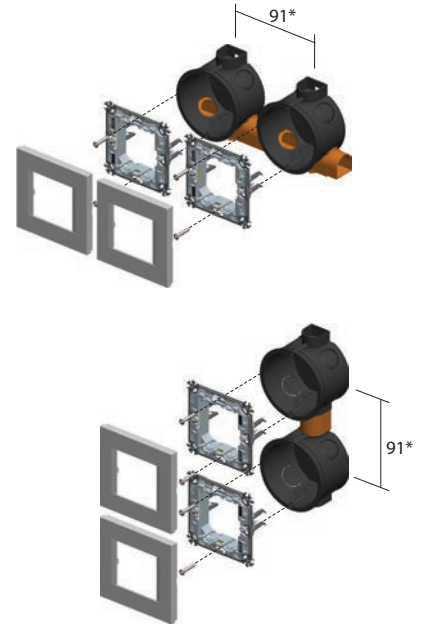
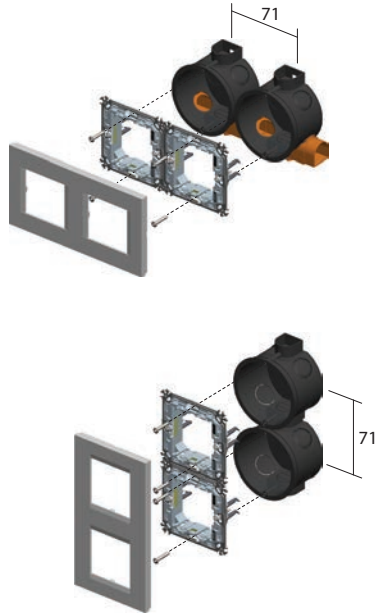

DE12,13

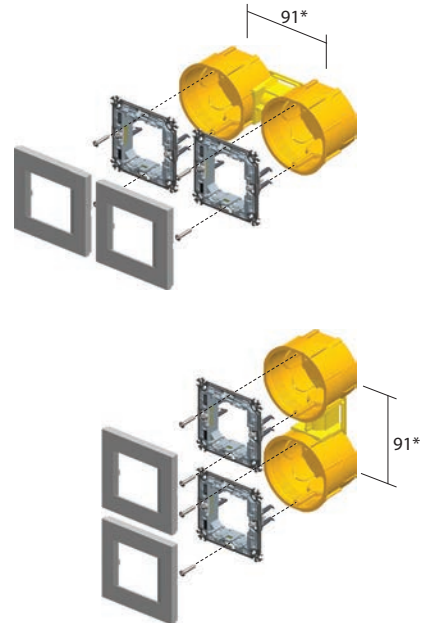
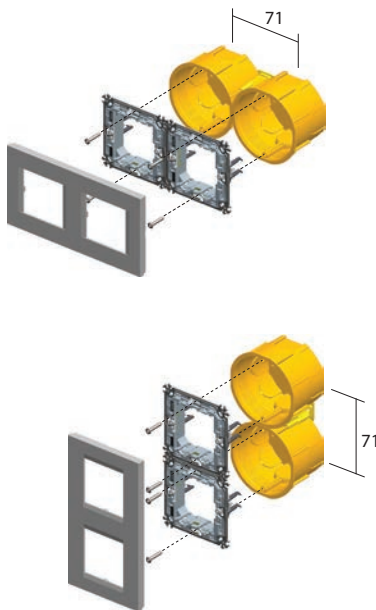
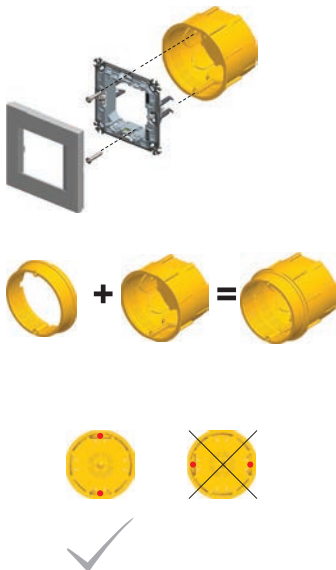

* pri rámkoch PURE je minimálna vzdialenosť medzi krabicami 100 mm

* for PURE cover plates the minimum distance between boxes is 100mm

R O U N D B O X E S



DE10,11



DE12,13



NM20



NM24



DE10,11



DE12,13



NM10



DE10,11



DE12,13



NM23



71

2xDE10,11 + 2xDE31



2xDE12,13 + 1xDE32



2xNM20



2xNM24



2xDE10,11 2xDE12,13 + 1xDE32



2xNM20



2xNM24



3xDE10,11 + 3xDE31



3xDE12,13 + 2xDE32



3xNM20



3xNM24



3xDE10,11 3xDE12,13 + 2xDE32

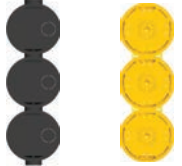

3xNM20



3xNM24



4xDE10,11 + 4xDE31



4xDE12,13 + 3xDE32



4xNM20



4xNM24

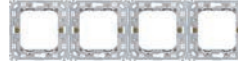

4xDE10,11 4xDE12,13 + 3xDE32

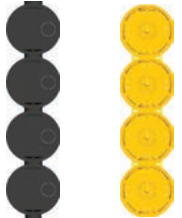

4xNM20



4xNM24



KRABICA OKRÚHLA PRE DUTÉ STENY SM68x40



HE10

- Ø60, hĺbka 40 mm
- montáž do otvoru Ø68
- 850°C, 400V~
- vyhovuje IEC 60670-1
- montáž svorkami
- bezhalogénový

ROUND BOX HOLLOW WALL SM68x40

- Ø60, depth 40mm
- cutting hole Ø68
- 850°C, 400V~
- in accordance with IEC 60670-1
- mounting with claws
- halogen free

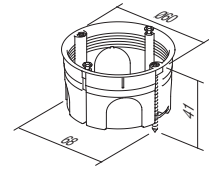

KRABICA OKRÚHLA PRE DUTÉ STENY SM68x55



HE11

- Ø60, hĺbka 55 mm
- montáž do otvoru Ø68
- 850°C, 400V~
- vyhovuje IEC 60670-1
- montáž svorkami
- bezhalogénový

ROUND BOX HOLLOW WALL SM68x55

- Ø60, depth 55mm
- cutting hole Ø68
- 850°C, 400V~
- in accordance with IEC 60670-1
- mounting with claws
- halogen free

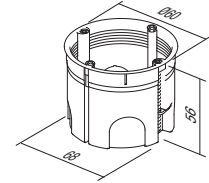

KRABICA OKRÚHLA DO BETÓNU

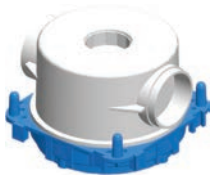

BE10

- Ø60 mm, hĺbka 49 mm
- 650°C, 500V~
- vyhovuje IEC 60670-1

ROUND BOX CONCRETE

- Ø60mm, depth 49mm
- 650°C, 500V~
- in accordance with IEC 60670-1

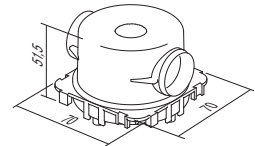

KRABICA OKRÚHLA DO BETÓNU HLBOKÁ



BE11

- Ø60 mm, hĺbka 58 mm
- 650°C, 500V~
- vyhovuje IEC 60670-1

ROUND BOX CONCRETE DEEP

- Ø60mm, depth 58mm
- 650°C, 500V~
- in accordance with IEC 60670-1

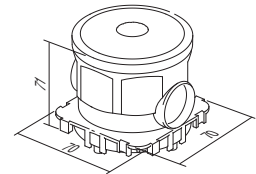

MONTÁŽNY RÁMIK KRABICE DO BETÓNU



BE20

- na upevnenie krabice s dištančným profilom BM82 do protiľahlej steny
- vyhovuje IEC 60670-1

COUNTER BOX SUPPORT CONCRETE

- to support concrete boxes with distance profile BM82 for extreme loads
- in accordance with IEC 60670-1

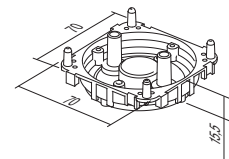

PRIECHODKA KRABICE DO BETÓNU 16



BE21

- na upevnenie inštaláčnej trubice
- vyhovuje IEC 60670-1

PIPE STOPPER CONCRETE BOX 16

- for firming installation pipe to box
- in accordance with IEC 60670-1

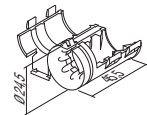

R O U N D B O X E S

duté steny / hollow walls



betón / concrete



návod na montáž /
assembly instructions

vzdialenosť medzi krabicami /
distance between boxes: 71mm

vzdialenosť medzi krabicami /
distance between boxes: 91mm

HE10,11

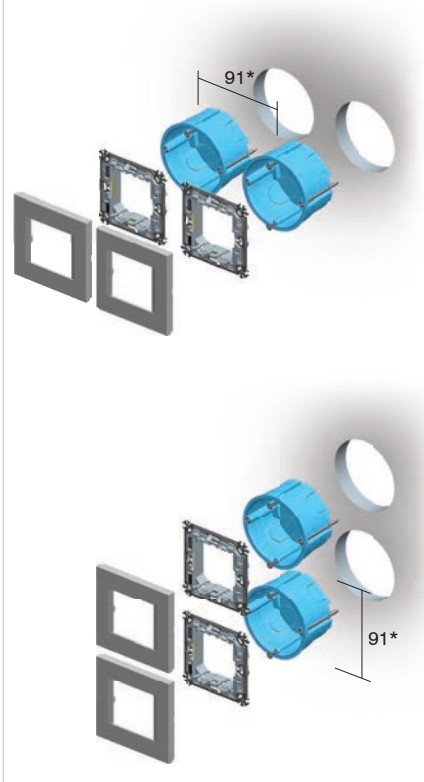
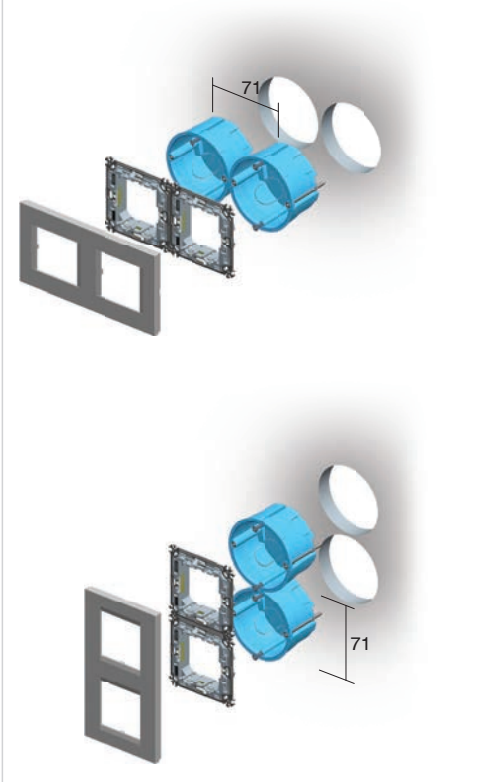
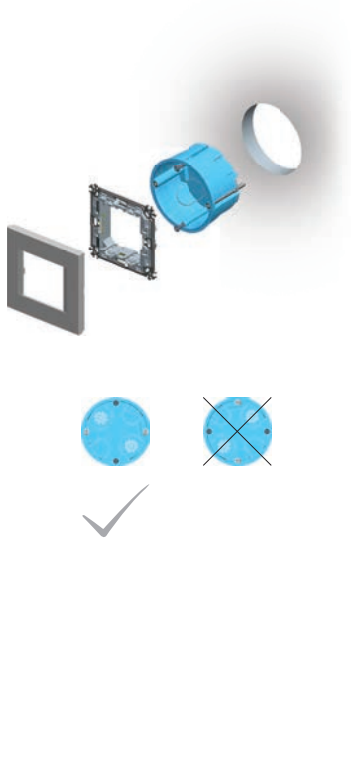

BE10

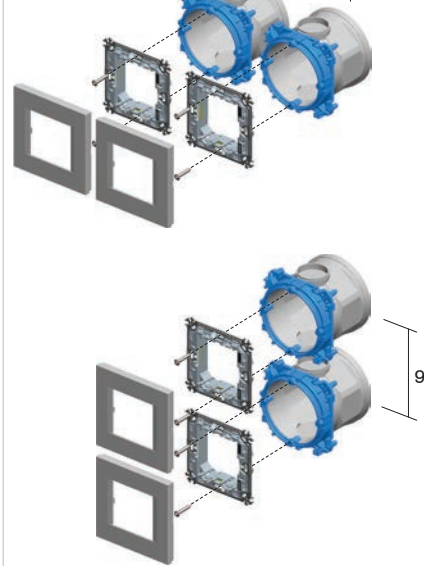
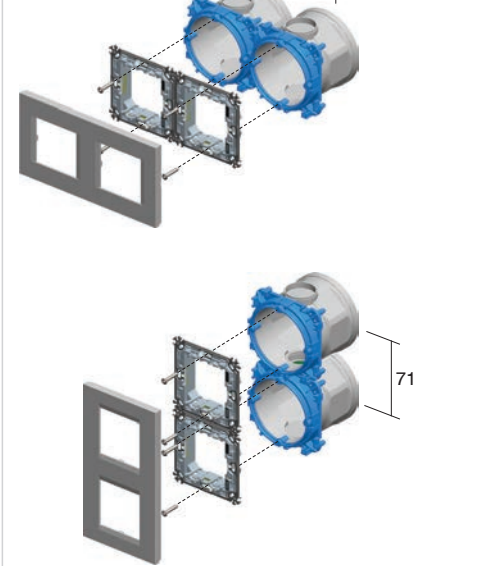
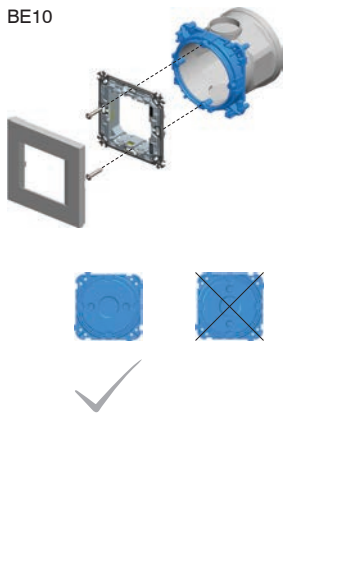

* pri rámkoch PURE je minimálna vzdialenosť medzi krabicami 100 mm

* for PURE cover plates the minimum distance between boxes is 100mm

duté stěny / hollow walls



betón / concrete



HE10,11



BE10,11



NM21



NM25



2M

HE10,11



BE10,11



NM11



1/2M

2xHE10,11



2xBE10,11



2xNM21



2xNM25



2x2M

HE10,11



BE10,11



NM32



2/3M

2xHE10,11



2xBE10,11



2xNM21



2xNM25



3xHE10,11



3xBE10,11



3xNM21



3xNM25



3x2M

3xHE10,11



3xBE10,11



3xNM21



3xNM25



4xHE10,11



4xBE10,11



4xNM21



4xNM25



4x2M

4xHE10,11



4xBE10,11



4xNM21



4xNM25



R O U N D B O X E S



návod na montáž /
assembly instructions

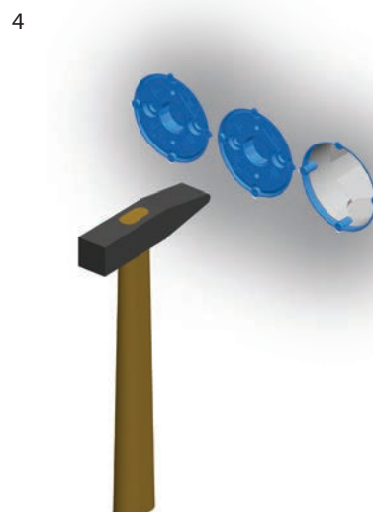
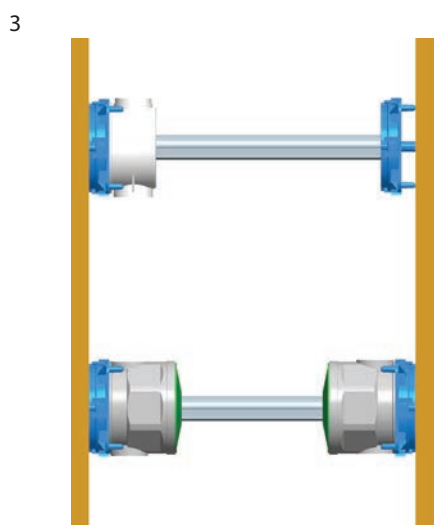
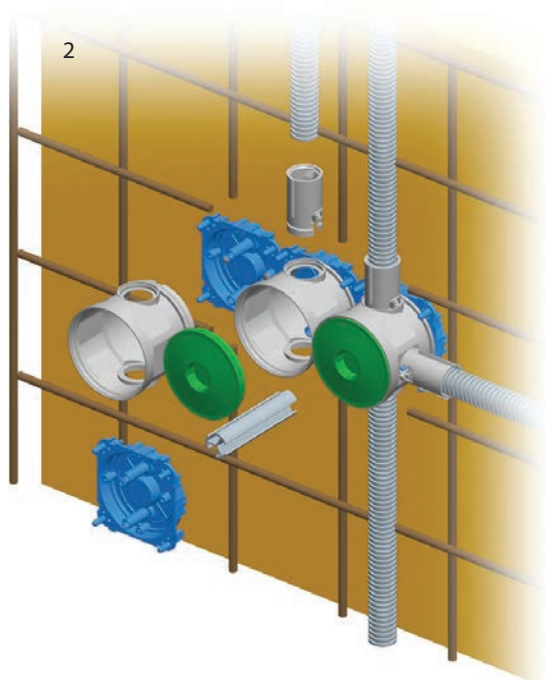
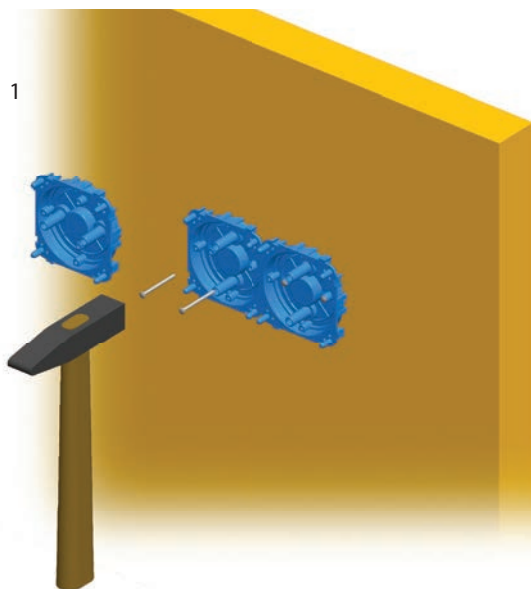

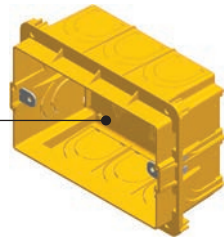

DM30



HM30

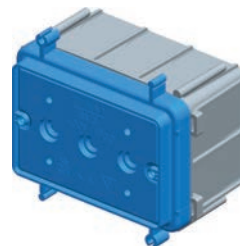

BM30

Typ type	název description	velikost size
DM30	KRABICA OBDĚLNÍKOVÁ DO STĚNY RECTANGULAR BOX BRICK	PM3
HM30	KRABICA OBDĚLNÍKOVÁ PRE DUTÉ STĚNY RECTANGULAR BOX HOLLOW WALL	VM3
BM30	KRABICA OBDĚLNÍKOVÁ DO BETÓNU RECTANGULAR BOX CONCRETE	BM3
.	.	.
.	.	.

KRABICA OBDĚLNÍKOVÁ DO STĚNY PM3



DM30

- velikost 3M, hloubka 49 mm
- 650°C, 400V~
- vyhovuje IEC 60670-1
- bezhalogénový

RECTANGULAR BOX BRICK PM3

- size 3M, depth 49mm
- 650°C, 400V~
- in accordance with IEC 60670-1
- halogen free

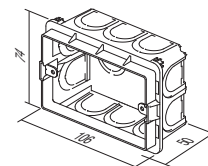

KRABICA OBDĚLNÍKOVÁ DO STĚNY PM3-65



DM31

- velikost 3M, hloubka 65 mm
- 650°C, 400V~
- vyhovuje IEC 60670-1
- bezhalogénový

RECTANGULAR BOX BRICK PM3-65

- size 3M, depth 65mm
- 650°C, 400V~
- in accordance with IEC 60670-1
- halogen free

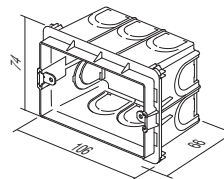

KRABICA OBDĚLNÍKOVÁ DO STĚNY PM4



DM40

- velikost 4M, hloubka 49 mm
- 650°C, 400V~
- vyhovuje IEC 60670-1
- bezhalogénový

RECTANGULAR BOX BRICK PM4

- size 4M, depth 49mm
- 650°C, 400V~
- in accordance with IEC 60670-1
- halogen free

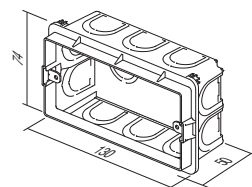

KRABICA OBDĚLNÍKOVÁ DO STĚNY PM4-65



DM41

- velikost 4M, hloubka 65 mm
- 650°C, 400V~
- vyhovuje IEC 60670-1
- bezhalogénový

RECTANGULAR BOX BRICK PM4-65

- size 4M, depth 65mm
- 650°C, 400V~
- in accordance with IEC 60670-1
- halogen free

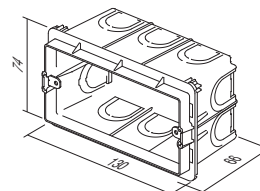

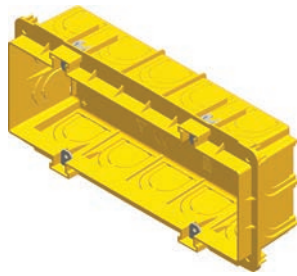

DM70

KRABICA OBDĚLNÍKOVÁ DO STENY PM7

- veľkosť 7M, hĺbka 49 mm
- 650°C, 400V~
- vyhovuje IEC 60670-1
- bezhalogénový

RECTANGULAR BOX BRICK PM7

- size 7M, depth 49mm
- 650°C, 400V~
- in accordance with IEC 60670-1
- halogen free

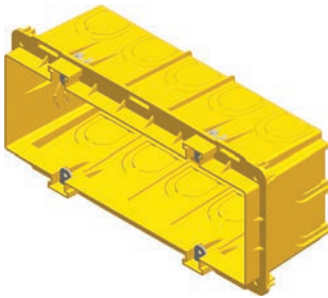
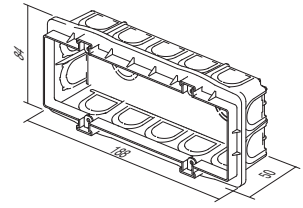

DM71

KRABICA OBDĚLNÍKOVÁ DO STENY PM7-65

- veľkosť 7M, hĺbka 65 mm
- 650°C, 400V~
- vyhovuje IEC 60670-1
- bezhalogénový

RECTANGULAR BOX BRICK PM7-65

- size 7M, depth 65mm
- 650°C, 400V~
- in accordance with IEC 60670-1
- halogen free

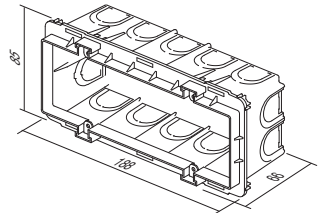

DM72

KRABICA OBDĚLNÍKOVÁ DO STENY PM72-65

- rozmery 2x7M, hĺbka 64 mm
- 650°C, 400 V ~
- vyhovuje IEC 60670-1

RECTANGULAR BOX BRICK PM72-65

- size 2x7M, depth 64mm
- 650°C, 400V~
- in accordance with IEC 60670-1

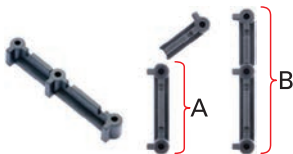
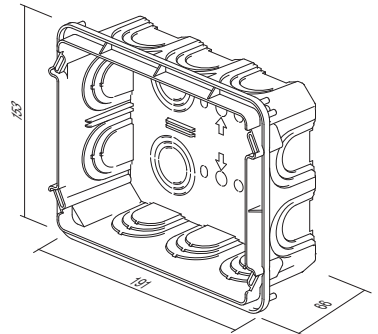

DM80

SPOJOVACÍ ČLÁNEK NA KRABICE PM

- na vertikálnu (B) a horizontálnu (A) montáž krabic PM3, PM4 a PM7

DISTANCE PIECE FOR BOX PM

- for vertical (B) and horizontal (A) fitting of boxes PM3, PM4 and PM7

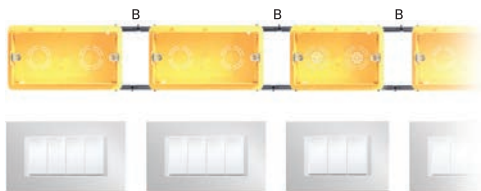
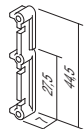



DM33

KRYT KRABICE OCHRANNÝ PM3

- ochranný kryt krabice PM3
- vyhovuje IEC 60670-1
- bezhalogénový
- na ochranu pri omietaní

BOX COVER PROTECTIVE PM3
 - protective cover for box PM3
 - in accordance with IEC 60670-1
 - halogen free
 - box protection during plastering

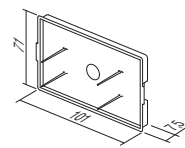

DM34

KRYT KRABICE DEKORATÍVNY PM3

- dekoratívny kryt krabice 3M
- skrutky priložené
- vyhovuje IEC 60670-1
- bezhalogénový

BOX COVER DECORATIVE PM3
 - decorative cover for boxes 3M
 - screws are included
 - in accordance with IEC 60670-1
 - halogen free

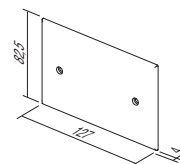

DM43

KRYT KRABICE OCHRANNÝ PM4

- ochranný kryt krabice PM4
- vyhovuje IEC 60670-1
- bezhalogénový
- na ochranu pri omietaní

BOX COVER PROTECTIVE PM4
 - protective cover for box PM4
 - in accordance with IEC 60670-1
 - halogen free
 - box protection during plastering

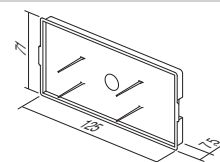

DM44

KRYT KRABICE DEKORATÍVNY PM4

- dekoratívny kryt krabice 4M
- skrutky priložené
- vyhovuje IEC 60670-1
- bezhalogénový

BOX COVER DECORATIVE PM4
 - decorative cover for boxes 4M
 - screws are included
 - in accordance with IEC 60670-1
 - halogen free

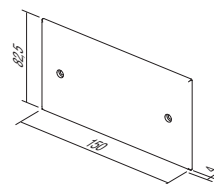

DM73

KRYT KRABICE OCHRANNÝ PM7

- ochranný kryt krabice PM7
- vyhovuje IEC 60670-1
- bezhalogénový
- na ochranu pri omietaní

BOX COVER PROTECTIVE PM7
 - protective cover for box PM7
 - in accordance with IEC 60670-1
 - halogen free
 - box protection during plastering

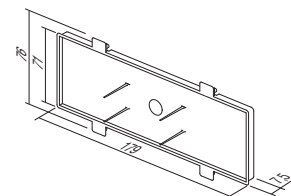

DM74

KRYT KRABICE DEKORATÍVNY PM7

- dekoratívny kryt krabice 7M
- skrutky priložené
- vyhovuje IEC 60670-1
- bezhalogénový

BOX COVER DECORATIVE PM7
 - decorative cover for boxes 7M
 - screws are included
 - in accordance with IEC 60670-1
 - halogen free

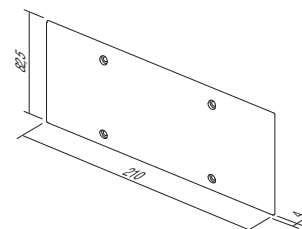



DM75

KRYT NA KRABICU DEKORATÍVNY PM72

- dekoratívny kryt na krabice 2x7M
- skrutky sú priložené
- vyhovuje IEC 60670-1

BOX COVER DECORATIVE PM72
- decorative cover for boxes 2x7M
- screws are included
- in accordance with IEC 60670-1

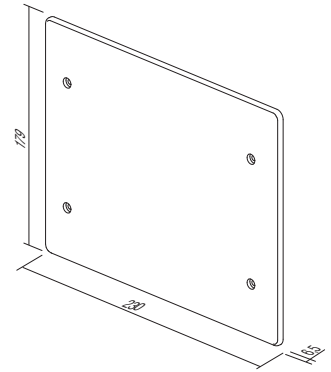



HM30

KRABICA OBDĚŢNIKOVÁ PRE DUTÉ STENY VM3

- veľkosť 3M, hĺbka 49 mm
- montáž do otvoru 2xØ68/45mm
- 850°C, 400V~
- vyhovuje IEC 60670-1
- bezhalogénový

RECTANGULAR BOX HOLLOW WALL VM3

- size 3M, depth 49mm
- cutting hole 2xØ68/45mm
- 850°C, 400V~
- in accordance with IEC 60670-1
- halogen free

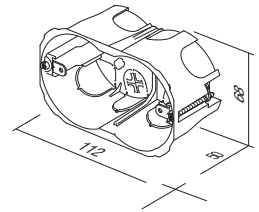

HM40

KRABICA OBDĚŢNIKOVÁ PRE DUTÉ STENY VM4

- veľkosť 4M, hĺbka 49 mm
- montáž do otvoru 2xØ68/70mm
- 850°C, 400V~
- vyhovuje IEC 60670-1
- bezhalogénový

RECTANGULAR BOX HOLLOW WALL VM4

- size 4M, depth 49mm
- cutting hole 2xØ68/70mm
- 850°C, 400V~
- in accordance with IEC 60670-1
- halogen free

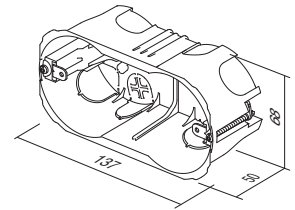

HM70

KRABICA OBDĚŢNIKOVÁ PRE DUTÉ STENY VM7

- veľkosť 7M, hĺbka 49 mm
- montáž do otvoru 2xØ68/120mm
- 850°C, 400V~
- vyhovuje IEC 60670-1
- bezhalogénový

RECTANGULAR BOX HOLLOW WALL VM7

- size 7M, depth 49mm
- cutting hole 2xØ68/120mm
- 850°C, 400V~
- in accordance with IEC 60670-1
- halogen free

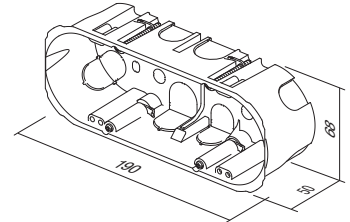

HM72



KRABICA OBDĚŢNIKOVÁ DO DUTÝCH STIEN VM72

- rozmery 2x7M, hĺbka 63 mm
- 850°C, 400 V ~
- vyhovuje IEC 60670-1

RECTANGULAR BOX HOLLOW WALL VM72

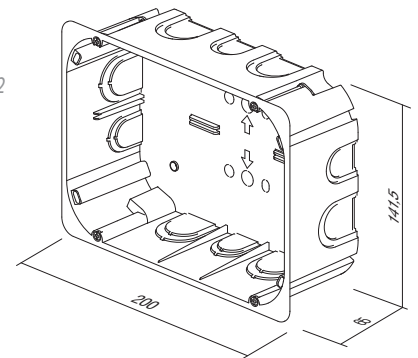
- size 2x7M, depth 63mm
- 850°C, 400V~
- in accordance with IEC 60670-1

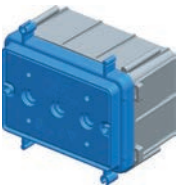
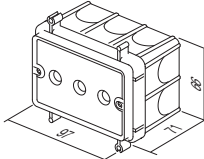
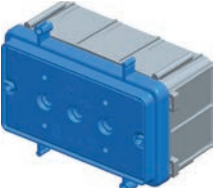
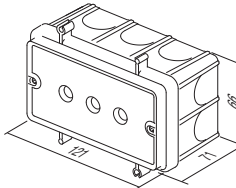
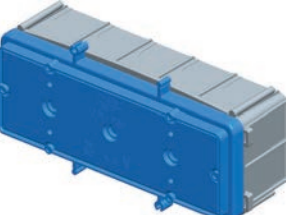
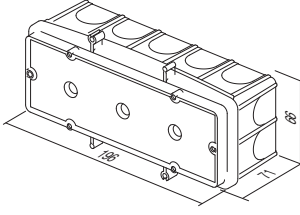

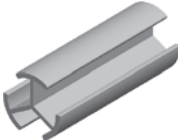
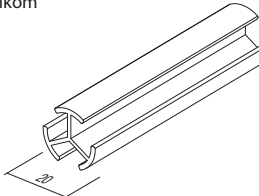
	BM30	<p>KRABICA OBDĹŽNIKOVÁ DO BETÓNU BM3</p> <ul style="list-style-type: none"> - veľkosť 3M, hĺbka 60 mm - 650°C, 400V~ - vyhovuje IEC 60670-1 <p><i>RECTANGULAR BOX CONCRETE BM3</i></p> <ul style="list-style-type: none"> - size 3M, depth 60mm - 650°C, 400V~ - in accordance with IEC 60670-1 	
	BM40	<p>KRABICA OBDĹŽNIKOVÁ DO BETÓNU BM4</p> <ul style="list-style-type: none"> - veľkosť 4M, hĺbka 60 mm - 650°C, 400V~ - vyhovuje IEC 60670-1 <p><i>RECTANGULAR BOX CONCRETE BM4</i></p> <ul style="list-style-type: none"> - size 4M, depth 60mm - 650°C, 400V~ - in accordance with IEC 60670-1 	
	BM70	<p>KRABICA OBDĹŽNIKOVÁ DO BETÓNU BM7</p> <ul style="list-style-type: none"> - veľkosť 7M, hĺbka 60 mm - 650°C, 400V~ - vyhovuje IEC 60670-1 <p><i>RECTANGULAR BOX CONCRETE BM7</i></p> <ul style="list-style-type: none"> - size 7M, depth 60mm - 650°C, 400V~ - in accordance with IEC 60670-1 	
	BM80	<p>FIXAČNÝ ČLÁNOK NA KRABICE BM</p> <ul style="list-style-type: none"> - na rýchle upevnenie obdĺžnikovných krabíc BM na armováciu sietku - vhodný na tyče max. priemeru Ø8 mm <p><i>FIXING COMBI-CLIP BM</i></p> <ul style="list-style-type: none"> - for fast fixation of BM rectangular boxes on reinforcing bar - suitable for bar diameter up to Ø8mm 	
	BM82	<p>DIŠŤANČNÝ PROFIL NA KRABICE BM</p> <ul style="list-style-type: none"> - na upevnenie krabíc BM spolu s s montážnym rámikom pre betón do protiahlej steny - dĺžka l=1m, priemer Ø20mm <p><i>DISTANCE PROFIL FOR BOXES BM</i></p> <ul style="list-style-type: none"> - to support boxes BM with counter box support on opposite wall - length l=1m, diameter Ø20mm 	



tehla / brick



duté steny / hollow walls



betón / concrete



DM30		 NM30	3M
HM30			
BM30			
DM40		 NM40	4M
HM40			
BM40			
DM70		 NM70	7M
HM70			
BM70			
DM72		 NM72	2x7M
HM72			
DM30		 NM32	2/3M
HM30			
BM30			

R E C T A N G U L A R B O X E S

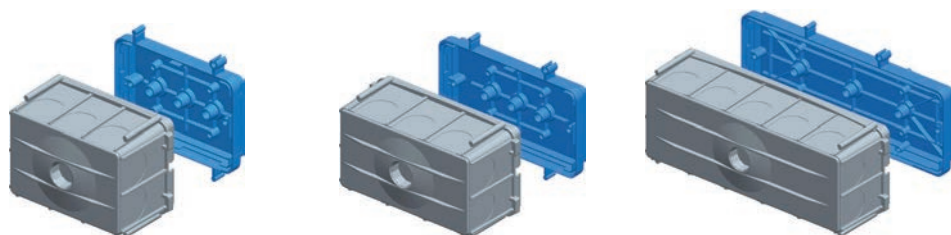

návod na montáž /
assembly instructions

1

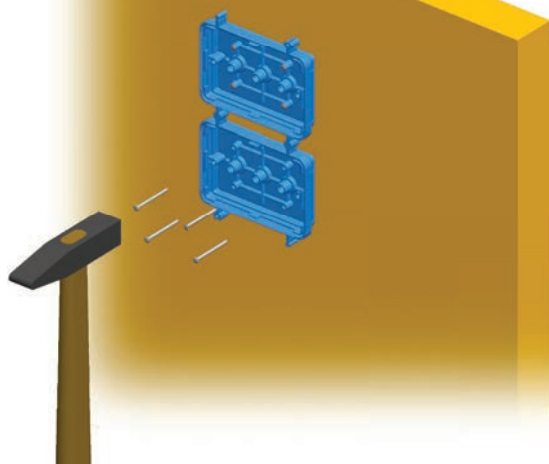

2

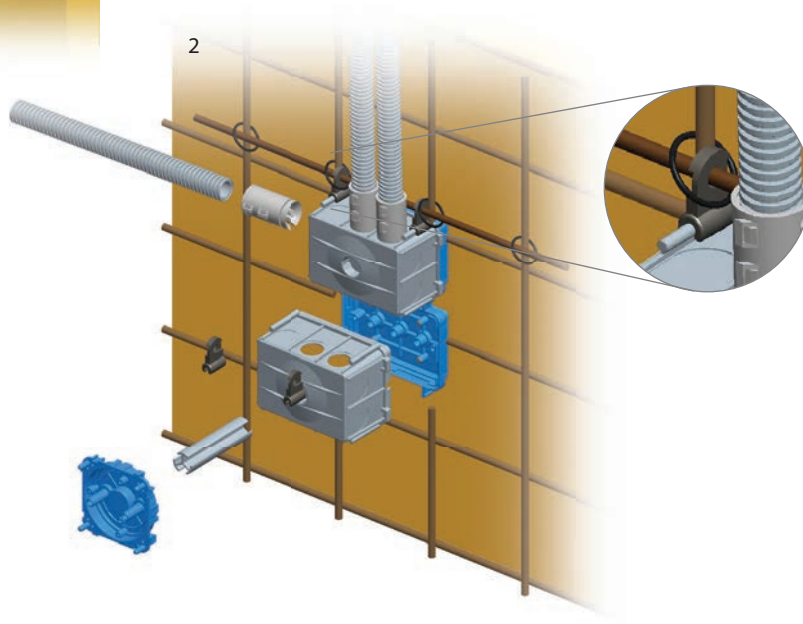

3

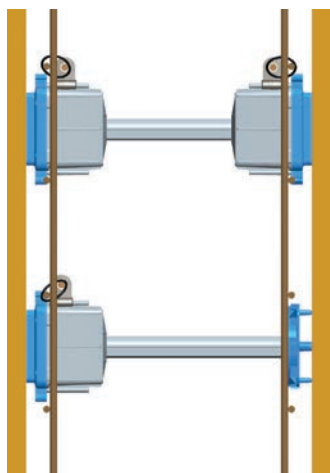

4

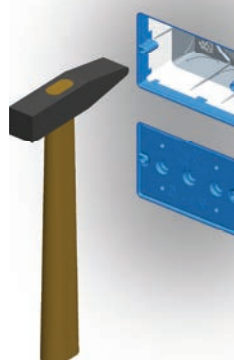



DW10

ROZVODNÁ KRABICA OKRÚHLA DO STENY DSM78

- Ø78, hĺbka 40 mm
- 650°C, 500V~
- vyhovuje IEC 60670-1 a IEC 60670-22
- bezhalogénový

CONNECTION ROUND BOX BRICK DSM78

- Ø78, depth 40mm
- 650°C, 500V~
- in accordance with IEC 60670-1 and IEC 60670-22
- halogen free

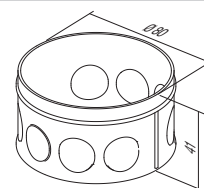

HW10

ROZVODNÁ KRABICA OKRÚHLA PRE DUTÉ STENY SM78x45

- Ø78, hĺbka 45 mm
- montáž do otvoru Ø80
- 850°C, 400V~
- vyhovuje IEC 60670-1 a IEC 60670-22
- montáž svorkami
- bezhalogénový

CONNECTION ROUND BOX HOLLOW WALL SM78x45

- Ø78, depth 45mm
- cutting hole Ø80
- 850°C, 400V~
- in accordance with IEC 60670-1 and IEC 60670-22
- mounting with claws
- halogen free

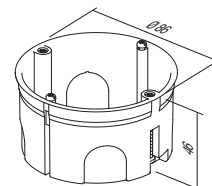

DE23

KRYT KRABICE DEKORATÍVNY SM78

- dekoratívny kryt krabice Ø78
- vyhovuje IEC 60670-1 a IEC 60670-22
- bezhalogénový

BOX COVER DECORATIVE SM78

- decorative cover for boxes Ø78
- in accordance with IEC 60670-1 and IEC 60670-22
- halogen free

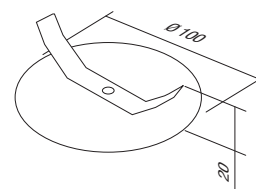

DE24

KRYT KRABICE OCHRANNÝ 78

- ochranný kryt krabice Ø78
- vyhovuje IEC 60670-1 a IEC 60670-22
- bezhalogénový

BOX COVER PROTECTIVE 78

- protective cover for box Ø78
- in accordance with IEC 60670-1 and IEC 60670-22
- halogen free

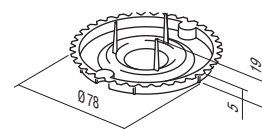

HW20

ROZVODNÁ KRABICA ŠTVORCOVÁ DO STENY SM105x105

- 105x105mm, hĺbka 50 mm
- montáž do otvoru podľa priloženej šablóny
- 850°C, 400V~
- vyhovuje IEC 60670-1 a IEC 60670-22
- montáž svorkami
- bezhalogénový

CONNECTION SQUARE BOX BRICK SM105x105

- size 105x105mm, depth 50mm
- cutting hole according to attached template
- 850°C, 400V~
- in accordance with IEC 60670-1 and IEC 60670-22
- mounting with claws
- halogen free

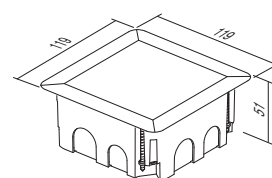

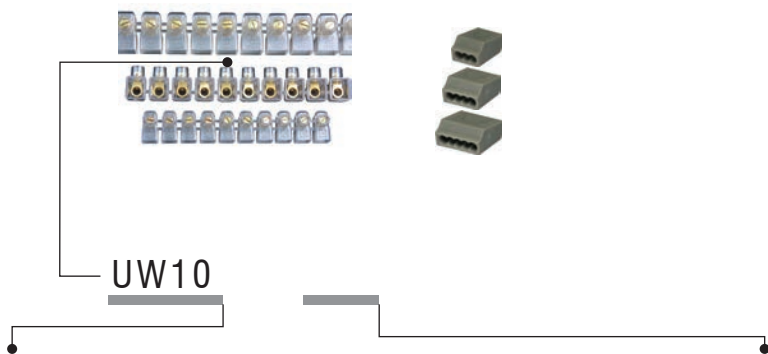

Typ type	názov description	technické údaje technical data	veľkosť size	farba colour
UW10	JEDNORADOVÁ SVORKOVNICA ZATVORENÁ 1 ROW TERMINAL BLOCKS	2x2.5mm ²	10P	TS transparentná transparent
UW11	JEDNORADOVÁ SVORKOVNICA ZATVORENÁ 1 ROW TERMINAL BLOCKS	2x4mm ²	10P	CO farebná colour
UW12	JEDNORADOVÁ SVORKOVNICA ZATVORENÁ 1 ROW TERMINAL BLOCKS	2x6mm ²	10P	WH biela white
.	.	.	.	GY sivá grey

JEDNORADOVÁ SVORKOVNICA ZATVORENÁ



- 450V~; 2x2,5 mm² ÷ 2 x 6 mm²
- termoplast PC, transparentné
- počet pólov: 10

1 ROW TERMINAL BLOCKS CLOSED

- 450V~; 2x2,5mm² ÷ 2x6mm²
- termoplast PC, transparent
- number of poles: 10

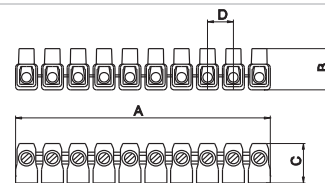

UW10TS	(NS12)	2x2.5mm ²	10P
UW11TS	(NS12)	2x4mm ²	10P
UW12TS	(NS12)	2x6mm ²	10P

	A	B	C	D
2x2.5 □	110	17.5	17.5	11
2x4 □	128	21	19	12.5
2x6 □	146	21.5	22	15

JEDNORADOVÉ SVORKOVNICE



- 450V~; 2x2,5 mm² ÷ 2 x 6 mm²
- termoplast PA
- k dispozícii v rozličných farbách
- počet pólov: 12

1 ROW TERMINAL BLOCKS

- 450V~; 2x2,5mm² ÷ 2x6mm²
- termoplast PA
- available in different colours
- number of poles: 12

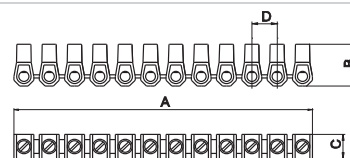

UW15CO	(NS12)	2x2.5mm ²	12P
UW16CO	(NS12)	2x4mm ²	12P
UW17CO	(NS12)	2x6mm ²	12P

	A	B	C	D
2x2.5 □	110	16.4	9	10
2x4 □	118.8	19	10	10
2x6 □	129.8	21.3	11	11.8

DVOJRADOVÉ SVORKOVNICE

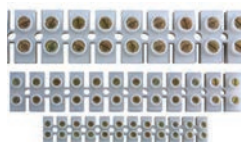

- 450V~; 1,5mm² ÷ 16 mm²
- termoplast PA, biela
- počet pólov: 12

2 ROW TERMINAL BLOCKS

- 450V~; 1,5mm² ÷ 16mm²
- termoplast PA, white
- number of poles: 12

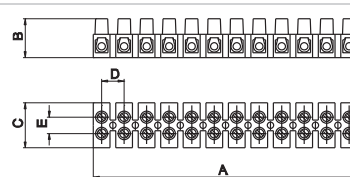

UW20WH	(P7)	2.5-4.0mm ²	12P
UW21WH	(P9)	4.0-6.0mm ²	12P
UW22WH	(P12)	6.0-10mm ²	12P
UW23WH	(P14)	16mm ²	12P

	A	B	C	D	E
1.5 □	119.5	17	20	10	8
2.5 □	118	17	20	10	8
4-6 □	129.2	19	22	11	8
10 □	147	23	25	12.5	9
16 □	177	29	30	15	13

BEZSKRUTKOVÉ SVORKY



- 24A 450V~, termoplast PA, sivé
- počet pólov: 3÷8
- bezskrutkové kontakty 0,5 ÷ 1,5 mm², pre vodiče pevné
- vyhovuje EN 60998-1

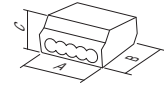

PLUG-IN WIRE CONNECTORS

- 24A 450V~, thermoplast PA, grey
- number of poles: 3÷8
- plug-in contacts 0,5÷1,5mm², for rigid wires
- in accordance with EN 60998-1

				A	B	C	
UW40GY	PC153	1.5mm ²	3P	3P	12	18	9
UW41GY	PC155	1.5mm ²	5P	5P	17	18	9
UW42GY	PC158	1.5mm ²	8P	8P	26	18	9

BEZSKRUTKOVÉ SVORKY



- 24A 450V~, termoplast PA, sivé
- počet pólov: 3÷5
- bezskrutkové kontakty 1,5 ÷ 2,5 mm², pre vodiče pevné
- vyhovuje EN 60998-1

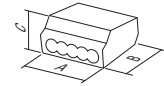

PLUG-IN WIRE CONNECTORS

- 24A 450V~, thermoplast PA, grey
- number of poles: 3÷5
- plug-in contacts 1,5÷2,5mm², for rigid wires
- in accordance with EN 60998-1

				A	B	C	
UW45GY	PC253	2.5mm ²	3P	3P	14	19	9
UW46GY	PC254	2.5mm ²	4P	4P	17	19	9
UW47GY	PC255	2.5mm ²	5P	5P	21	19	9

BEZSKRUTKOVÉ SVORKY



- 24A 450V~, termoplast PA, sivé
- počet pólov: 2 (tvrdý vodič) +1 (vodiče lankové)
- bezskrutkové kontakty 1,5 ÷ 2,5 mm²
- vyhovuje EN 60998-1

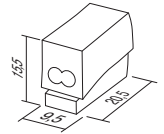

PLUG-IN WIRE CONNECTOR

- 24A 450V~, thermoplast PA, grey
- number of poles: 2 (rigid wire)+1 (soft wire)
- plug-in contacts 1,5÷2,5mm²
- in accordance with EN 60998-1

UW50WH	PC302	2.5mm ²	2/1P			
--------	-------	--------------------	------	--	--	--

TEM

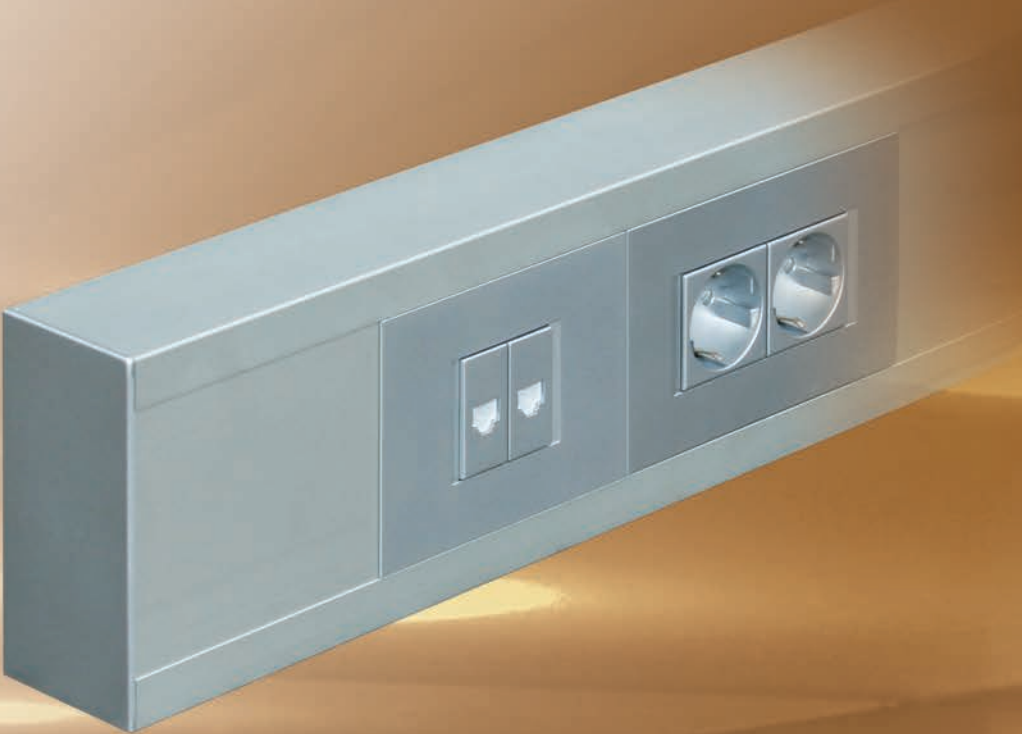

KATALOG / CATALOGUE

distribúcia



RÁMY CUBO IP20 AC
BOXES CUBO IP20 AC



140

RÁMY CUBO IP55 AQ
BOXES CUBO IP55 AQ



141

INŠTALAČNÉ KANÁLY HLINÍKOVÉ MA
TRUNKING SYSTEM ALUMINIUM MA



142

PODLAHOVÉ KRABICE MT
FLOOR BOXES MT



147

ROZVODNÉ SKRINKY MO
DISTRIBUTION BOARDS MO



150

AC21

PW

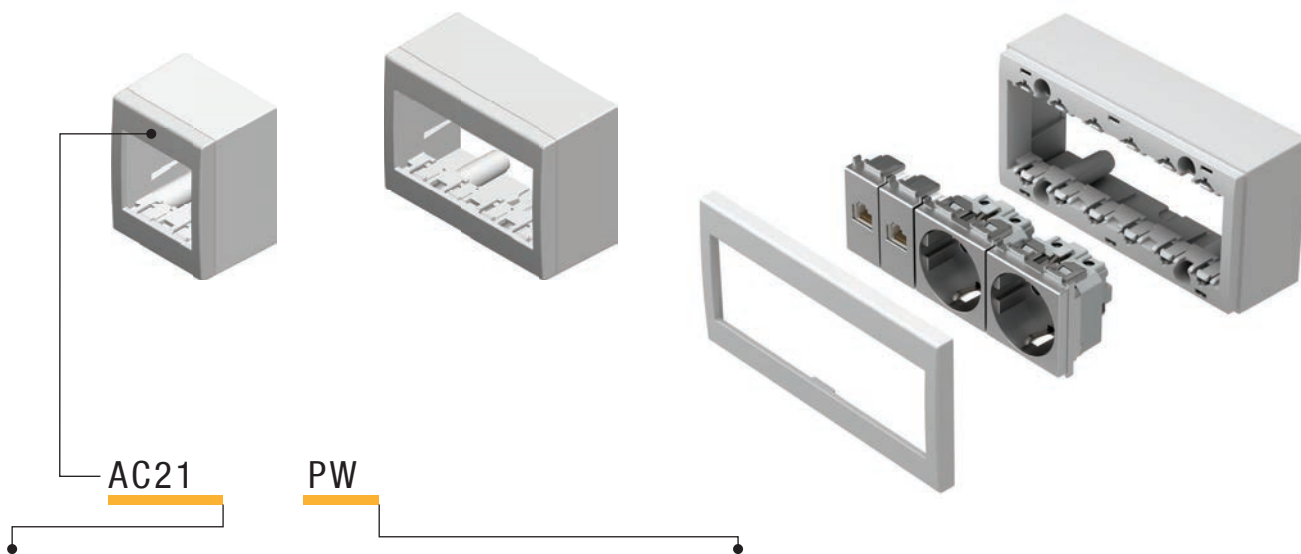

Typ type	názov description	technické údaje technical data	veľkosť size	farba colour
AC11	RÁM NO CUBO SURFACE MOUNT BOX	IP20	1M	<input type="checkbox"/> PW biely-lesklý polar white
AC21	RÁM NO CUBO SURFACE MOUNT BOX	IP20	2M	<input type="checkbox"/> ES strieborný-matný elox silver
AC41	RÁM NO CUBO SURFACE MOUNT BOX	IP20	4M	<input type="checkbox"/> IW slonová kost-lesklý ivory white
⋮		⋮	⋮	

distribúcia

RÁM NO CUBO IP20 1M



- AC11PW
- AC11ES
- AC11IW

- rám IP20 1M
- na povrchovú montáž prvkov
- vhodný na spínače SM
- vyhovuje EN 60669-1

SURFACE MOUNT BOX NO CUBO IP20 1M
- box IP20 1M
- for surface mounting of elements
- suitable to SM switches
- in accordance with EN 60669-1

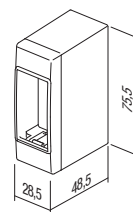

RÁM NO CUBO IP20 2M



- AC21PW
- AC21ES
- AC21IW

- rám IP20 2M
- na povrchovú montáž prvkov
- vyhovuje EN 60669-1, EN60884-1

SURFACE MOUNT BOX NO CUBO IP20 2M
- box IP20 2M
- for surface mounting of elements
- in accordance with EN 60669-1, EN60884-1

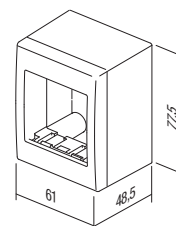

RÁM NO CUBO IP20 4M

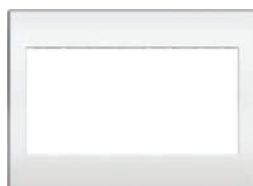

- AC41PW
- AC41ES
- AC41IW

- rám IP20 4M
- na povrchovú montáž prvkov
- vyhovuje EN 60669-1, EN60884-1

SURFACE MOUNT BOX NO CUBO IP20 4M
- box IP20 4M
- for surface mounting of elements
- in accordance with EN 60669-1, EN60884-1

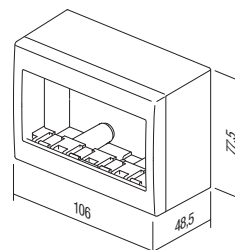

RÁM NO CUBO IP20 6M

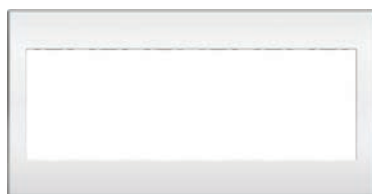

- AC61PW
- AC61ES
- AC61IW

- rám IP20 6M
- na povrchovú montáž prvkov
- vyhovuje EN 60669-1, EN60884-1

SURFACE MOUNT BOX NO CUBO IP20 6M
- box IP20 6M
- for surface mounting of elements
- in accordance with EN 60669-1, EN60884-1

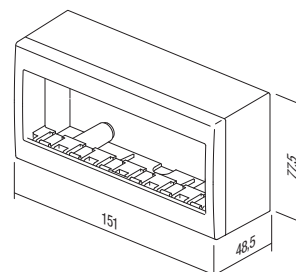

B O X E S C U B O I P 5 5 A Q



Typ type	názov description	technické údaje technical data	veľkosť size	farba colour
AQ20	RÁM NO CUBO OUTDOOR SURFACE MOUNT BOX	IP55	2M	<input type="checkbox"/> PW biely-lesklý polar white
AQ30	RÁM NO CUBO OUTDOOR SURFACE MOUNT BOX	IP55	3M	<input checked="" type="checkbox"/> GY sivá grey
AQ31	RÁM PC CUBO IP55 OUTDOOR FLUSH MOUNT BOX	IP55	3M	

RÁM NO CUBO IP55 2M



- AQ20PW
 AQ20GY

- rám IP 55 2M
- na povrchovú montáž
- IP55 na inštaláciu do vlhkých miestností
- vyhovuje CEI 23-48, EN 60670

OUTDOOR SURFACE MOUNT BOX NO CUBO IP55 2M

- box IP55 2M
- for surface mounting
- IP55 for usage in humid areas
- in accordance with CEI 23-48, EN 60670

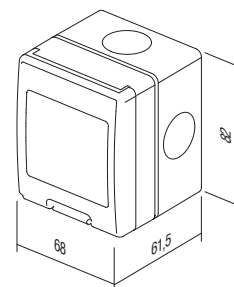

RÁM NO CUBO IP55 3M



- AQ30PW
 AQ30GY

- rám IP55 3M
- na povrchovú montáž
- IP55 na inštaláciu do vlhkých miestností
- vyhovuje CEI 23-48, EN 60670

OUTDOOR SURFACE MOUNT BOX NO CUBO IP55 3M

- box IP55 3M
- for surface mounting
- IP55 for usage in humid areas
- in accordance with CEI 23-48, EN 60670

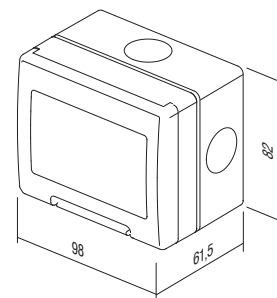

RÁM PO CUBO IP55 3M



- AQ31PW
 AQ31GY

- rám IP55 3M
- na zapustenú montáž
- IP55 na inštaláciu do vlhkých miestností
- vyhovuje CEI 23-48, EN 60670

OUTDOOR FLUSH MOUNT BOX PO CUBO IP55 3M

- box IP55 3M
- for flush mounting
- IP55 for usage in humid areas
- in accordance with CEI 23-48, EN 60670

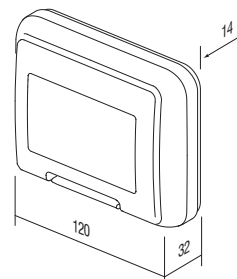

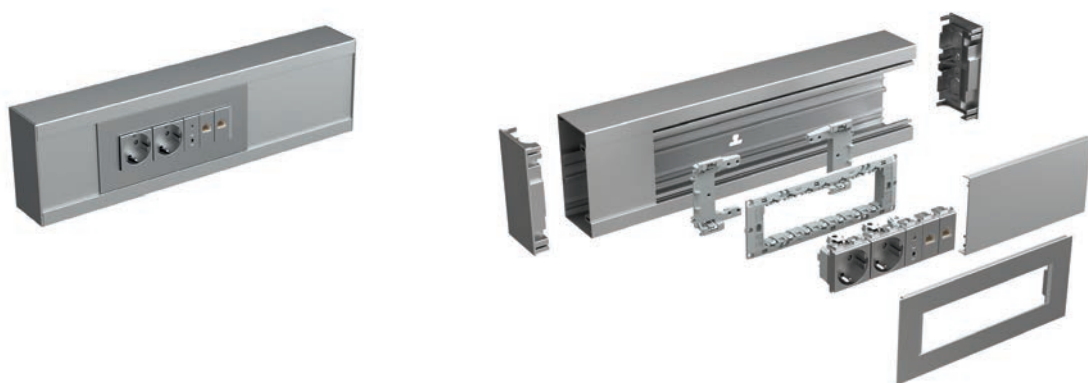

RT20

ES

Typ type	názov description	veľkosť size	farba colour
RT10	ADAPTÉR MA 92 ADAPTER MA 92	/	■ ES strieborný-matný elox silver-mat
RT12	RÁMIK MA 92 COVER PLATE MA 92	2/3M	□ PW biela - matná (RAL 9016) white-mat
RT14	RÁMIK MA 92 COVER PLATE MA 92	4M	

ADAPTÉR MA 92



RT10

- adaptér na upevnenie montážnych dosiek 2/3M, 4M alebo 7M Modul na kanál MA bez krabice
- každý montážny rámik si vyžaduje dva adaptéry
- vyhovuje EN 50085-1

ADAPTER MA 92
- adapter for fixing mounting frames 2/3M, 4M or 7M on MA trunking without box
- each mounting frame needs two adapters
- in accordance with EN 50085-1

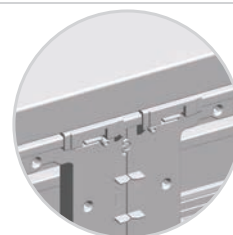

RÁMIK MA 92 2/3M



- RT12ES
- RT12PW

- dekoratívny rámik MA 2/3M
- vyhovuje EN 50085-1

COVER PLATE MA 92 2/3M
- decorative cover plate MA 2/3M
- in accordance with EN 50085-1

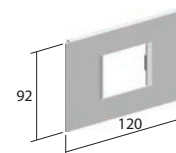

RÁMIK MA 92 4M



- RT14ES
- RT14PW

- dekoratívny rámik MA 4M
- vyhovuje EN 50085-1

COVER PLATE MA 92 4M
- decorative cover plate MA 4M
- in accordance with EN 50085-1

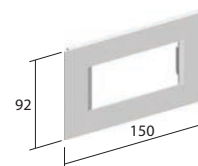

RÁMIK MA 92 7M

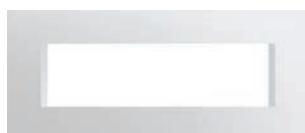

- RT17ES
- RT17PW

- dekoratívny rámik MA 7M
- vyhovuje EN 50085-1

COVER PLATE MA 92 7M
- decorative cover plate MA 7M
- in accordance with EN 50085-1

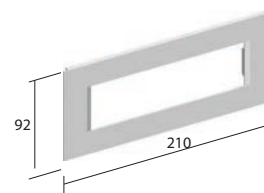

ZÁKLAD KANÁLA MA 130x65



- RT20ES
- RT20PW

- základ kanála z ťahaného hliníka
- výška 130 mm, dĺžka 2 m
- DIN lišta 35 mm na dne
- vyhovuje EN 50085-1

TRUNKING BASE MA 130x65

- trunking base from extruded aluminium
- height 130mm, length 2m
- DIN - rail 35mm shape on bottom
- in accordance with EN 50085-1

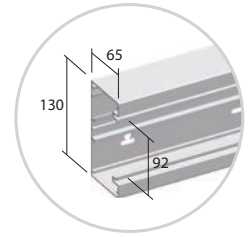

ZÁKLAD KANÁLA MA 165x65



- RT21ES
- RT21PW

- základ kanála z ťahaného hliníka
- výška 165 mm, dĺžka 2 m
- DIN lišta 35 mm na dne
- vyhovuje EN 50085-1

TRUNKING BASE MA 165x65

- trunking base from extruded aluminium
- height 165mm, length 2m
- DIN - rail 35mm shape on bottom
- in accordance with EN 50085-1

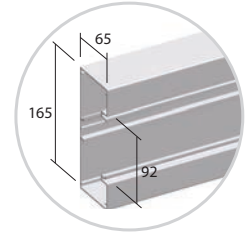

KRYT NA KANÁL MA 92



- RT25ES
- RT25PW

- kryt na kanál z ťahaného hliníka
- výška 92 mm, dĺžka 2 m
- vyhovuje EN 50085-1

FRONT COVER MA 92

- front cover from extruded aluminium
- height 92mm, length 2m
- in accordance with EN 50085-1

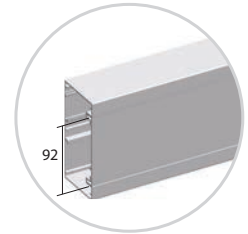

PRIEHRADKA MA 43



RT30

- priehradka kanála z ťahaného hliníka
- hĺbka 43 mm, dĺžka 2 m
- vyhovuje EN 50085-1

CABLE SHELF MA 43

- cable shelf from extruded polymer
- depth 43mm, length 2m
- in accordance with EN 50085-1

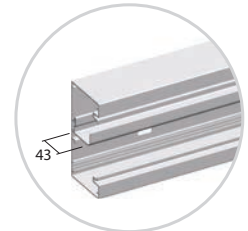

PRIEHRADKA MA 43 AL



RT31

- priehradka kanála z ťahaného hliníka
- hĺbka 43 mm, dĺžka 2 m
- vyhovuje EN 50085-1

CABLE SHELF MA 43 AL

- cable shelf from extruded aluminium
- depth 43mm, length 2m
- in accordance with EN 50085-1

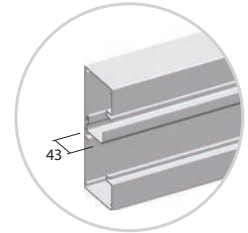

PRIEHRADKA MA 43 AL DVOJITÁ



RT32

- dvojitá priehradka kanála z ťahaného hliníka
- hĺbka 43 mm, dĺžka 2 m
- vyhovuje EN 50085-1

CABLE SHELF MA 43 AL DOUBLE

- double cable shelf from extruded aluminium
- depth 43mm, length 2m
- in accordance with EN 50085-1

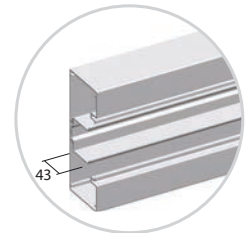



- RT35ES
- RT35PW

KONCOVÝ PRVOK MA 130x65

- koncový prvok z polyméru
- výška 130 mm
- vyhovuje EN 50085-1

STOP END MA 130x65
 - stop end element from polymer
 - height 130mm
 - in accordance with EN 50085-1

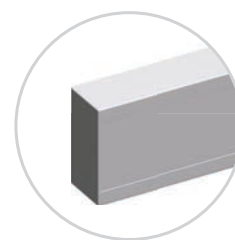

- RT36ES
- RT36PW

KONCOVÝ PRVOK MA 165x65

- koncový prvok z kovu
- výška 165 mm
- vyhovuje EN 50085-1

STOP END MA 165x65
 - stop end element from metal
 - height 165mm
 - in accordance with EN 50085-1

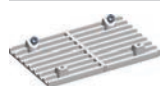
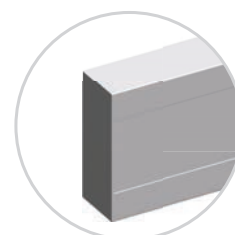

RT38

SADA ROVNÝ SPOJOVACÍ PRVOK MA 65

- spojovací prvok z polyméru
- sada obsahuje 2 spojovacie prvky a skrutky
- vyhovuje EN 50085-1

JOINING PIECE MA 65
 - joining piece from polymer
 - set contains two pieces and screws
 - in accordance with EN 50085-1

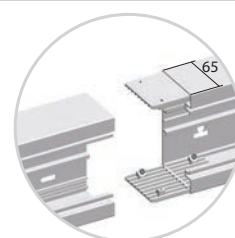

- RT40ES
- RT40PW

UNIVERZÁLNY ROH MA 130x65

- univerzálny rohový prvok
- výška 130 mm
- vyhovuje EN 50085-1

UNIVERSAL CORNER MA 130x65
 - universal corner element
 - height 130mm
 - in accordance with EN 50085-1

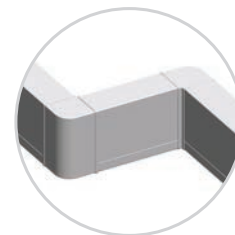

- RT41ES
- RT41PW

UNIVERZÁLNY ROH MA 165x65

- univerzálny rohový prvok
- výška 165 mm
- vyhovuje EN 50085-1

UNIVERSAL CORNER MA 165x65
 - universal corner element
 - height 165mm
 - in accordance with EN 50085-1

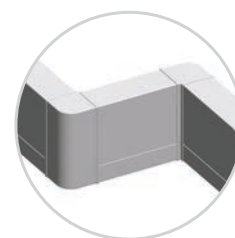

RT42

UZEMŇOVACIA SVORKA MA 2 x A6.3

- uzemňovacia svorka na uzemnenie základu a krytu kanálu
- vyhovuje EN 50085-1

EARTHING PIECE MA 2x A6.3
 - earthing piece for earthing of trunking base and front cover
 - in accordance with EN 50085-1

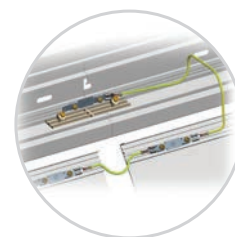

L KONCOVÝ PRVOK MA 130x65

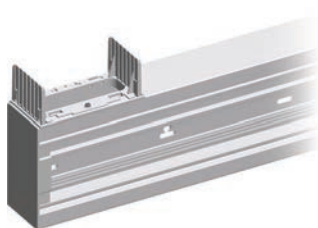

- RT43ES
- RT43PW

- univerzálny L rohový prvok z hliníka
- výška 130 mm, dĺžka 400 mm
- vyhovuje EN 50085-1

L-BEND MA 130x65
- universal L bend element from aluminium
- height 130mm, length 400mm
- in accordance with EN 50085-1

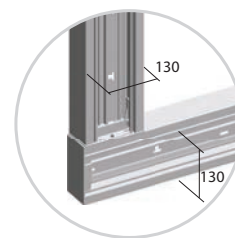

L KONCOVÝ PRVOK MA 165x65

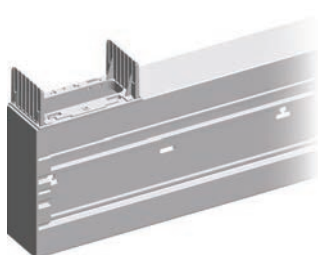

- RT44ES
- RT44PW

- univerzálny L rohový prvok z hliníka
- výška 165 mm, dĺžka 400 mm
- spojenie na MA 130 x 65
- vyhovuje EN 50085-1

L-BEND MA 165x65
- universal L bend element from aluminium
- height 165mm, length 400mm
- connection on MA 130x65
- in accordance with EN 50085-1

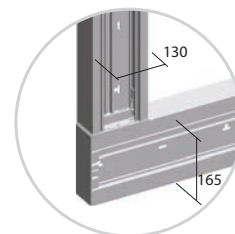

T PRVOK MA 130x65

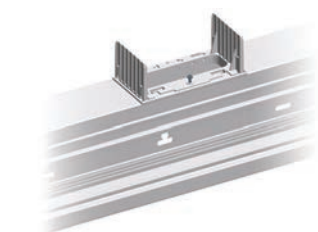

- RT45ES
- RT45PW

- univerzálny T rohový prvok z hliníka
- výška 130 mm, dĺžka 400 mm
- vyhovuje EN 50085-1

T-BEND MA 130x65
- universal T bend element from aluminium
- height 130mm, length 400mm
- in accordance with EN 50085-1

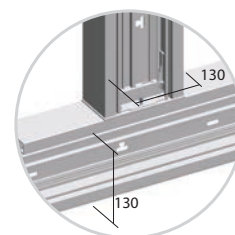

T PRVOK MA 165x65

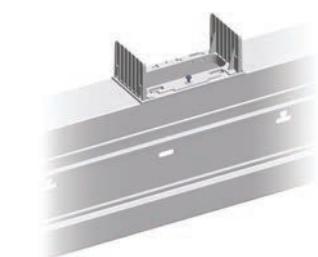

- RT46ES
- RT46PW

- univerzálny T rohový prvok z hliníka
- výška 165 mm, dĺžka 400 mm
- spojenie na MA 130 x 65
- vyhovuje EN 50085-1

T-BEND MA 165x65
- universal T bend element from aluminium
- height 165mm, length 400mm
- connection on MA 130x65
- in accordance with EN 50085-1

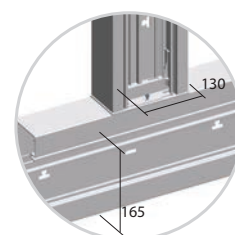

MA je modulárny systém pre veľkosti: 2M, 4M, 7M

MA trunking is based on a modular system that creates 2M, 4M or 7M combinations of elements



Modul obsahuje aj prvky pripravené na rýchlu montáž

Our Modul line provides special elements for quick installation

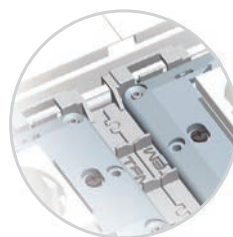

Adaptér MA umožňuje presné umiestnenie na roh kanála

The MA Adapter enables exact positioning without extra effort

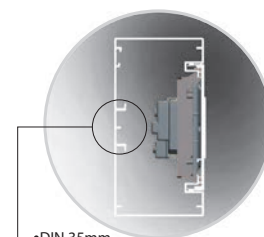

Montáž bez krabice znamená viac priestoru pre káble, DIN lišta forma EN-60715

Mounting without a box means more space for cables, DIN-rail base shape EN-60715

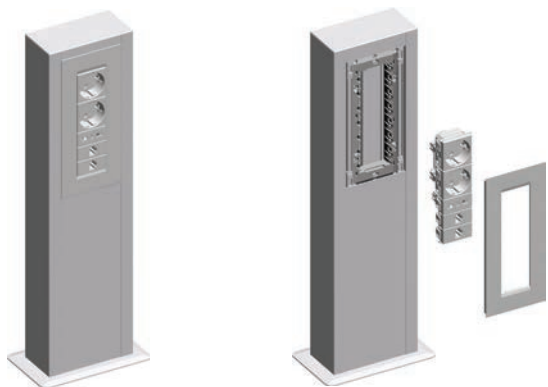

NOSNÍK STĚPÍKA MA DVOJITÝ 130x65



- RT50ES
- RT50PW

- nosník na upevnenie kanála MA130 do podlahy a/alebo stropu miestnosti
- vyhovuje EN 50085-1

FIXING PLATE MA SINGLE 130x65

- fixing plate for fixing trunking base MA130 on the floor and/or on the ceiling
- in accordance with EN 50085-1

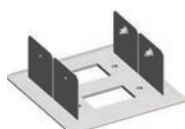

- RT51ES
- RT51PW

NOSNÍK STĚPÍKA MA DVOJITÝ 165x65

- nosník na upevnenie dvoch kanálov MA130 do podlahy a/alebo stropu miestnosti
- vyhovuje EN 50085-1

FIXING PLATE MA DOUBLE 130x65

- fixing plate for fixing two trunking bases MA130 on the floor and/or on the ceiling
- in accordance with EN 50085-1

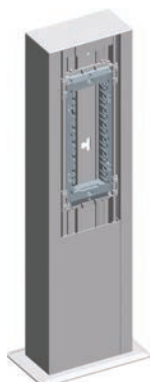

- RT52ES
- RT52PW

STĚPÍK MA 130x65x500

- inštalačný stěpík MA
- výška 500 mm
- nosník 7M zabudovaný
- vyhovuje EN 50085-1

SERVICE POST MA 130x65x500

- service post MA
- height 500mm
- mounting frame 7M included
- in accordance with EN 50085-1

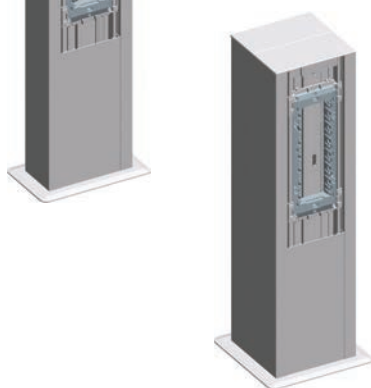

- RT53ES
- RT53PW

STĚPÍK MA DVOJITÝ 130x130x500

- inštalačný stěpík MA dvojité
- výška 500 mm
- nosníky 7M zabudované
- vyhovuje EN 50085-1

SERVICE POST MA DOUBLE 130x130x500

- service post MA double
- height 500mm
- mounting frames 7M included
- in accordance with EN 50085-1

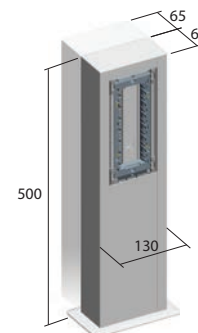

Prierez vodiča mm ² / Cable intersection mm ²	Použitelný prierez káblov / Cable cross-section (mm ²)				
	1 vodič/ 1 wire	2 vodiče/ 2 wires	3 vodiče/ 3 wires	4 vodiče/ 4 wires	5 vodičov/ 5 wires
1,5	44	111	121	144	169
2,5	49	133	157	169	211
4	58	169	183	211	256
6	68	196	225	256	307

Kapacita kanála / Trunk capacity				
kanál/ trunk	MA 130x65 prázdny/ empty	MA 130x65 s Modul príslušenstvom/ with Modul switches and sockets	MA 165x65 prázdny/ empty	MA 165x65 s Modul príslušenstvom/ with Modul switches and sockets
kapacita/capacity	7600 mm ²	5500 mm ²	9900 mm ²	7800 mm ²
max ø/max ø	54 mm	2x42 mm	54 mm	2x42 mm

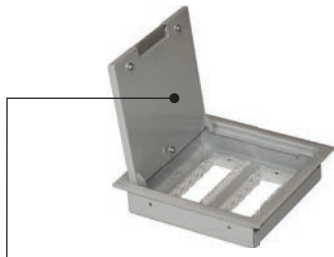
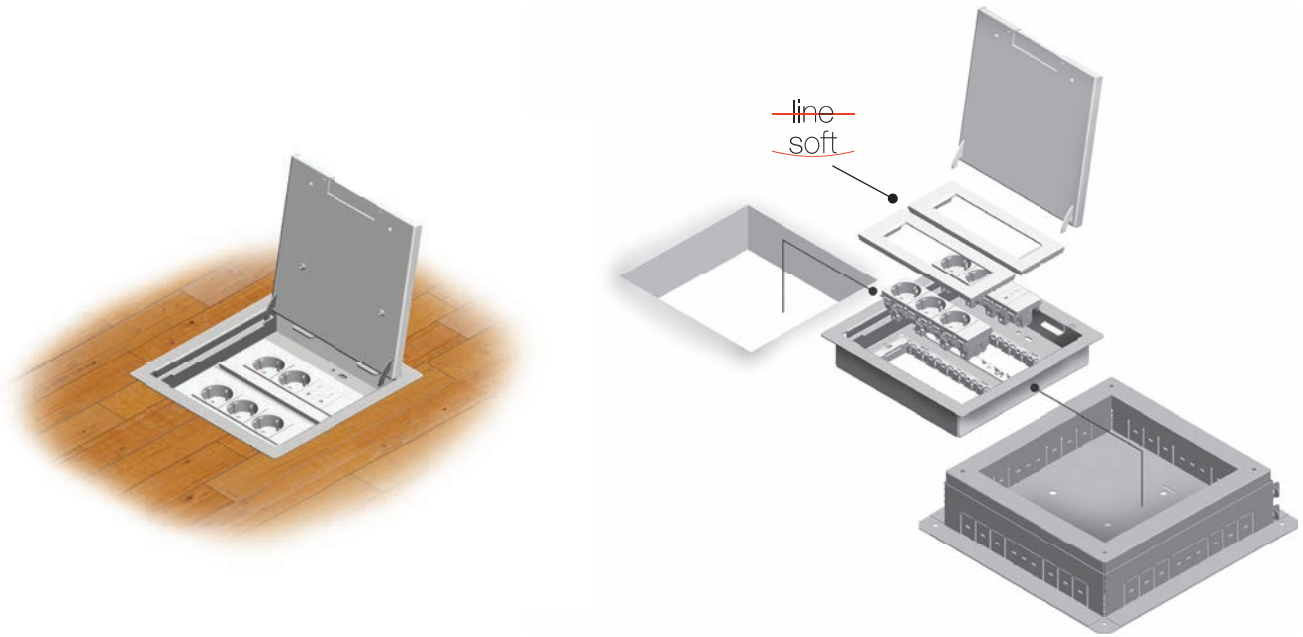

RB33

Typ type	názov description	technické údaje technical data
RB30	PODLAHOVÁ KRABICA FLOOR BOX	MT 7
RB31	PODLOŽKA PODLAHOVEJ KRABICE FLOOR BOX FLANGE	MT 7
RB33	PODLAHOVÁ KRABICA FLOOR BOX	MT 14
:	:	:
:	:	:

	RB30	RB33	RB36	RB40	RB43	RB46
a	170	260	350	170	260	350
b	260	260	260	260	260	260
X	140	230	320	140	230	320
Y	230	230	230	230	230	230

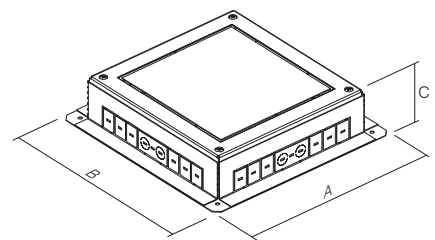
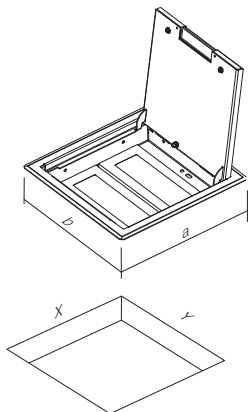

	RB31	RB34	RB37	RB41	RB44	RB47
A	270	360	450	270	360	450
B	360	360	360	360	360	360
C	95-125	95-125	95-125	120-150	120-150	120-150

PODLAHOVÁ KRABICA MT 7



RB30

- podlahová krabica MT 7
- kovová, farba strieborná RAL 9006
- montážny rámik MODUL 7M zabudovaná
- inštalčné rozmery 140 x 230 mm, hĺbka min. 95 mm
- hrúbka podlahového obkladu krytu do 10 mm
- vyhovuje EN 50085-1 a EN 50085-2-2

FLOOR BOX MT 7

- floor box MT 7
- metal, colour silver RAL 9006
- mounting frame MODUL 7M included
- mounting dimensions 140x230mm, depth min 95mm
- floor lining thickness up to 10mm
- in accordance with EN 50085-1 and EN 50085-2-2

PODLAHOVÁ KRABICA MT 7 H=88 mm



RB40

- podlahová krabica MT 7
- kovová, farba strieborná RAL 9006
- montážny rámik MODUL 7M zabudovaná
- inštalčné rozmery 140 x 230mm, hĺbka min. 120 mm
- hrúbka podlahového obkladu krytu do 10 mm
- vyhovuje EN 50085-1 a EN 50085-2-2

FLOOR BOX MT 7 H=88mm

- floor box MT 7
- metal, colour silver RAL 9006
- mounting frame MODUL 7M included
- mounting dimensions 140x230mm, depth min 120mm
- floor lining thickness up to 10mm
- in accordance with EN 50085-1 and EN 50085-2-2

PODLOŽKA PODLAHOVEJ KRABICE MT 7

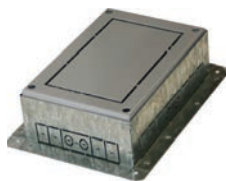

RB31

- podložka podlahovej krabice pre kryt MT 7
- kovová pozinkovaná
- na inštaláciu do podlahy alebo dvojitej podlahy
- nastaviteľná výška 95-125 mm
- vyhovuje EN 50085-1 a EN 50085-2-2

FLOOR BOX FLANGE MT 7

- floor box flange for box cover MT 7
- metal, galvanized
- for installation in a floor or double floor
- adjustable height 95-125mm
- in accordance with EN 50085-1 and EN 50085-2-2

PODLOŽKA PODLAHOVEJ KRABICE MT 7 H=88 mm

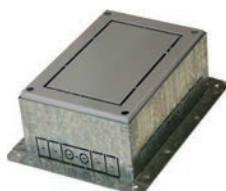

RB41

- podložka podlahovej krabice pre kryt MT 7 H=88 mm
- kovová pozinkovaná
- na inštaláciu do podlahy alebo dvojitej podlahy
- nastaviteľná výška 120-150 mm
- vyhovuje EN 50085-1 a EN 50085-2-2

FLOOR BOX FLANGE MT 7 H=88mm

- floor box flange for box cover MT 7 H=88mm
- metal, galvanized
- for installation in a floor or double floor
- adjustable height 120-150mm
- in accordance with EN 50085-1 and EN 50085-2-2

PODLAHOVÁ KRABICA MT 14



RB33

- podlahová krabica MT 14
- kovová, farba strieborná RAL 9006
- montážne rámiky MODUL 2x7M zabudované
- inštalčné rozmery 230 x 230mm, hĺbka min. 95 mm
- hrúbka podlahového obkladu krytu do 10 mm
- vyhovuje EN 50085-1 a EN 50085-2-2

FLOOR BOX MT 14

- floor box MT 14
- metal, colour silver RAL 9006
- mounting frames MODUL 2x7M included
- mounting dimensions 230x230mm, depth min 95mm
- floor lining thickness up to 10mm
- in accordance with EN 50085-1 and EN 50085-2-2

PODLAHOVÁ KRABICA MT 14 H=88mm



RB43

- podlahová krabica MT 14
- kovová, farba strieborná RAL 9006
- montážne rámiky MODUL 2x7M zabudované
- inštalčné rozmery 230 x 230mm, hĺbka min. 120 mm
- hrúbka podlahového obkladu krytu do 10 mm
- vyhovuje EN 50085-1 a EN 50085-2-2

FLOOR BOX MT 14 H=88mm

- floor box MT 14
- metal, colour silver RAL 9006
- mounting frames MODUL 2x7M included
- mounting dimensions 230x230mm, depth min 120mm
- floor lining thickness up to 10mm
- in accordance with EN 50085-1 and EN 50085-2-2

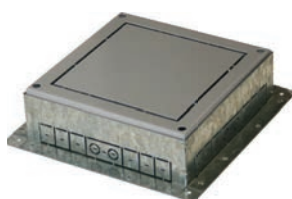
PODLOŽKA PODLAHOVEJ KRABICE MT 14

RB34

- podložka podlahovej krabice pre kryt MT 14
- kovová pozinkovaná
- na inštaláciu do podlahy alebo dvojitej podlahy
- nastaviteľná výška 95-125 mm
- vyhovuje EN 50085-1 a EN 50085-2-2

FLOOR BOX FLANGE MT 14

- floor box flange for box cover MT 14
- metal, galvanized
- for installation in a floor or double floor
- adjustable height 95-125mm
- in accordance with EN 50085-1 and EN 50085-2-2

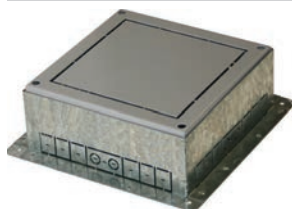
PODLOŽKA PODLAHOVEJ KRABICE MT 14 H=88 mm

RB44

- podložka podlahovej krabice pre kryt MT 14 H=88 mm
- kovová pozinkovaná
- na inštaláciu do podlahy alebo dvojitej podlahy
- nastaviteľná výška 120-150 mm
- vyhovuje EN 50085-1 a EN 50085-2-2

FLOOR BOX FLANGE MT 14 H=88mm

- floor box flange for box cover MT 14 H=88mm
- metal, galvanized
- for installation in a floor or double floor
- adjustable height 120-150mm
- in accordance with EN 50085-1 and EN 50085-2-2

PODLAHOVÁ KRABICA MT 21

RB36

- podlahová krabica MT 21
- kovová, farba strieborná RAL 9006
- montážne rámy MODUL 3 x 7M zabudované
- inštalčné rozmery 320 x 230mm, hĺbka min. 95 mm
- hrúbka podlahového obkladu krytu do 10 mm
- vyhovuje EN 50085-1 a EN 50085-2-2

FLOOR BOX MT 21

- floor box MT 21
- metal, colour silver RAL 9006
- mounting frames MODUL 3x7M included
- mounting dimensions 320x230mm, depth min 95mm
- floor lining thickness up to 10mm
- in accordance with EN 50085-1 and EN 50085-2-2

PODLAHOVÁ KRABICA MT 21 H=88 mm

RB46

- podlahová krabica MT 21
- kovová, farba strieborná RAL 9006
- montážne rámy MODUL 3 x 7M zabudované
- inštalčné rozmery 320 x 230mm, hĺbka min. 120 mm
- hrúbka podlahového obkladu krytu do 10 mm
- vyhovuje EN 50085-1 a EN 50085-2-2

FLOOR BOX MT 21 H=88mm

- floor box MT 21
- metal, colour silver RAL 9006
- mounting frames MODUL 3x7M included
- mounting dimensions 320x230mm, depth min 120mm
- floor lining thickness up to 10mm
- in accordance with EN 50085-1 and EN 50085-2-2

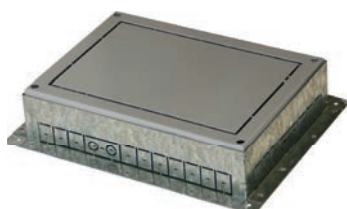
PODLOŽKA PODLAHOVEJ KRABICE MT 21

RB37

- podložka podlahovej krabice pre kryt MT 21
- kovová pozinkovaná
- na inštaláciu do podlahy alebo dvojitej podlahy
- nastaviteľná výška 95-125 mm
- vyhovuje EN 50085-1 a EN 50085-2-2

FLOOR BOX FLANGE MT 21

- floor box flange for box cover MT 21
- metal, galvanized
- for installation in a floor or double floor
- adjustable height 95-125mm
- in accordance with EN 50085-1 and EN 50085-2-2

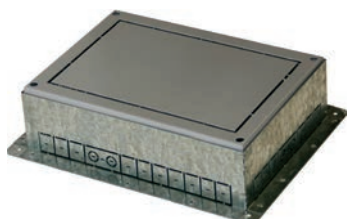
PODLOŽKA PODLAHOVEJ KRABICE MT 21 H=88 mm

RB47

- podložka podlahovej krabice pre kryt MT 21 H=88 mm
- kovová pozinkovaná
- na inštaláciu do podlahy alebo dvojitej podlahy
- nastaviteľná výška 120-150 mm
- vyhovuje EN 50085-1 a EN 50085-2-2

FLOOR BOX FLANGE MT 21 H=88mm

- floor box flange for box cover MT 21 H=88mm
- metal, galvanized
- for installation in a floor or double floor
- adjustable height 120-150mm
- in accordance with EN 50085-1 and EN 50085-2-2

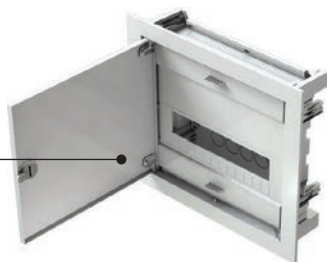
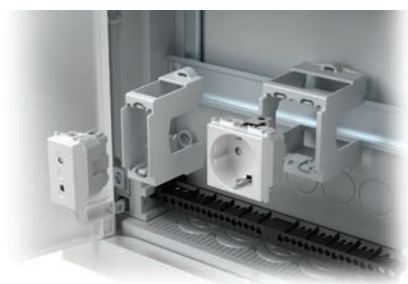

RB20

distribúcia

Typ type	názov description	technické údaje technical data
RB10	ADAPTÉR PRE DIN LIŠTU ADAPTER FOR DIN RAIL	35mm 1M
RB11	ADAPTÉR PRE DIN LIŠTU ADAPTER FOR DIN RAIL	35mm 2M
RB20	ROZVODNÁ SKRINKA DISTRIBUTION BOX	MO 12+2
.	.	.
.	.	.

ADAPTÉR PRE DIN LIŠTU 35 mm 1M



RB10

- adaptér MODUL 1M
- pre DIN lištu 35 mm
- vyhovuje EN50022

ADAPTER FOR DIN RAIL 35mm 1M
- adapter MODUL 1M
- for DIN rail 35mm
- in accordance with EN 50022

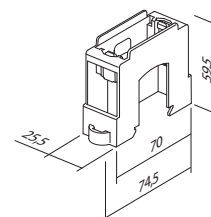

ADAPTÉR PRE DIN LIŠTU 35 mm 2M



RB11

- adaptér MODUL 2M
- pre DIN lištu 35 mm
- vyhovuje EN50022

ADAPTER FOR DIN RAIL 35mm 2M
- adapter MODUL 2M
- for DIN rail 35mm
- in accordance with EN 50022

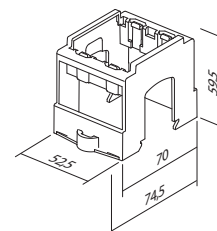

ROZVODNÁ SKRINKA MO 12 + 2



RB20

- rozvodná skrinka MO jednoradová 12 + 2MU
- 400V~, trieda ochrany II, IP40
- kovové dvierka a rámik, farba biela RAL 9016
- uzemňovacie a nulové svorky priložené
- univerzálna inštalácia do múru alebo dutej steny
- vyhovuje EN 60670-1 a IEC 60670-24

DISTRIBUTION BOX MO 12+2

- distribution box MO single row 12+2MU
- 400V~, Class II, IP40
- metal leveling frame and door, colour white RAL 9016
- neutral and earth conductor terminals enclosed
- universal for brick or hollow wall mounting
- in accordance with EN 60670-1 and IEC 60670-24

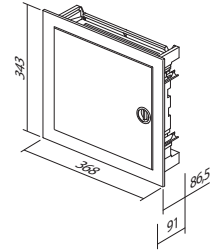

ROZVODNÁ SKRINKA MO 24+4



RB21

- rozvodová skrinka MO dvojradová 24 + 4 MU
- 400V~, trieda ochrany II, IP40
- kovové dvierka a rámik, farba biela RAL 9016
- uzemňovacie a nulové svorky priložené
- univerzálna inštalácia do múru alebo dutej steny
- vyhovuje EN 60670-1 a IEC 60670-24

DISTRIBUTION BOX MO 24+4

- distribution box MO double row 24+4MU
- 400V~, Class II, IP40
- metal leveling frame and door, colour white RAL 9016
- neutral and earth conductor terminals enclosed
- universal for brick or hollow wall mounting
- in accordance with EN 60670-1 and IEC 60670-24

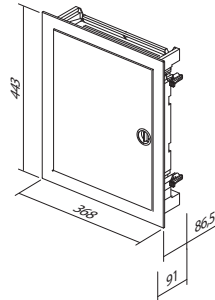

ROZVODNÁ SKRINKA MO 36 + 6



RB22

- rozvodová skrinka MO trojradová 36 + 6 MU
- 400V~, trieda ochrany II, IP40
- kovové dvierka a rámik, farba biela RAL 9016
- uzemňovacie a nulové svorky priložené
- univerzálna inštalácia do múru alebo dutej steny
- vyhovuje EN 60670-1 a IEC 60670-24

DISTRIBUTION BOX MO 36+6

- distribution box MO triple row 36+6 MU
- 400V~, Class II, IP40
- metal leveling frame and door, colour white RAL 9016
- neutral and earth conductor terminals enclosed
- universal for brick or hollow wall mounting
- in accordance with EN 60670-1 and IEC 60670-24

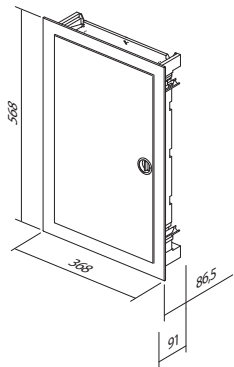

ROZVODNÁ SKRINKA MO 48 + 8



RB23

- rozvodová skrinka MO štvorradová 48 + 8 MU
- 400V~, trieda ochrany II, IP40
- kovové dvierka a rámik, farba biela RAL 9016
- uzemňovacie a nulové svorky priložené
- univerzálna inštalácia do múru alebo dutej steny
- vyhovuje EN 60670-1 a IEC 60670-24

DISTRIBUTION BOX MO 48+8

- distribution box MO quad row 48+8 MU
- 400V~, Class II, IP40
- metal leveling frame and door, colour white RAL 9016
- neutral and earth conductor terminals enclosed
- universal for brick or hollow wall mounting
- in accordance with EN 60670-1 and IEC 60670-24

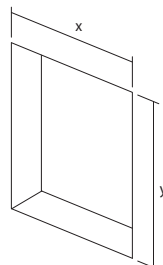
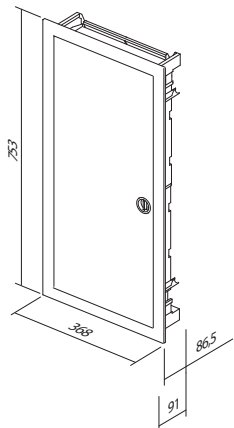

	RB20	RB21	RB22	RB23
x	314	314	314	314
y	314	414	539	724



ekonomik[®]



Planned for excellence
Style is essential



ERGONOMIA

KOV

MÄKKOSŤ

Neutrálny, kompaktný a elegantný dizajn sa prispôsobí každému obytnému alebo pracovnému prostrediu. V interiéroch sa nevyníma, ale harmonicky s nimi žije.

A neutral, compact, elegant design is adjustable to every working or living area. It does not stick out from the interior, but rather harmonically fits into it.





Navrhnuté pre dokonalosť Podstatný je štýl



Čistá línia je jemne zaoblená a premyslená ergonómia je navrhnutá osobitne pre Vás.

A pure line is slightly curved - well considered ergonomics especially for you.



Vybrať si môžete medzi lesklými reflexnými povrchmi a moderným kovovým vzhľadom.

You can choose between shiny reflective surfaces or a modern metallic look.



Mäkkosť tvaru nájde svoje miesto v moderných aj klasických interiéroch.

The softness of the form will find its place in modern as well as in classic interiors.

Požiadavky sú rozličné. Práve preto sme venovali veľkú pozornosť výberu možností, ktoré Vám poskytnú správnu odpoveď. Neutrálna paleta farieb iba doplní atmosféru miestnosti - nebude Vás obmedzovať.

Desires can be very different. Therefore we have carefully selected possibilities for you, which can offer you the right answer. A neutral palette of colours will only complement your ambient - it will not restrict it.

Press and the world will spring to life Colourful landscape between walls



Reflexné pocity Vám poskytnú lesklé polymérové materiály v bielej a perleťovo bielej (slonovej kosti) farbe.

Shiny polymer materials in white and beige colours enable reflective mood.



Moderný a neutrálny je aj vybraný dekoratívny kovový náter.

Selected decorative metallic coat is at the same time modern and neutral.

Stlačte a svet ožije

Farebná krajina medzi stenami



Pre všetkých, ktorí sa chcete pohrať s pastelovými farbami, je riešením Ekonomik Colour.

For those who want to play with pastel colours Ekonomik Colour represents a perfect solution.



Robusťnosť a vysoká odolnosť voči vonkajším vplyvom (UV) je zabezpečená prostredníctvom duroplastických materiálov (Colour).

Robustness and high resistance to external effects (UV) are secured by duroplastic materials (Colour line).



VERTIKÁLNE

HORIZONTÁLNE

ÚSPORA PRIESTORU



Kombinácie znamenajú úsporu miesta na stene. Keď máte málo miesta, je správnym rozhodnutím zvislá kombinácia.

With combining you save space on the wall. When faced with a limited space, "vertically" is the right decision.



Kombinujte podľa svojho želania.

Combine as you please.



Viditeľné prvky sa jednoducho demontujú. Vďační Vám budú aj maliari.

Visible elements can be easily taken apart. Painters will be grateful to you.



Prolong your day with a touch
Simplified living

Dotykom si predĺžime deň Zjednodušené bývanie

Ekonomik je riešenie pre systém štandardných okrúhlych krabíc. Pomocou nich môžete navrhnuť jednoduché a tiež náročnejšie inštalácie, novostavby aj adaptácie. Systém sa vyznačuje bezskrutkovými kontaktmi, ktoré Vám ušetria čas pri inštalácii jednotlivých prvkov.

Ekonomik is a solution for the system of standardized round installations boxes. It can be used for simple as well as more demanding installations, new buildings and adaptations. The system is characterised by plug-in contacts which save time during installation of elements.

Dobrý pocit v bezpečnom útulku

Absolútna dôvera v dobrú konštrukciu

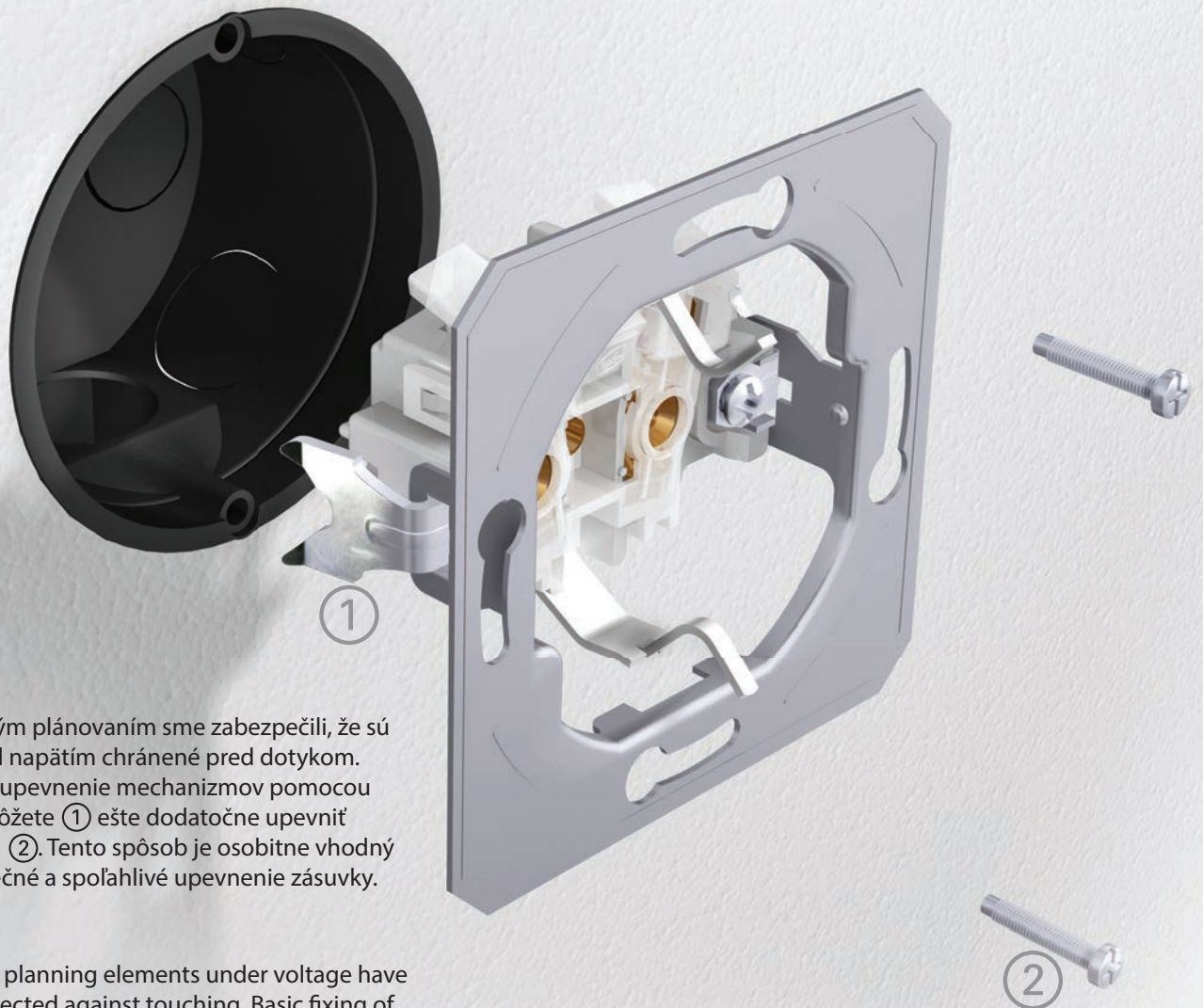

Starostlivým plánovaním sme zabezpečili, že sú prvky pod napätím chránené pred dotykom. Základné upevnenie mechanizmov pomocou svoriek môžete ① ešte dodatočne upevniť skrutkami ②. Tento spôsob je osobitne vhodný pre bezpečné a spoľahlivé upevnenie zásuvky.

By careful planning elements under voltage have been protected against touching. Basic fixing of mechanisms with fixing claws ① allows additional strengthening with screws ②. This manner is especially appropriate for safe and reliable fixing of sockets.

JEDNODUCHO

RÝCHLO

FLEXIBILNE



Dobre premyslená konštrukcia spínača umožňuje jednoduché osvetlenie aj dodatočne.

A well-planned switch construction makes easy illumination possible also subsequently.

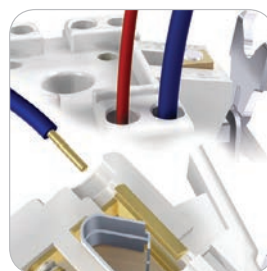

Bezskrutkové kontakty umožňujú rýchle a spoľahlivé pripojenie vodičov. Na ten istý kontakt môžete upevniť dva vodiče rozličných priemerov.

Plug-in contacts enable quick and reliable attachment of wires. Two wires of different diameters can be attached to the same contact.

Kombinovateľné krabice Vám uľahčia prácu. Správne vzdialenosti sú zaistené.

Easy-fitting installation boxes will make your work easier. Proper lengths are guaranteed.



Feeling well in a safe shelter Total confidence in a good construction

BEZPEČNÉ

DÔVERYHODNÉ

PRESKÚŠANÉ

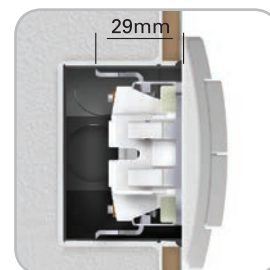

Svorky umožňujú hlbšie upevnenie (aj cez keramické obkladačky a pod.)

Fixing claws enable deeper fixing (also through ceramic tiles, etc.)



Všetky spínače majú zreteľnú identifikáciu na zadnej strane.

All switches have a clear identification in the back.

Spínače sú testované podľa medzinárodných štandardov, ktoré zabezpečujú bezpečnosť a dlhú životnosť.

Switches were tested according to international standards which guarantee safety and long life span.



Spoľahlivosť prepnutia zabezpečujú kontakty zo striebornej zliatiny (AgNi).

Contacts made of silver alloy (Ag-Ni) guarantee safe switching.

TEM





SPÍNAČE SE SWITCHES SE		164
TLAČIDLÁ TE BUTTONS TE		168
OSVETLENIE IA ILLUMINATION IA		169
ZÁSUVKY VE SOCKETS VE		171
KOMUNIKÁCIE KE COMMUNICATIONS KE		175
KRYTY PE COVERS PE		179
ELEKTRONIKA EE ELECTRONICS EE		180
PRÍSLUŠENSTVO AE ACCESSORIES AE		184
RÁMIKY OE SURROUNDS OE		186

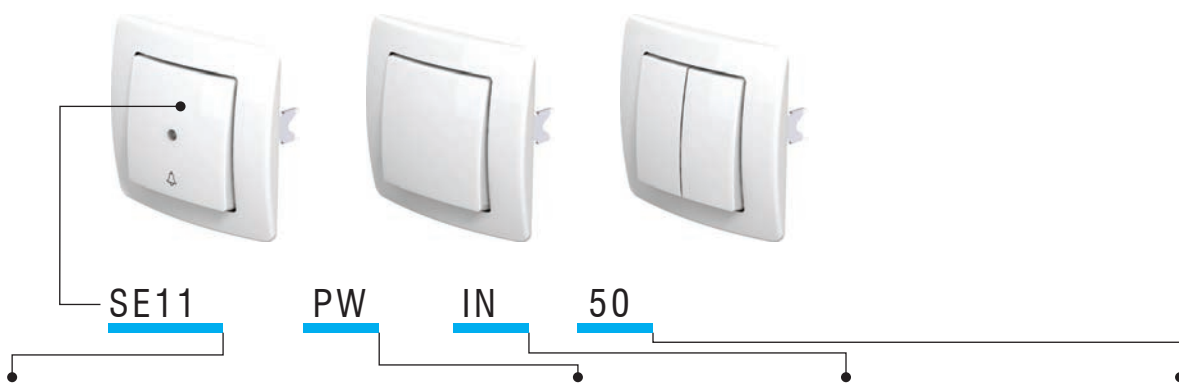

Typ type	názov description	technické údaje technical data	farba colour	fakultatívny opis 1 optional data 1	fakultatívny opis 2 optional data 2
SE10	SPÍNAČ JEDNOPÓLOVÝ SWITCH 1WAY	10AX 250V~	<input type="checkbox"/> PW biely-lesklý polar white	NT neutrál neutral	50
SE11	SPÍNAČ JEDNOPÓLOVÝ PUSH BUTTON 1WAY	10A 250V~	<input type="checkbox"/> IW slonová kosť-lesklý ivory white		51
SE22	SPÍNAČ DVOJPÓLOVÝ SWITCH 2POLE	16AX 250V~	<input type="checkbox"/> ES strieborný-matný elox silver	IN indikátor indication	03
..	<input type="checkbox"/> CO biely duroplast white thermoset		04
..	<input type="checkbox"/> NB čierny-lesklý night black		..

SPÍNAČ JEDNOPÓLOVÝ 10AX 250V~

SE10

- 10AX 250V~, typ SE10
- vyhovuje EN 60669-1
- bezskrútkové upevnenie vodičov 1,5-2,5 mm²

SWITCH 1WAY 10AX 250V~

- 10AX 250V~, type SE10
- in accordance with EN 60669-1
- plug-in contacts 1.5-2.5mm²

SPÍNAČ JEDNOPÓLOVÝ 10A 250V~

SE11

- 10A 250V~, typ SE11
- vyhovuje EN 60669-1
- bezskrútkové upevnenie vodičov 1,5-2,5 mm²

PUSH BUTTON 1WAY 10A 250V~

- 10A 250V~, type SE11
- in accordance with EN 60669-1
- plug-in contacts 1.5-2.5mm²

SPÍNAČ DVOJPÓLOVÝ 16AX 250V~

SE22

- 16AX 250V~, typ SE22
- vyhovuje EN 60669-1
- skrútkové upevnenie vodičov 1,5 – 2,5 mm²
- len v kombinácii s krytkou tlačidla TE10__NT03

SWITCH 2POLE 16AX 250V~

- 16AX 250V~, type SE22
- in accordance with EN 60669-1
- screw contacts 1.5-2.5mm²
- only in combination with button TE10__NT03

SPÍNAČ SÉRIOVÝ 10AX 250V~

SE50

- 10AX 250V~, typ SE50
- vyhovuje EN 60669-1
- bezskrútkové upevnenie vodičov 1,5-2,5 mm²

SWITCH 2GANG-1WAY 10AX 250V~

- 10AX 250V~, type SE50
- in accordance with EN 60669-1
- plug-in contacts 1.5-2.5mm²

SPÍNAČ SÉRIOVÝ 10A 250V~



SE51

- 10A 250V~, typ SE51
- vyhovuje EN 60669-1
- bezskrútkové upevnenie vodičov 1,5-2,5 mm²

PUSH BUTTON 2GANG-1WAY 10A 250V~

- 10A 250V~, type SE51
- in accordance with EN 60669-1
- plug-in contacts 1.5-2.5mm²

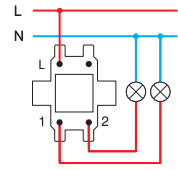
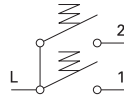

SPÍNAČ ŽALÚZIOVÝ 10AX 250V~



SE52

- 10AX 250V~, typ SE52
- vyhovuje EN 60669-1
- bezskrútkové upevnenie vodičov 1,5-2,5mm²
- s mechanickou blokadou súčasného zapnutia

SWITCH SHUTTERS 10AX 250V~

- 10AX 250V~, type SE52
- in accordance with EN 60669-1
- plug-in contacts 1.5-2.5mm²
- with mechanical interlock

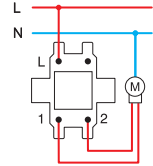
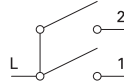

SPÍNAČ ŽALÚZIOVÝ 10A 250V~



SE53

- 10A 250V~, typ SE53
- vyhovuje EN 60669-1
- bezskrútkové upevnenie vodičov 1,5-2,5 mm²
- s mechanickou blokadou súčasného zapnutia

PUSH BUTTON SHUTTERS 10A 250V~

- 10A 250V~, type SE53
- in accordance with EN 60669-1
- plug-in contacts 1.5-2.5mm²
- with mechanical interlock

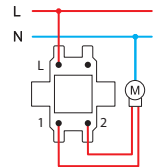
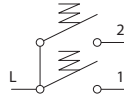

SPÍNAČ STRIEDAVÝ 10AX 250V~



SE60

- 10AX 250V~, typ SE60
- vyhovuje EN 60669-1
- bezskrútkové upevnenie vodičov 1,5-2,5mm²

SWITCH 2WAY 10AX 250V~

- 10AX 250V~, type SE60
- in accordance with EN 60669-1
- plug-in contacts 1.5-2.5mm²

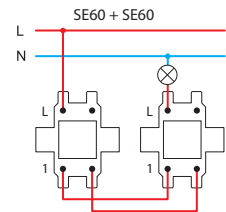
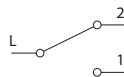

SPÍNAČ DVOJITÝ STRIEDAVÝ 10AX 250V~



SE63

- 10AX 250V~, typ SE63
- vyhovuje EN 60669-1
- bezskrútkové upevnenie vodičov 1,5-2,5 mm²

SWITCH DOUBLE 2WAY 10AX 250V~

- 10AX 250V~, type SE63
- in accordance with EN 60669-1
- plug-in contacts 1.5-2.5mm²

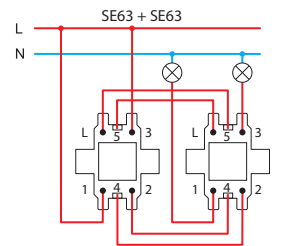

SPÍNAČ KRÍŽOVÝ 10AX 250V~



SE70

- 10AX 250V~, typ SE70
- vyhovuje EN 60669-1
- bezskrútkové upevnenie vodičov 1,5-2,5 mm²

SWITCH INTERMEDIATE 10AX 250V~

- 10AX 250V~, type SE70
- in accordance with EN 60669-1
- plug-in contacts 1.5-2.5mm²

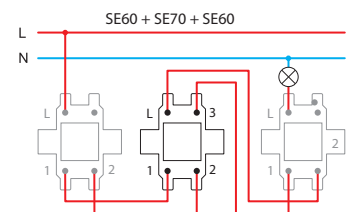

SPÍNAČ JEDNOPÓLOVÝ 10AX 250V~



- SE10PW
- SE10IW
- SE10ES
- SE10CO
- SE10NB

- 10AX 250V~, typ SE10
 - vyhovuje EN 60669-1
 - bezskrútkové upevnenie vodičov 1,5-2,5 mm²
SWITCH 1WAY 10AX 250V~
 - 10AX 250V~, type SE10
 - in accordance with EN 60669-1
 - plug-in contacts 1.5-2.5mm²



SPÍNAČ JEDNOPÓLOVÝ 10AX 250V~ __ IN



- SE10PWIN
- SE10IWIN
- SE10ESIN
- SE10COIN
- SE10NBIN

- IN indikátor
 - 10AX 250V~, typ SE10
 - vyhovuje EN 60669-1
 - bezskrútkové upevnenie vodičov 1,5-2,5 mm²
SWITCH 1WAY 10AX 250V~ __ IN
 - IN indicator
 - 10AX 250V~, type SE10
 - in accordance with EN 60669-1
 - plug-in contacts 1.5-2.5mm²



SPÍNAČ JEDNOPÓLOVÝ 10A 250V~



- SE11PW
- SE11IW
- SE11ES
- SE11CO
- SE11NB

- 10A 250V~, typ SE11
 - vyhovuje EN 60669-1
 - bezskrútkové upevnenie vodičov 1,5-2,5 mm²
PUSH BUTTON 1WAY 10A 250V~
 - 10A 250V~, type SE11
 - in accordance with EN 60669-1
 - plug-in contacts 1.5-2.5mm²



SPÍNAČ JEDNOPÓLOVÝ 10A 250V~ __ TI 50



- SE11PWTI50
- SE11IWTI50
- SE11ESTI50
- SE11COTI50
- SE11NBTI50

- TI 50 indikátor zvonec + výbojka
 - 10A 250V~, typ SE11
 - vyhovuje EN 60669-1
 - bezskrútkové upevnenie vodičov 1,5-2,5 mm²
PUSH BUTTON 1WAY 10A 250V~ __ TI 50
 - TI 50 indicator bell+neon lamp
 - 10A 250V~, type SE11
 - in accordance with EN 60669-1
 - plug-in contacts 1.5-2.5mm²



SPÍNAČ JEDNOPÓLOVÝ 10A 250V~ __ TI 51



- SE11PWTI51
- SE11IWTI51
- SE11ESTI51
- SE11COTI51
- SE11NBTI51

- TI 51 indikátor osvetlenie + výbojka
 - 10A 250V~, typ SE11
 - vyhovuje EN 60669-1
 - bezskrútkové upevnenie vodičov 1,5-2,5 mm²
PUSH BUTTON 1WAY 10A 250V~ __ TI 51
 - TI 51 indicator light+neon lamp
 - 10A 250V~, type SE11
 - in accordance with EN 60669-1
 - plug-in contacts 1.5-2.5mm²



SPÍNAČ JEDNOPÓLOVÝ 10A 250V~ __ IL



- SE11PWIL
- SE11IWIL
- SE11ESIL
- SE11COIL
- SE11NBIL

- IL nápisový štítok
 - 10A 250V~, typ SE11
 - vyhovuje EN 60669-1
 - bezskrútkové upevnenie vodičov 1,5-2,5 mm²
PUSH BUTTON 1WAY 10A 250V~ __ IL
 - IL inscription plate
 - 10A 250V~, type SE11
 - in accordance with EN 60669-1
 - plug-in contacts 1.5-2.5mm²



SPÍNAČ DVOJPÓLOVÝ 16AX 250V~ __ NT 03



- SE22PWNT03
- SE22IWNT03
- SE22ESNT03
- SE22NBNT03

- NT 03 neutrál 0-1
 - 16AX 250V~, typ SE22
 - vyhovuje EN 60669-1
 - skrútkové upevnenie vodičov 1,5-2,5 mm²
SWITCH 2POLE 16AX 250V~ __ NT 03
 - NT 03 neutral 0-1
 - 16AX 250V~, type SE22
 - in accordance with EN 60669-1
 - screw contacts 1.5-2.5mm²



	<ul style="list-style-type: none"> <input type="checkbox"/> SE50PW <input type="checkbox"/> SE50IW <input type="checkbox"/> SE50ES <input type="checkbox"/> SE50CO <input type="checkbox"/> SE50NB 	<p>SPÍNAČ SÉRIOVÝ 10AX 250V~</p> <ul style="list-style-type: none"> - 10AX 250V~, typ SE50 - vyhovuje EN 60669-1 - bezskrútkové upevnenie vodičov 1,5-2,5 mm² <p><i>SWITCH 2GANG-1WAY 10AX 250V~</i></p> <ul style="list-style-type: none"> - 10AX 250V~, type SE50 - in accordance with EN 60669-1 - plug-in contacts 1.5-2.5mm² 	
	<ul style="list-style-type: none"> <input type="checkbox"/> SE51PW <input type="checkbox"/> SE51IW <input type="checkbox"/> SE51ES <input type="checkbox"/> SE51CO <input type="checkbox"/> SE51NB 	<p>SPÍNAČ SÉRIOVÝ 10A 250V~</p> <ul style="list-style-type: none"> - 10A 250V~, typ SE51 - vyhovuje EN 60669-1 - bezskrútkové upevnenie vodičov 1,5-2,5 mm² <p><i>PUSH BUTTON 2GANG-1WAY 10A 250V~</i></p> <ul style="list-style-type: none"> - 10A 250V~, type SE51 - in accordance with EN 60669-1 - plug-in contacts 1.5-2.5mm² 	
	<ul style="list-style-type: none"> <input type="checkbox"/> SE52PWNT09 <input type="checkbox"/> SE52IWNT09 <input type="checkbox"/> SE52ESNT09 <input type="checkbox"/> SE52CONT09 <input type="checkbox"/> SE52NBNT09 	<p>SPÍNAČ ŽALÚZIOVÝ 10AX 250V~ __ NT 09</p> <ul style="list-style-type: none"> - NT 09 neutrál hore -dole - 10AX 250V~, typ SE52 - vyhovuje EN 60669-1 - bezskrútkové upevnenie vodičov 1,5-2,5 mm² - s mechanickou blokadou súčasného zapnutia <p><i>SWITCH SHUTTERS 10AX 250V~ __ NT 09</i></p> <ul style="list-style-type: none"> - NT 09 neutral up-down - 10AX 250V~, type SE52 - in accordance with EN 60669-1 - plug-in contacts 1.5-2.5mm² - with mechanical interblock 	
	<ul style="list-style-type: none"> <input type="checkbox"/> SE53PWNT09 <input type="checkbox"/> SE53IWNT09 <input type="checkbox"/> SE53ESNT09 <input type="checkbox"/> SE53CONT09 <input type="checkbox"/> SE53NBNT09 	<p>SPÍNAČ ŽALÚZIOVÝ 10A 250V~ __NT 09</p> <ul style="list-style-type: none"> - NT 09 neutrál hore -dole - 10A 250V~, typ SE53 - vyhovuje EN 60669-1 - bezskrútkové upevnenie vodičov 1,5-2,5 mm² - s mechanickou blokadou súčasného zapnutia <p><i>PUSH BUTTON SHUTTERS 10A 250V~ __NT 09</i></p> <ul style="list-style-type: none"> - NT 09 neutral up-down - 10A 250V~, type SE53 - in accordance with EN 60669-1 - plug-in contacts 1.5-2.5mm² - with mechanical interblock 	
	<ul style="list-style-type: none"> <input type="checkbox"/> SE60PW <input type="checkbox"/> SE60IW <input type="checkbox"/> SE60ES <input type="checkbox"/> SE60CO <input type="checkbox"/> SE60NB 	<p>SPÍNAČ STRIEDAVÝ 10AX 250V~</p> <ul style="list-style-type: none"> - 10AX 250V~, typ SE60 - vyhovuje EN 60669-1 - bezskrútkové upevnenie vodičov 1,5-2,5 mm² <p><i>SWITCH 2WAY 10AX 250V~</i></p> <ul style="list-style-type: none"> - 10AX 250V~, type SE60 - in accordance with EN 60669-1 - plug-in contacts 1.5-2.5mm² 	
	<ul style="list-style-type: none"> <input type="checkbox"/> SE63PW <input type="checkbox"/> SE63IW <input type="checkbox"/> SE63ES <input type="checkbox"/> SE63CO <input type="checkbox"/> SE63NB 	<p>SPÍNAČ DVOJITÝ STRIEDAVÝ 10AX 250V~</p> <ul style="list-style-type: none"> - 10AX 250V~, typ SE63 - vyhovuje EN 60669-1 - bezskrútkové upevnenie vodičov 1,5-2,5 mm² <p><i>SWITCH DOUBLE 2WAY 10AX 250V~</i></p> <ul style="list-style-type: none"> - 10AX 250V~, type SE63 - in accordance with EN 60669-1 - plug-in contacts 1.5-2.5mm² 	
	<ul style="list-style-type: none"> <input type="checkbox"/> SE70PW <input type="checkbox"/> SE70IW <input type="checkbox"/> SE70ES <input type="checkbox"/> SE70CO <input type="checkbox"/> SE70NB 	<p>SPÍNAČ KRÍŽOVÝ 10AX 250V~</p> <ul style="list-style-type: none"> - 10AX 250V~, typ SE70 - vyhovuje EN 60669-1 - bezskrútkové upevnenie vodičov 1,5-2,5 mm² <p><i>SWITCH INTERMEDIATE 10AX 250V~</i></p> <ul style="list-style-type: none"> - 10AX 250V~, type SE70 - in accordance with EN 60669-1 - plug-in contacts 1.5-2.5mm² 	

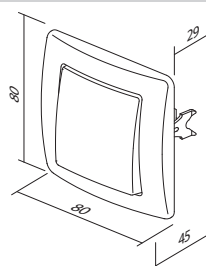
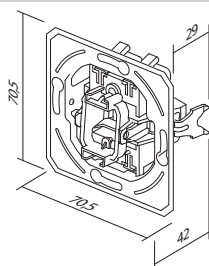

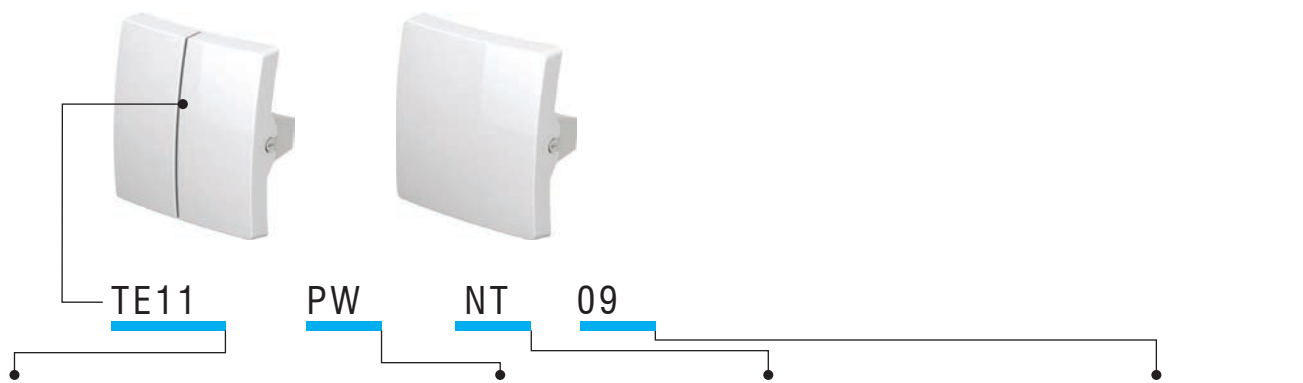

Typ type	názov description	farba colour	fakultatívny opis 1 optional data 1	fakultatívny opis 2 optional data 2
TE10	KRYTKA OBYČAJNÁ BUTTON 1GANG	<input type="checkbox"/> PW biely-lesklý polar white <input type="checkbox"/> IW slonová kosť-lesklý ivory white <input type="checkbox"/> ES strieborný-matný elox silver <input type="checkbox"/> CO biely duroplast white thermoset <input type="checkbox"/> NB čierny-lesklý night black	NT neutrál neutral IN indikátor indication	50 51 03 04
TE11	KRYTKA SÉRIOVÁ BUTTON 2GANG			

KRYTKA NA SPÍNAČ OBYČAJNÁ



- TE10PW
- TE10IW
- TE10ES
- TE10CO
- TE10NB

- krytka na spínač s montážnym rámkom
BUTTON 1GANG
- button together with carrier



KRYTKA NA SPÍNAČ INDIKÁTOR



- TE10PWIN
- TE10IWIN
- TE10ESIN
- TE10COIN
- TE10NBIN

- krytka na spínač s montážnym rámkom
BUTTON INDICATOR
- button together with carrier



KRYTKA NA SPÍNAČ S POPISNÝM ŠTÍTKOM



- TE13PWIL
- TE13IWIL
- TE13ESIL
- TE13COIL
- TE13NBIL

- krytka na spínač s montážnym rámkom, s popisným štítkom
BUTTON WITH INSCRIPTION PLATE
- button together with carrier, with inscription plate



KRYTKA NA SPÍNAČ SÉRIOVÁ



- TE11PW
- TE11IW
- TE11ES
- TE11CO
- TE11NB

- krytka na spínač sériová s montážnym rámkom
BUTTON 2GANG
- button 2gang together with carrier

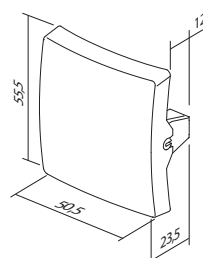
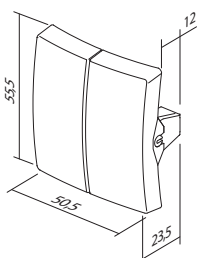

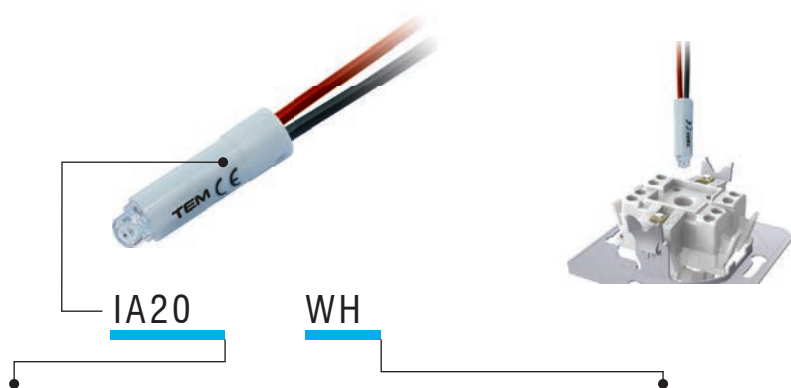

Typ type	názov description	technické údaje technical data	farba colour
IA10	VÝBOJKA NEON LAMP	230V~ 0,34W	<input type="checkbox"/> WH biela white
IA20	ŽIARIVKA LED LED LAMP	230V~ 0,40W	<input checked="" type="checkbox"/> BL modrá blue
IA21	ŽIARIVKA LED LED LAMP	24V AC/DC 0,20W	<input checked="" type="checkbox"/> RD červená red
.	.	.	<input checked="" type="checkbox"/> GR zelená green
.	.	.	<input checked="" type="checkbox"/> OR oranžová orange

VÝBOJKA 230V~ 0,34W

 IA10OR

- na indikáciu, osvetlenie alebo trvalé osvetlenie spínača
- v kombinácii s tlačidlom s indikátorom

NEON LAMP 230V~ 0,34W

- for indication, illumination or constant illumination of switch
- in combination with button with indicator

ŽIARIVKA LED 230V AC/DC 0,40W

 IA20WH
 IA20GR
 IA20RD
 IA20BL

- na indikáciu, osvetlenie alebo trvalé osvetlenie spínača
- v kombinácii s tlačidlom s indikátorom

LED LAMP 230V AC/DC 0,40W

- for indication, illumination or constant illumination of switch
- in combination with button with indicator

ŽIARIVKA LED 24V AC/DC 0,20W

 IA21RD

- na indikáciu, osvetlenie alebo trvalé osvetlenie spínača
- v kombinácii s tlačidlom s indikátorom

LED LAMP 24V AC/DC 0,20W

- for indication, illumination or constant illumination of switch
- in combination with button with indicator

ŽIARIVKA LED 12V AC/DC 0,10W

 IA22RD

- na indikáciu, osvetlenie alebo trvalé osvetlenie spínača
- v kombinácii s tlačidlom s indikátorom

LED LAMP 12V AC/DC 0,10W

- for indication, illumination or constant illumination of switch
- in combination with button with indicator

Indikácia / *
Indication

Podsvietenie /
Illumination

Trvalé osvetlenie / *
Illumination always on

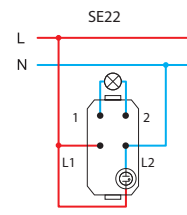
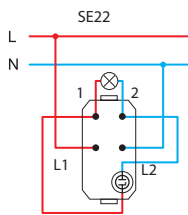
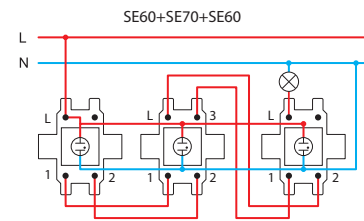
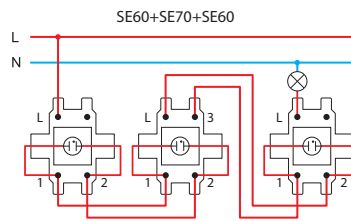
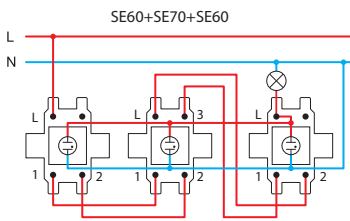
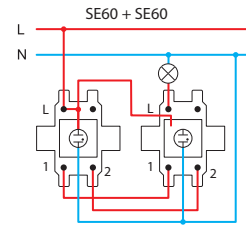
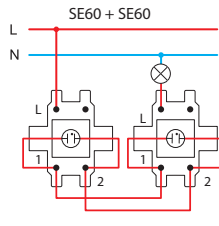
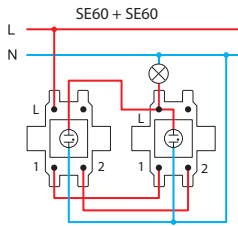
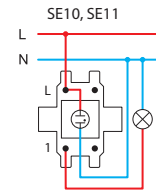
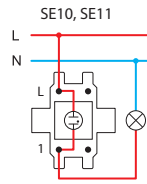
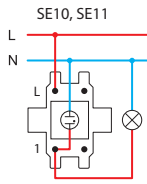

* spojenia vhodné pre úsporné (CFL) žiarivky / wiring schemes for compact fluid lamp (CFL)

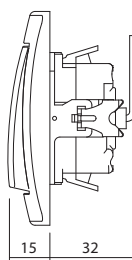

S O C K E T S V E

VE11 **PT** **XO** **KS**

Typ type	názov description	technické údaje technical data	farba colour	fakultatívny opis 1 optional data 1	fakultatívny opis 2 optional data 2
VE10	ZÁSUVKA SCHUKO SOCKET SCHUKO	2P+E 16A 250V~		XO bez rámy without cover plate	KS detská ochrana child protection
VE11	ZÁSUVKA SCHUKO+KRYT SOCKET SCHUKO+COVER	2P+E 16A 250V~			
VE12	ZÁSUVKA SCHUKO SOCKET SCHUKO	2P+E 16A 250V~ BV		KS detská ochrana child protection	
.	.	.	.		
.	.	.	.		

farba
colour

<input type="checkbox"/> PW biely-lesklý polar white	<input checked="" type="checkbox"/> PT biela + transparentná white+transparent	<input type="checkbox"/> PP biela + biela white+white
<input checked="" type="checkbox"/> IW slonová kosť-lesklý ivory white	<input checked="" type="checkbox"/> IT slonová kosť + transparentná ivory+transparent	<input checked="" type="checkbox"/> II slonová kosť + slonová kosť ivory+ivory
<input type="checkbox"/> ES strieborný-matný elox silver	<input checked="" type="checkbox"/> ST strieborná + transparentná silver+transparent	<input type="checkbox"/> SS strieborná + strieborná silver+silver
<input type="checkbox"/> CO biely duroplast white thermoset	<input checked="" type="checkbox"/> CT biela + transparentná white+transparent	<input type="checkbox"/> BB čierna + čierna black+black
<input checked="" type="checkbox"/> NB čierny-lesklý night black	<input checked="" type="checkbox"/> BT čierna + transparentná black+transparent	<input checked="" type="checkbox"/> RR červená + červená red+red
<input checked="" type="checkbox"/> RD červená red	<input checked="" type="checkbox"/> RT červená + transparentná red+transparent	<input checked="" type="checkbox"/> GG zelená + zelená green+green
<input checked="" type="checkbox"/> GR zelená green	<input checked="" type="checkbox"/> GT zelená + transparentná green+transparent	<input checked="" type="checkbox"/> OO oranžová + oranžová orange+orange
<input checked="" type="checkbox"/> OR oranžová orange	<input checked="" type="checkbox"/> OT oranžová + transparentná orange+transparent	



schuko - vyhovuje EN 60884-1, CEE7 (list III)

schuko - in accordance with EN 60884-1, CEE7 (standard sheet III)

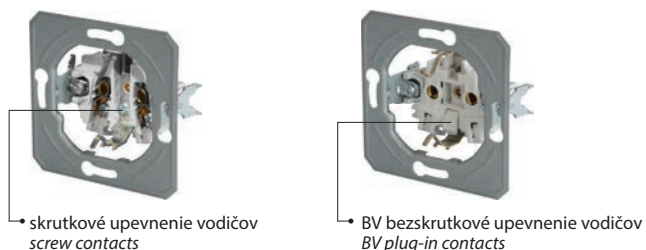

Francúzsko - vyhovuje NF C 61-314 (list V)

French - in accordance with NF C 61-314 (standard sheet V)

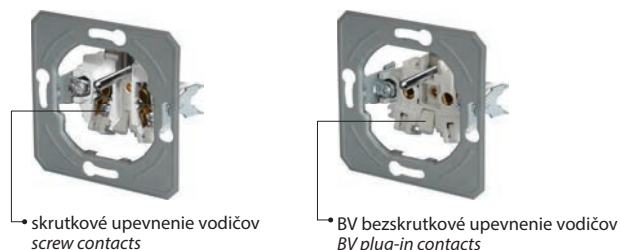

ZÁSUVKA SCHUKO 2P+E 16A 250V~ __ XO



- VE10PWXO - skrutkové upevnenie vodičov 1,5-2,5 mm²
- VE10IWXO - XO bez rámy
- VE10ESXO - 2P+E schuko
- VE10COXO - 16A 250V~, typ VE10
- VE10NBXO *SOCKET SCHUKO 2P+E 16A 250V~ __ XO*
- VE10RDXO - screw contacts 1.5-2.5mm²
- VE10GRXO - XO without surround
- VE10ORXO - 2P+E schuko
- VE10ORXO - 16A 250V~, type VE10



ZÁSUVKA SCHUKO+KRYT 2P+E 16A 250V~ __ XO



- VE11PTXO - skrutkové upevnenie vodičov 1,5-2,5 mm²
- VE11ITXO - XO bez rámy
- VE11STXO - 2P+E schuko+kryt
- VE11BTXO - 16A 250V~, typ VE11
- SOCKET SCHUKO+COVER 2P+E 16A 250V~ __ XO*
- screw contacts 1.5-2.5mm²
- XO without surround
- 2P+E schuko+cover
- 16A 250V~, type VE11



ZÁSUVKA SCHUKO 2P+E 16A 250V~ BV __ XO



- VE12PWXO - BV bezskrutkové upevnenie vodičov 1,5-2,5 mm²
- VE12IWXO - XO bez rámy
- VE12ESXO - 2P+E schuko
- VE12COXO - 16A 250V~, typ VE12
- VE12NBXO *SOCKET SCHUKO 2P+E 16A 250V~ BV __ XO*
- VE12RDXO - BV plug-in contacts 1.5-2.5mm²
- VE12GRXO - XO without surround
- VE12ORXO - 2P+E schuko
- VE12ORXO - 16A 250V~, type VE12



ZÁSUVKA SCHUKO+KRYT 2P+E 16A 250V~ BV __ XO



- VE13PTXO - BV bezskrutkové upevnenie vodičov 1,5-2,5 mm²
- VE13ITXO - XO bez rámy
- VE13STXO - 2P+E schuko+kryt
- VE13BTXO - 16A 250V~, typ VE13
- VE13PPXO *SOCKET SCHUKO+COVER 2P+E 16A 250V~ BV __ XO*
- BV plug-in contacts 1.5-2.5mm²
- XO without surround
- 2P+E schuko+cover
- 16A 250V~, type VE13



ZÁSUVKA SCHUKO 2P+E 16A 250V~



- VE10PW - skrutkové upevnenie vodičov 1,5-2,5 mm²
- VE10IW - 2P+E schuko
- VE10ES - 16A 250V~, typ VE10
- VE10CO *SOCKET SCHUKO 2P+E 16A 250V~*
- VE10NB - screw contacts 1.5-2.5mm²
- VE10NB - 2P+E schuko
- VE10NB - 16A 250V~, type VE10



ZÁSUVKA SCHUKO+KRYT 2P+E 16A 250V~



- VE11PT - skrutkové upevnenie vodičov 1,5-2,5 mm²
- VE11IT - 2P+E schuko+kryt
- VE11ST - 16A 250V~, typ VE11
- VE11CT *SOCKET SCHUKO+COVER 2P+E 16A 250V~*
- VE11BT - screw contacts 1.5-2.5mm²
- VE11BT - 2P+E schuko+cover
- VE11BT - 16A 250V~, type VE11



ZÁSUVKA SCHUKO 2P+E 16A 250V~ BV



- VE12PW - BV bezskrutkové upevnenie vodičov 1,5-2,5 mm²
- VE12IW - 2P+E schuko
- VE12ES - 16A 250V~, typ VE12
- VE12CO *SOCKET SCHUKO 2P+E 16A 250V~ BV*
- VE12NB - BV plug-in contacts 1.5-2.5mm²
- VE12NB - 2P+E schuko
- VE12NB - 16A 250V~, type VE12



ZÁSUVKA SCHUKO+KRYT 2P+E 16A 250V~ BV



- VE13PT - BV bezskrutkové upevnenie vodičov 1,5-2,5 mm²
- VE13IT - 2P+E schuko+kryt
- VE13ST - 16A 250V~, typ VE13
- VE13CT *SOCKET SCHUKO+COVER 2P+E 16A 250V~ BV*
- VE13BT - BV plug-in contacts 1.5-2.5mm²
- VE13BT - 2P+E schuko+cover
- VE13BT - 16A 250V~, type VE13



ZÁSUVKA FRANCÚZSKA 2P+E 16A 250V~ __ XO



- VE40PWXO
- VE40IWXO
- VE40ESXO
- VE40COXO
- VE40NBXO
- VE40RDXO
- VE40GRXO
- VE40ORXO

- skrutkové upevnenie vodičov 1,5-2,5mm²
- XO bez rámy
- 2P+E francúzska
- 16A 250V~, typ VE40

SOCKET FRENCH 2P+E 16A 250V~ __ XO

- screw contacts 1.5-2.5mm²
- XO without surround
- 2P+E French
- 16A 250V~, type VE40



ZÁSUVKA FRANCÚZSKA + KRYT 2P+E 16A 250V~ __ XO



- VE41PTXO
- VE41ITXO
- VE41STXO
- VE41PTXO
- VE41BTXO
- VE41PPXO

- skrutkové upevnenie vodičov 1,5-2,5mm²
- XO bez rámy
- 2P+E francúzska + kryt
- 16A 250V~, typ VE41

SOCKET FRENCH+COVER 2P+E 16A 250V~ __ XO

- screw contacts 1.5-2.5mm²
- XO without surround
- 2P+E French+cover
- 16A 250V~, type VE41



ZÁSUVKA FRANCÚZSKA 2P+E 16A 250V~ BV __ XO



- VE42PWXO
- VE42IWXO
- VE42ESXO
- VE42COXO
- VE42NBXO
- VE42RDXO
- VE42GRXO
- VE42ORXO

- BV bezskrutkové upevnenie vodičov 1,5-2,5mm²
- XO bez rámy
- 2P+E francúzska
- 16A 250V~, typ VE42

SOCKET FRENCH 2P+E 16A 250V~ BV __ XO

- BV plug-in contacts 1.5-2.5mm²
- XO without surround
- 2P+E French
- 16A 250V~, type VE42



ZÁSUVKA FRANCÚZSKA + KRYT 2P+E 16A 250V~ BV __ XO



- VE43PTXO
- VE43ITXO
- VE43STXO
- VE43PTXO
- VE43BTXO
- VE43PPXO

- BV bezskrutkové upevnenie vodičov 1,5-2,5 mm²
- XO bez rámy
- 2P+E francúzska + kryt
- 16A 250V~, typ VE43

SOCKET FRENCH+COVER 2P+E 16A 250V~ BV __ XO

- BV plug-in contacts 1.5-2.5mm²
- XO without surround
- 2P+E French+cover
- 16A 250V~, type VE43



ZÁSUVKA FRANCÚZSKA 2P+E 16A 250V~



- VE40PW
- VE40IW
- VE40ES
- VE40CO
- VE40NB

- skrutkové upevnenie vodičov 1,5-2,5 mm²
- 2P+E francúzska
- 16A 250V~, typ VE40

SOCKET FRENCH 2P+E 16A 250V~

- screw contacts 1.5-2.5mm²
- 2P+E French
- 16A 250V~, type VE40



ZÁSUVKA FRANCÚZSKA + KRYT 2P+E 16A 250V~



- VE41PT
- VE41IT
- VE41ST
- VE41CT
- VE41BT

- skrutkové upevnenie vodičov 1,5-2,5 mm²
- 2P+E francúzska + kryt
- 16A 250V~, typ VE41

SOCKET FRENCH+COVER 2P+E 16A 250V~

- screw contacts 1.5-2.5mm²
- 2P+E French+cover
- 16A 250V~, type VE41



ZÁSUVKA FRANCÚZSKA 2P+E 16A 250V~ BV



- VE42PW
- VE42IW
- VE42ES
- VE42CO
- VE42NB

- BV bezskrutkové upevnenie vodičov 1,5-2,5 mm²
- 2P+E francúzska
- 16A 250V~, typ VE42

SOCKET FRENCH 2P+E 16A 250V~ BV

- BV plug-in contacts 1.5-2.5mm²
- 2P+E French
- 16A 250V~, type VE42



ZÁSUVKA FRANCÚZSKA + KS + KRYT 2P+E 16A 250V~ BV



- VE43PT
- VE43IT
- VE43ST
- VE43CT
- VE43BT

- BV bezskrutkové upevnenie vodičov 1,5-2,5 mm²
- 2P+E francúzska + kryt
- 16A 250V~, typ VE43

SOCKET FRENCH+COVER 2P+E 16A 250V~ BV

- BV plug-in contacts 1.5-2.5mm²
- 2P+E French+cover
- 16A 250V~, type VE43



ZÁSUVKA SCHUKO DVOJITÁ 2P+E 16 A 250 V ~



- VE16PW
- VE16IW
- VE16ES
- VE16NB

- 2P+E schuko dvojité
- 16 A 250 V ~, typ VE16
- vyhovuje IEC 60884-1, CEE7
- skrutkové upevnenie vodičov 1,5 – 2,5 mm²
- KS zabudovaná detská ochrana pred dotykom kontaktov

SOCKET SCHUKO DOUBLE 2P+E 16A 250V~

- 2P+E schuko double
- 16A 250V~, type VE16
- in accordance with IEC 60884-1, CEE7
- screw contacts 1.5-2.5 mm²
- KS built-in child protection - shuttered live contacts



ZÁSUVKA FRANCÚZSKA DVOJITÁ 2P+E 16A 250 V ~



- VE46PW
- VE46IW
- VE46ES
- VE46NB

- 2P+E francúzska dvojité
- 16 A 250 V ~, typ VE46
- vyhovuje IEC 60884-1, CEE7; NF C 61-314, ČSN 33 2318; PN-E 93201
- skrutkové upevnenie vodičov 1,5 – 2,5 mm²
- KS zabudovaná detská ochrana pred dotykom kontaktov

SOCKET FRENCH DOUBLE 2P+E 16A 250V~

- 2P+E French double
- 16A 250V~, type VE46
- in accordance with IEC 60884-1, CEE7;
- NF C 61-314, ČSN 33 2318; PN-E 93201
- screw contacts 1,5-2,5 mm²
- KS built-in child protection - shuttered live contacts



ZÁSUVKA 2P 16A 250V~



- VE30PW
- VE30IW
- VE30ES
- VE30NB

- 2P bez uzemňovacieho kontaktu
- 16 A 250V~
- vyhovuje EN 60884-1, CEE7 (list I)
- skrutkové upevnenie vodičov 1,5-2,5 mm²

SOCKET 2P 16A 250V~

- 2P without earthing contact
- 16A 250V~
- in accordance with EN 60884-1, CEE7 (standard sheet I)
- screw contacts 1.5-2.5mm²

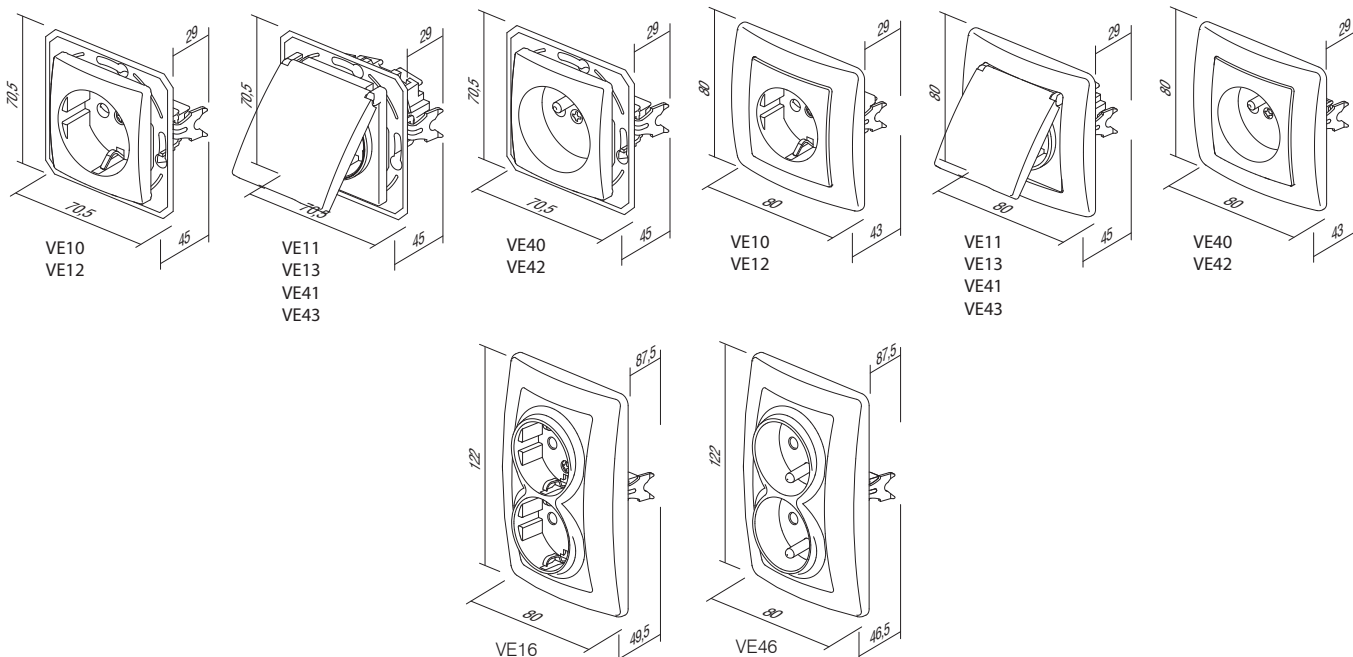



KE37

PW

Typ type	názov description	technické údaje technical data	farba colour
KE11	ZÁSUVKA TV-R KONCOVÁ SOCKET TV-R END-LINE	2dB	<input type="checkbox"/> PW biely-lesklý polar white
KE12	ZÁSUVKA TV-R PRIECHODNÁ SOCKET TV-R THROUGHPASS	8,5dB	<input type="checkbox"/> IW slonová kost-lesklý ivory white
KE16	ZÁSUVKA SAT-TV-R KONCOVÁ SOCKET SAT-TV-R END-LINE	3dB	<input type="checkbox"/> ES strieborný-matný elox silver
.	.	.	<input type="checkbox"/> CO biely duroplast white thermoset
.	.	.	<input type="checkbox"/> NB čierny-lesklý night black

ZÁSUVKA TV-R KONCOVÁ 2dB



KE11



- TV-R koncová
- frekvenčné pásmo 5÷862MHz
- útlm: R-7.5dB, TV-2dB
- vyhovuje EN 50083-1
- skrutkové pripojenie

SOCKET TV-R END-LINE 2dB

- TV-R end-line
- frequency range 5÷862MHz
- reduction: R-7.5dB, TV-2dB
- in accordance with EN 50083-1
- screw contacts

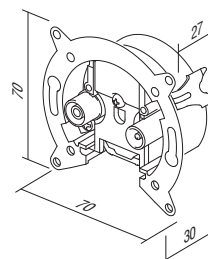

ZÁSUVKA TV-R PRIECHODNÁ 8,5dB



KE12

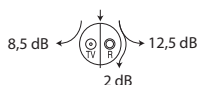

- TV-R priechodná zásuvka
- frekvenčné pásmo 5÷862MHz
- útlm: R-12.5dB, TV-8.5dB, prechod-2dB
- vyhovuje EN 50083-1
- skrutkové pripojenie

SOCKET TV-R THROUGHPASS 8,5dB

- TV-R throughpass
- frequency range 5÷862MHz
- reduction: R-12.5dB, TV-8.5dB, through-2dB
- in accordance with EN 50083-1
- screw contacts

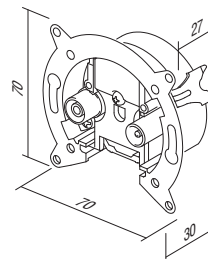

ZÁSUVKA SAT-TV-R KONCOVÁ 3dB



KE16

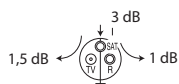

- SAT-TV-R koncová
- frekvenčné pásmo 5÷2400MHz
- útlm: R-1dB, TV-1.5dB, SAT-3dB
- montáž do krabice Ø60 svorkami alebo skrutkami
- vyhovuje EN 50083-1
- skrutkové upevnenie vodičov

SOCKET SAT-TV-R END-LINE 3dB

- SAT-TV-R end-line
- frequency range 5÷2400MHz
- reduction: R-1dB, TV-1.5dB, SAT-3dB
- for mounting in round box Ø60 with claws or screws
- in accordance with EN 50083-1
- screw contacts

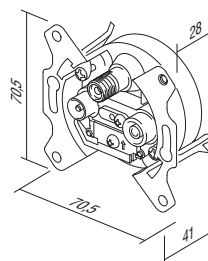

ZÁSUVKA TEL KS RJ11 6/4



KE36

- KS keystone štandard pripojenia
- RJ11 6/4
- vyhovuje IEC 60603-7

SOCKET TEL KS RJ11 6/4

- KS keystone fixing standard
- RJ11 6/4
- in accordance with IEC 60603-7

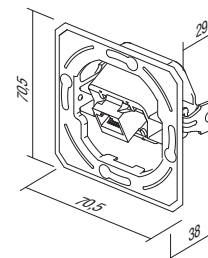

	KE37	<p>ZÁSUVKA CAT5e KS RJ45 8/8</p> <ul style="list-style-type: none"> - KS keystone štandard pripojenia - CAT5e, RJ45 8/8 - vyhovuje IEC 60603-7 <p>SOCKET CAT5e KS RJ45 8/8</p> <ul style="list-style-type: none"> - KS keystone fixing standard - CAT5e, RJ45 8/8 - in accordance with IEC 60603-7 	
	KE38	<p>ZÁSUVKA TEL KS DVOJITÁ 2x RJ11 6/4</p> <ul style="list-style-type: none"> - KS keystone štandard pripojenia - 2x RJ11 6/4 - vyhovuje IEC 60603-7 <p>SOCKET TEL KS DOUBLE 2x RJ11 6/4</p> <ul style="list-style-type: none"> - KS keystone fixing standard - 2x RJ11 6/4 - in accordance with IEC 60603-7 	
	KE39	<p>ZÁSUVKA CAT5e KS DVOJITÁ 2x RJ45 8/8</p> <ul style="list-style-type: none"> - KS keystone štandard pripojenia - 2x CAT5e, RJ45 8/8 - vyhovuje IEC 60603-7 <p>SOCKET CAT5e KS DOUBLE 2x RJ45 8/8</p> <ul style="list-style-type: none"> - KS keystone fixing standard - 2x CAT5e, RJ45 8/8 - in accordance with IEC 60603-7 	
	KE45	<p>ADAPTÉR KS SAMOSTATNÝ</p> <ul style="list-style-type: none"> - KS keystone štandard pripojenia - samostatný - AMP, Avaya, Brandrex, FMT, Mfico, Tyco, ... - neobsahuje komunikačný modul <p>ADAPTER KS SINGLE</p> <ul style="list-style-type: none"> - KS keystone fixing standard - single - AMP, Avaya, Brandrex, FMT, Mfico, Tyco, ... - communication module not included 	
	KE46	<p>ADAPTÉR KS DVOJITÝ</p> <ul style="list-style-type: none"> - KS keystone štandard pripojenia - dvojité - AMP, Tyco, ... - neobsahuje komunikačný modul <p>ADAPTER KS DOUBLE</p> <ul style="list-style-type: none"> - KS keystone fixing standard - double - AMP, Tyco, ... - communication module not included 	
	KE47	<p>ADAPTÉR PD DVOJITÝ</p> <ul style="list-style-type: none"> - PD Panduit MiniCOM štandard pripojenia - dvojité - neobsahuje komunikačný modul <p>ADAPTER PD DOUBLE</p> <ul style="list-style-type: none"> - PD Panduit Mini-COM fixing standard - double - communication module not included 	

ZÁSUVKA TV ZÁKLADNÁ 0dB



- KE10PW
- KE10IW
- KE10ES
- KE10CO
- KE10NB

- TV základná
 - útlm 0dB
 - konektor vzadu – F štandard
- SOCKET TV BASIC 0dB*
- TV basic
 - reduction 0dB
 - back connector – F standard



ZÁSUVKA TV-R KONCOVÁ 2dB



- KE11PW
- KE11IW
- KE11ES
- KE11CO
- KE11NB

- TV-R koncová
 - frekvenčné pásmo 5÷862 MHz
 - útlm: R-7.5dB, TV-2dB
 - vyhovuje EN 50083-1
 - skrutkové pripojenie
- SOCKET TV-R END-LINE 2dB*
- TV-R end-line
 - frequency range 5÷862 MHz
 - reduction: R-7.5dB, TV-2dB
 - in accordance with EN 50083-1
 - screw contact



ZÁSUVKA TV-R PRIEBEŽNÁ 8,5dB



- KE12PW
- KE12IW
- KE12ES
- KE12CO
- KE12NB

- TV-R prechodná
 - frekvenčné pásmo 5÷862 MHz
 - útlm: R-12.5dB, TV-8.5dB, prechod-2dB
 - vyhovuje EN 50083-1
 - skrutkové pripojenie
- SOCKET TV-R THROUGHPASS 8,5dB*
- TV-R throughpass
 - frequency range 5÷862 MHz
 - reduction: R-12.5dB, TV-8.5dB, through-2dB
 - in accordance with EN 50083-1
 - screw contacts



ZÁSUVKA SAT-TV-R KONCOVÁ 3dB



- KE16PW
- KE16IW
- KE16ES
- KE16CO
- KE16NB

- SAT-TV-R koncová
 - frekvenčné pásmo 5÷2400 MHz
 - útlm: R-1dB, TV-1.5dB, SAT-3dB
 - vyhovuje EN 50083-1
 - skrutkové pripojenie
- SOCKET SAT-TV-R END-LINE 3dB*
- SAT-TV-R end-line
 - frequency range 5÷2400 MHz
 - reduction: R-1dB, TV-1.5dB, SAT-3dB
 - in accordance with EN 50083-1
 - screw contacts



ZÁSUVKA AUDIO 2xRCA



- KE22PW
- KE22IW
- KE22ES
- KE22CO
- KE22NB

- audio 2xRCA
 - upevnenie vodičov spájkovaním
- SOCKET AUDIO 2xRCA*
- audio 2xRCA
 - soldering connection of cable



ZÁSUVKA AUDIO REPRODUKTOROVÁ



- KE23PW
- KE23IW
- KE23ES
- KE23CO
- KE23NB

- audio 2x Ø4mm
 - na pripojenie reproduktorového vodiča, banánovej zástrčky Ø4mm alebo vidlicovej pätky
 - upevnenie vodičov vzadu spájkovaním
- SOCKET AUDIO LOUDSPEAKERS*
- audio 2x Ø4mm
 - to accommodate speaker wire, banana plug Ø4mm or spades
 - soldering connection of cable at the back side



ZÁSUVKA TEL KS RJ11 6/4



- KE36PW
- KE36IW
- KE36ES
- KE36CO
- KE36NB

- KS keystone štandard pripojenia
 - RJ11 6/4
 - vyhovuje IEC 60603-7
SOCKET TEL KS RJ11 6/4
 - KS keystone fixing standard
 - RJ11 6/4
 - in accordance with IEC 60603-7



ZÁSUVKA CAT5e KS RJ45 8/8



- KE37PW
- KE37IW
- KE37ES
- KE37CO
- KE37NB

- KS keystone štandard pripojenia
 - CAT5e, RJ45 8/8
 - vyhovuje IEC 60603-7
SOCKET CAT5e KS RJ45 8/8
 - KS keystone fixing standard
 - CAT5e, RJ45 8/8
 - in accordance with IEC 60603-7



ZÁSUVKA TEL KS DVOJITÁ 2x RJ11 6/4



- KE38PW
- KE38IW
- KE38ES
- KE38CO
- KE38NB

- KS keystone štandard pripojenia
 - 2x RJ11, 6/4
 - vyhovuje IEC 60603-7
SOCKET TEL KS DOUBLE 2x RJ11 6/4
 - KS keystone fixing standard
 - 2x RJ11, 6/4
 - in accordance with IEC 60603-7



ZÁSUVKA CAT5e KS DVOJITÁ 2x RJ45 8/8



- KE39PW
- KE39IW
- KE39ES
- KE39CO
- KE39NB

- KS keystone štandard pripojenia
 - 2x CAT5e, RJ45 8/8
 - vyhovuje IEC 60603-7
SOCKET CAT5e KS DOUBLE 2x RJ45 8/8
 - KS keystone fixing standard
 - 2x CAT5e, RJ45 8/8
 - in accordance with IEC 60603-7



ZÁSUVKA TEL LT RJ116/4



- KE35PW
- KE35IW
- KE35ES
- KE35CO
- KE35NB

- TEL LT skrutka
 - skrutkové upevnenie vodičov
 - RJ11 6/4
 - vyhovuje IEC 60603-7
SOCKET TEL LT RJ116/4
 - TEL LT screw
 - screw contacts
 - RJ11 6/4
 - in accordance with IEC 60603-7

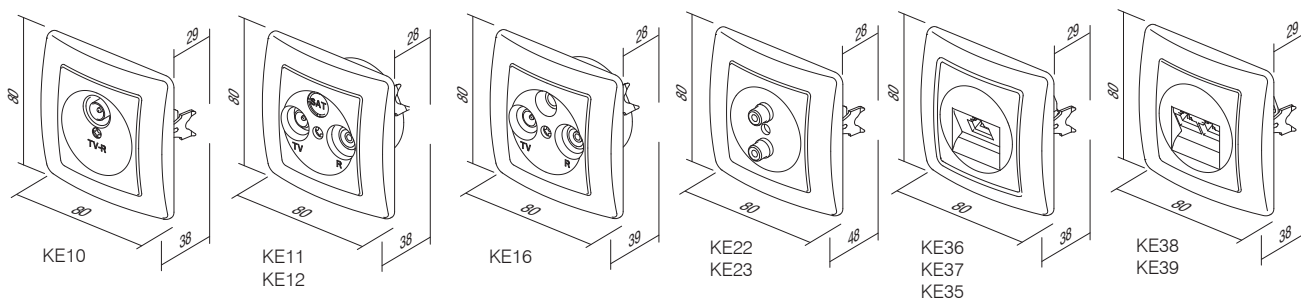

K R Y T Y K O M U N I K Á C I E K E

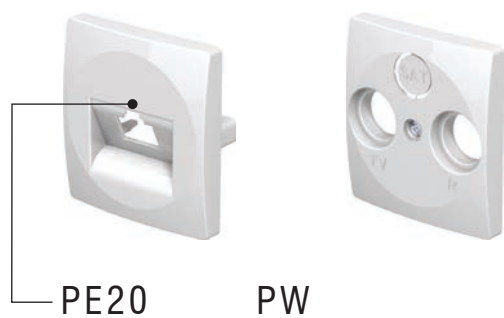

Typ type	názov description	technické údaje technical data	farba colour
PE10	KRYT TV-R COVER TV-R	2P/3P	<input type="checkbox"/> PW biely-lesklý polar white
PE20	KRYT KS SAMOSTATNÝ COVER KS SINGLE		<input type="checkbox"/> IW slonová kosť-lesklý ivory white
PE21	KRYT KS DVOJITÝ COVER KS DOUBLE		<input type="checkbox"/> ES strieborný-matný elox silver
.	.	.	<input type="checkbox"/> CO biely duroplast white thermoset
.	.	.	<input type="checkbox"/> NB čierny-lesklý night black

KRYT TV-R 2P/3P



- PE10PW
- PE10IW
- PE10ES
- PE10CO
- PE10NB

- TV-R kryt, 2P alebo 3P so skrutkou
COVER TV-R 2P/3P
- TV-R cover, 2P or 3P with screw



KRYT KS SAMOSTATNÝ



- PE20PW
- PE20IW
- PE20ES
- PE20CO
- PE20NB

- KS kryt samostatný
COVER KS SINGLE
- KS cover single



KRYT KS DVOJITÝ



- PE21PW
- PE21IW
- PE21ES
- PE21CO
- PE21NB

- KS kryt dvojité
COVER KS DOUBLE
- KS cover double



KRYT TAE/TDO



- PE30PW
- PE30IW
- PE30ES
- PE30CO
- PE30NB

- TAE alebo TDO kryt so skrutkou
COVER TAE/TDO
- TAE or TDO cover with screw

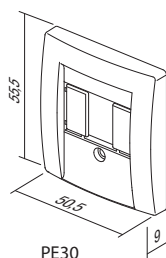

PE30

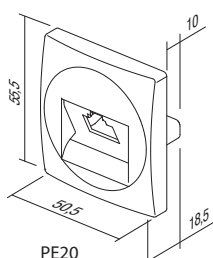

PE20

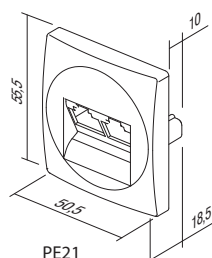

PE21

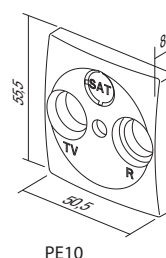

PE10



EE15

PW

Typ type	názov description	technické údaje technical data	farba colour
EE15	STMIEVAČ ROTAČNÝ STR DIMMER ROTATIVE 2WAY	RL 400W	<input type="checkbox"/> PW biely-lesklý polar white
EE16	STMIEVAČ ROTAČNÝ STR DIMMER ROTATIVE 2WAY	RLC 400W	<input type="checkbox"/> IW slonová kost-lesklý ivory white
EE17	STMIEVAČ ROTAČNÝ DIMMER ROTATIVE	FAN 600VA	<input type="checkbox"/> ES strieborný-matný elox silver
.	.	.	<input type="checkbox"/> CO biely duroplast white thermoset
.	.	.	<input type="checkbox"/> NB čierny-lesklý night black

STMIEVAČ ROTAČNÝ STR RL 400W



EE15

- rotačný so striedavým spínačom
- záťaž RL, 40W - 400W
- možné prepojenie so striedavým spínačom
- prepojenie viacerých stmievačov nie je dovolené
- vyhovuje EN 60669-1 a EN 60669-2-1
- bezskrútkové upevnenie vodičov 1,5mm²
- napájanie 230V~ 50Hz
- priemer nástavca gombíka Ø6mm
- obsahuje vymeniteľný istič

DIMMER ROTATIVE 2WAY RL 400W

- rotation control with 2-way switch
- load RL, 40W - 400W
- 2-way switch combination is possible
- more dimmers combination is not allowed
- in accordance with EN 60669-1 and EN 60669-2-1
- plug-in contacts 1.5mm²
- supply 230V~ 50Hz
- button inner diameter Ø6mm
- replaceable fuse included

STMIEVAČ ROTAČNÝ STR RLC 400W



EE16

- rotačný so striedavým spínačom
- záťaž RLC, 20W - 400W
- možné prepojenie so striedavým spínačom
- prepojenie viacerých stmievačov nie je dovolené
- vyhovuje EN 60669-1 a EN 60669-2-1
- bezskrútkové upevnenie vodičov 1,5 mm²
- napájanie 230V~ 50Hz
- priemer nástavca gombíka Ø6mm
- elektronický istič

DIMMER ROTATIVE 2WAY RLC 400W

- rotation control with 2-way switch
- load RLC, 20W - 400W
- 2-way switch combination is possible
- more dimmers combination is not allowed
- in accordance with EN 60669-1 and EN 60669-2-1
- plug-in contacts 1.5mm²
- button inner diameter Ø6mm
- supply 230V~ 50Hz
- electronic fuse



EE17

STMIEVAČ ROTAČNÝ VENTILÁTOR 600VA

- rotačný so spínačom
- typ 456, záťaž: motor, 25VA - 600VA
- prepojenie so striedavým spínačom nie je možné
- prepojenie viacerých stmievačov nie je dovolené
- vyhovuje EN 60669-1 a EN 60669-2-1
- bezskrutkové upevnenie vodičov 1,5 mm²
- napájanie 230V~ 50Hz
- priemer nástavca gombíka Ø4mm
- obsahuje vymeniteľný istič

DIMMER ROTATIVE FAN 600VA

- rotation control with switch
- type 456; load: motor, 25VA - 600VA
- 2-way switch combination is not possible
- more dimmers combination is not allowed
- in accordance with EN 60669-1 and EN 60669-2-1
- plug-in contacts 1.5mm²
- supply 230V~ 50Hz
- button inner diameter Ø4mm
- replaceable fuse included



- EE15PW
- EE15IW
- EE15ES
- EE15CO
- EE15NB

STMIEVAČ ROTAČNÝ STR RL 400W

- rotačný so striedavým spínačom
- záťaž RL, 40W - 400W
- možné prepojenie so striedavým spínačom
- prepojenie viacerých stmievačov nie je dovolené
- vyhovuje EN 60669-1 a EN 60669-2-1
- bezskrutkové upevnenie vodičov 1,5 mm²
- napájanie 230V~ 50Hz
- obsahuje vymeniteľný istič

DIMMER ROTATIVE 2WAY RL 400W

- rotation control with 2-way switch
- load RL, 40W - 400W
- 2-way switch combination is possible
- more dimmers combination is not allowed
- in accordance with EN 60669-1 and EN 60669-2-1
- plug-in contacts 1.5mm²
- supply 230V~ 50Hz
- replaceable fuse included



- EE16PW
- EE16IW
- EE16ES
- EE16CO
- EE16NB

STMIEVAČ ROTAČNÝ STR RLC 400W

- rotačný so striedavým spínačom
- záťaž RLC, 20W - 400W
- možné prepojenie so striedavým spínačom
- prepojenie viacerých stmievačov nie je dovolené
- vyhovuje EN 60669-1 a EN 60669-2-1
- bezskrutkové upevnenie vodičov 1,5 mm²
- napájanie 230V~ 50Hz
- elektronický istič

DIMMER ROTATIVE 2WAY RLC 400W

- rotation control with 2-way switch
- load RLC, 20W - 400W
- 2-way switch combination is possible
- more dimmers combination is not allowed
- in accordance with EN 60669-1 and EN 60669-2-1
- plug-in contacts 1.5mm²
- supply 230V~ 50Hz
- electronic fuse



EE15, EE16

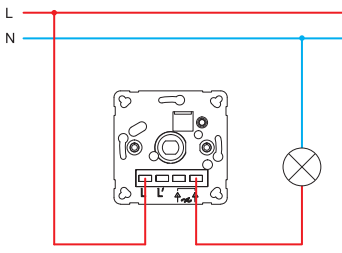

EE15, EE16

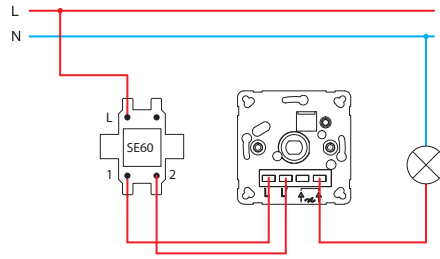

EE15, EE16

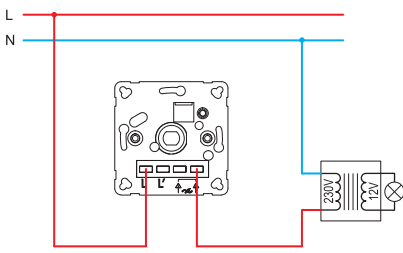

EE15, EE16

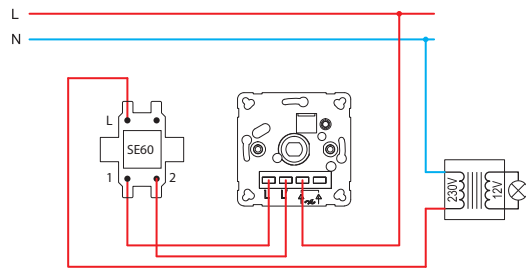

EE16

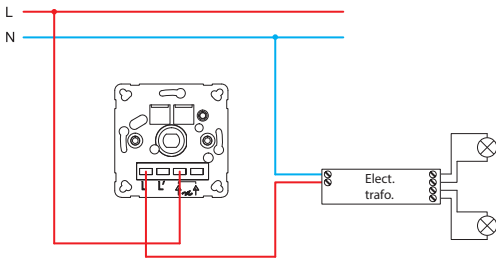

EE16

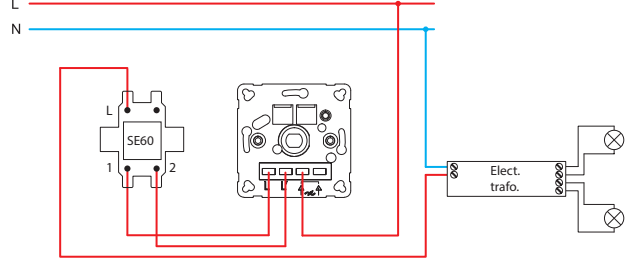

EE17

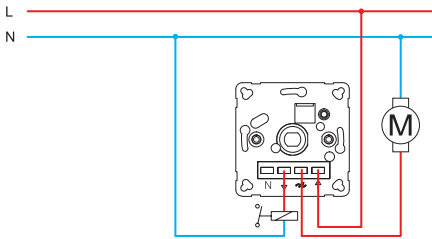

EE15 (40÷400W)

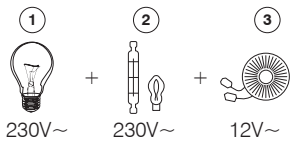

EE16 (20÷400W)

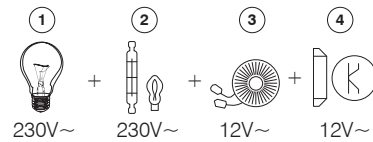

- 1 - žiarovka so žiariacim vláknom / incandescent lamp
- 2 - halogénová žiarovka / halogen lamp
- 3 - klasický transformátor / classical transformer
- 4 - elektronický transformátor / electronic transformer

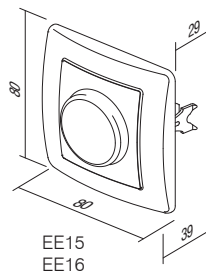
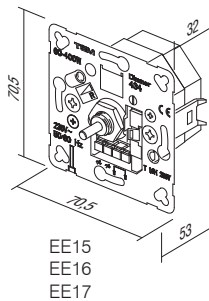

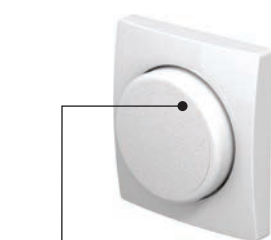

PE40

PW

Typ type	názov description	farba colour
PE40	KRYT STMIEVACÍ SPÍNAČ COVER DIMMER	<input type="checkbox"/> PW biely-lesklý polar white <input type="checkbox"/> IW slonová kost-lesklý ivory white <input type="checkbox"/> ES strieborný-matný elox silver <input type="checkbox"/> CO biely duroplast white thermoset <input type="checkbox"/> NB čierny-lesklý night black

KRYT STMIEVACÍ SPÍNAČ Ø4



- PE40PW
- PE40IW
- PE40ES
- PE40CO
- PE40NB

- kryt stmievací spínač Ø4mm
- pre EE17

COVER DIMMER Ø4
- cover dimmer Ø4mm
- for EE17



KRYT STMIEVACÍ SPÍNAČ Ø6



- PE41PW
- PE41IW
- PE41ES
- PE41CO
- PE41NB

- kryt stmievací spínač Ø6mm
- pre EE15, 16, 18

COVER DIMMER Ø6
- cover dimmer Ø6mm
- for EE15, 16, 18

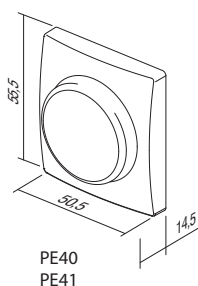

PE40
PE41



AE10

PW

Typ type	názov description	farba colour
AE10	VÝPLŇ BLANK	<input type="checkbox"/> PW biely-lesklý polar white
AE20	PRÍPOJKA PÄŤPÓLOVÁ FIXNÁ 3P+N+E 5X4mm ² CONNECTION BOX 3P+N+E 5X4mm ²	<input type="checkbox"/> IW slonová kosť-lesklý ivory white
AE30	KRYT NO 1 SURFACE MOUNT BOX	<input type="checkbox"/> ES strieborný-matný elox silver
.		<input type="checkbox"/> CO biely duroplast white thermoset
.		<input checked="" type="checkbox"/> NB čierny-lesklý night black

VÝPLŇ



- AE10PW
- AE10IW
- AE10ES
- AE10CO
- AE10NB

- na vyplnenie prázdnych otvorov

BLANK
- for filling up empty spaces

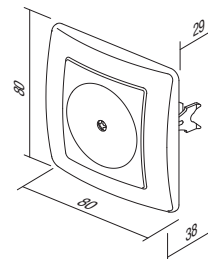

PRÍPOJKA PÄŤPÓLOVÁ FIXNÁ 3P+N+E 5x4mm²



- AE20PW
- AE20IW

- 3P+N+E fixná prípojka
- 16A 400V~
- vyhovuje VDE 0606-1:2000
- skrutkové upevnenie vodičov 1,5-4 mm²

CONNECTION BOX SPOLE 3P+N+E 5x4mm²
- 3P+N+E connection box
- 16A 400V~
- in accordance with VDE 0606-1:2000
- screw contacts 1.5-4mm²

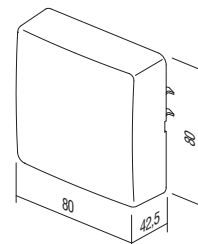

RÁM NO 1

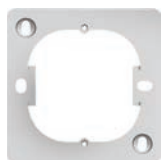

- AE30PW
- AE30IW

- povrchový rám
SURFACE MOUNT BOX 1
- surface mounting box

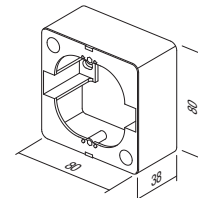



- AE50PW
- AE50TS

STENOVÝ CHRÁNIČ

- chránič steny okolo spínača alebo zásuvky
WALL PROTECTION
 - protects surface around socket or switch

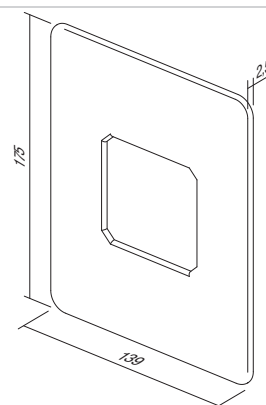

- AE51PW
- AE51IW

DETSKÁ OCHRANA KS

- KS detská ochrana pred dotykom kontaktov
CHILD PROTECTION KS
 - KS additional child protection insert - shuttered live contacts

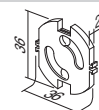



OE10

PW

Typ type	názov description	farba colour
OE10	RÁMIK EKONOMIK 1 SURROUND EKONOMIK 1	<input type="checkbox"/> PW biely-lesklý polar white
OE20	RÁMIK EKONOMIK 2 HORIZONTÁLNY SURROUND EKONOMIK 2 HORIZONTAL	<input type="checkbox"/> IW slonová kosť-lesklý ivory white
OE30	RÁMIK EKONOMIK 3 HORIZONTÁLNY SURROUND EKONOMIK 3 HORIZONTAL	<input type="checkbox"/> ES strieborný-matný elox silver
.		<input type="checkbox"/> CO biely duroplast white thermoset
.		<input checked="" type="checkbox"/> NB čierny-lesklý night black

RÁMIK EKONOMIK 1



- OE10PW
- OE10IW
- OE10ES
- OE10CO
- OE10NB

- dekoratívny samostatný rámik
- vyhovuje EN 60669-1
SURROUND EKONOMIK 1
- decorative surround 1-gang
- in accordance with EN 60669-1

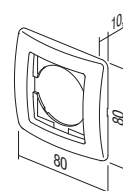

RÁMIK EKONOMIK 2 HORIZONTÁLNY



- OE20PW
- OE20IW
- OE20ES
- OE20CO
- OE20NB

- dekoratívny dvojité horizontálny rámik
- vyhovuje EN 60669-1
SURROUND EKONOMIK 2 HORIZONTAL
- decorative surround 2-gang horizontal
- in accordance with EN 60669-1

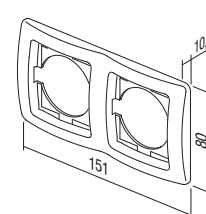

RÁMIK EKONOMIK 2 VERTIKÁLNY



- OE21PW
- OE21IW
- OE21ES
- OE21CO
- OE21NB

- dekoratívny dvojité vertikálny rámik
- vyhovuje EN 60669-1
SURROUND EKONOMIK 2 VERTICAL
- decorative surround 2-gang vertical
- in accordance with EN 60669-1

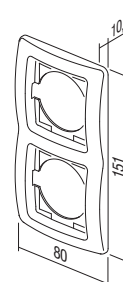

RÁMIK EKONOMIK 3 HORIZONTÁLNY



- OE30PW
- OE30IW
- OE30ES
- OE30CO
- OE30NB

- dekoratívny trojitý horizontálny rámik
- vyhovuje EN 60669-1
SURROUND EKONOMIK 3 HORIZONTAL
- decorative surround 3-gang horizontal
- in accordance with EN 60669-1

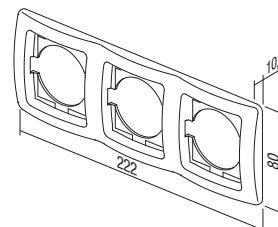



- OE31PW
- OE31IW
- OE31ES
- OE31CO
- OE31NB

RÁMIK EKONOMIK 3 VERTIKÁLNY

- dekoratívny trojitý vertikálny rámik
- vyhovuje EN 60669-1

SURROUND EKONOMIK 3 VERTICAL
- decorative surround 3-gang vertical
- in accordance with EN 60669-1

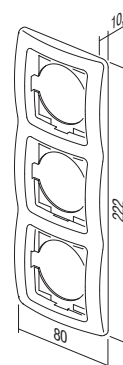

- OE40PW
- OE40IW
- OE40ES
- OE40NB

RÁMIK EKONOMIK 4 HORIZONTÁLNY

- dekoratívny štvoritý horizontálny rámik
- vyhovuje EN 60669-1

SURROUND EKONOMIK 4 HORIZONTAL
- decorative surround 4-gang horizontal
- in accordance with EN 60669-1

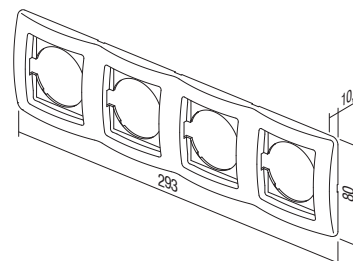

- OE41PW
- OE41IW
- OE41ES
- OE41NB

RÁMIK EKONOMIK 4 VERTIKÁLNY

- dekoratívny štvoritý vertikálny rámik
- vyhovuje EN 60669-1

SURROUND EKONOMIK 4 VERTICAL
- decorative surround 4-gang vertical
- in accordance with EN 60669-1

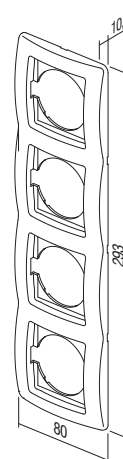

DEKORATÍVNE RÁMIKY COLOUR / COLOUR DECORATIVE FRAMES



- OE90GR ZELENÝ / GREEN
- OE90BL MODRÝ / BLUE
- OE90VO FIALOVÝ / VIOLET
- OE90PI RUŽOVÝ / PINK
- OE90RD ČERVENÝ / RED
- OE90YL ŽLTÝ / YELLOW
- OE90WH BIELY / WHITE
- OE90GY SIVÝ / GREY
- OE90BK ČIERNY / BLACK
- OE90BR HNEDÝ / BROWN

- OE90MB KOVOVO MODRÝ / MET. BLUE
- OE90BZ BRONZOVÝ / BRONZE
- OE90CR STRIEBORNÝ / SILVER
- OE90GO ZLATÝ / GOLD



TEM



KATALOG / CATALOGUE

fontana



SPÍNAČE SF
SWITCHES SF



190

ZÁSUVKY VF
SOCKETS VF



192

SADY CF
SETS CF



193

PRÍSLUŠENSTVO AF
ACCESSORIES AF



195



SF10

PW

TI

typ type	názov description	technické údaje technical data	farba colour	fakultatívny opis 1 optional data 1
SF10	SPÍNAČ JEDNOPÓLOVÝ SWITCH 1WAY	IP44 10AX 250V~	<input type="checkbox"/> PW biela white	TI výbojka + indikátor neon lamp+indication
SF11	KRYTKA NA TLAČIDLO JEDNOPÓLOVÁ PUSH BUTTON 1WAY	IP44 10A 250V~	<input type="checkbox"/> GY sivá - matná grey-mat	
SF20	SPÍNAČ DVOJPÓLOVÝ SWITCH 2POLE	IP44 10AX 250V~		
.

SPÍNAČ JEDNOPÓLOVÝ IP44 10AX 250V~



- SF10PW
- SF10GY

- 10AX 250V~, typ SF10
- vyhovuje EN 60669-1
- bezskrútkové upevnenie vodičov 1,5-2,5 mm²
SWITCH 1WAY IP44 10AX 250V~
- 10AX 250V~, type SF10
- in accordance with EN 60669-1
- plug-in contacts 1.5-2.5mm²

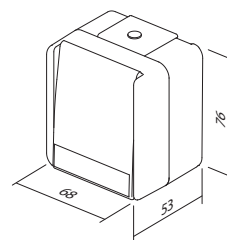

SPÍNAČ JEDNOPÓLOVÝ IP44 10A 250V~ __ TI



- SF10PWTI
- SF10GYTI

- TI indikátor + výbojka
- 10A 250V~, typ SF10
- vyhovuje EN 60669-1
- bezskrútkové upevnenie vodičov 1,5-2,5 mm²
SWITCH 1WAY IP44 10AX 250V~ __ TI
- TI indicator+neon lamp
- 10A 250V~, type SF10
- in accordance with EN 60669-1
- plug-in contacts 1.5-2.5mm²

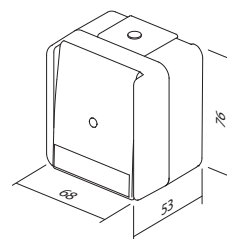

KRYTKA NA TLAČIDLO JEDNOPÓLOVÁ IP44 10A 250V~ __ TI



- SF11PWTI
- SF11GYTI

- TI indikátor + výbojka
- 10A 250V~, typ SF11
- vyhovuje EN 60669-1
- bezskrútkové upevnenie vodičov 1,5-2,5 mm²
PUSH BUTTON 1WAY IP44 10A 250V~ __ TI
- TI indicator+neon lamp
- 10A 250V~, type SF11
- in accordance with EN 60669-1
- plug-in contacts 1.5-2.5mm²

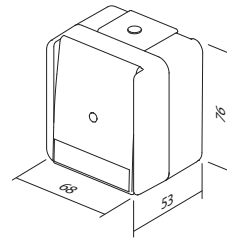

SPÍNAČ DVOJPÓLOVÝ IP44 10AX 250V~



- SF20PW
- SF20GY

- 10AX 250V~, typ SF20
- vyhovuje EN 60669-1
- bezskrútkové upevnenie vodičov 1,5-2,5 mm²
SWITCH 2POLE IP44 10AX 250V~
- 10AX 250V~, type SF20
- in accordance with EN 60669-1
- plug-in contacts 1.5-2.5mm²

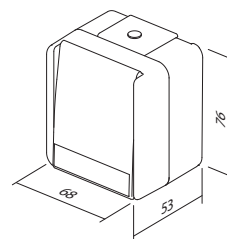

SPÍNÁČ SÉRIOVÝ IP44 10AX 250V~



- SF50PW
- SF50GY

- 10AX 250V~, typ SF50
- vyhovuje EN 60669-1
- bezskrútkové upevnenie vodičov 1,5-2,5 mm²

SWITCH 2GANG-1WAY IP44 10AX 250V~
 - 10AX 250V~, type SF50
 - in accordance with EN 60669-1
 - plug-in contacts 1.5-2.5mm²

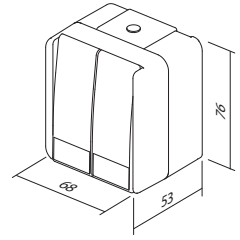

SPÍNÁČ SÉRIOVÝ IP44 10A 250V~



- SF51PW
- SF51GY

- 10A 250V~, typ SF51
- vyhovuje EN 60669-1
- bezskrútkové upevnenie vodičov 1,5-2,5 mm²

PUSH BUTTON 2GANG-1WAY IP44 10A 250V~
 - 10A 250V~, type SF51
 - in accordance with EN 60669-1
 - plug-in contacts 1.5-2.5mm²

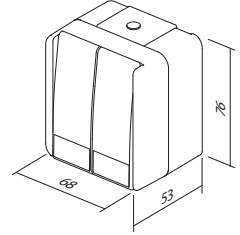

SPÍNÁČ STRIEDAVÝ IP44 10AX 250V~



- SF60PW
- SF60GY

- 10AX 250V~, typ SF60
- vyhovuje EN 60669-1
- bezskrútkové upevnenie vodičov 1,5-2,5 mm²

SWITCH 2WAY IP44 10AX 250V~
 - 10AX 250V~, type SF60
 - in accordance with EN 60669-1
 - plug-in contacts 1.5-2.5mm²

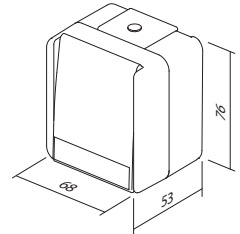

SPÍNÁČ STRIEDAVÝ IP44 10AX 250V~ __ TI



- SF60PWTI
- SF60GYTI

- TI indikátor + výbojka
- 10AX 250V~, typ SF60
- vyhovuje EN 60669-1
- bezskrútkové upevnenie vodičov 1,5-2,5 mm²

SWITCH 2WAY IP44 10AX 250V~ __ TI
 - TI indicator+neon lamp
 - 10AX 250V~, type SF60
 - in accordance with EN 60669-1
 - plug-in contacts 1.5-2.5mm²

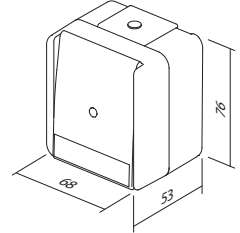

SPÍNÁČ DVOJITÝ STRIEDAVÝ IP44 10AX 250V~



- SF63PW
- SF63GY

- 10AX 250V~, typ SF63
- vyhovuje EN 60669-1
- bezskrútkové upevnenie vodičov 1,5-2,5 mm²

SWITCH 2WAY DOUBLE IP44 10AX 250V~
 - 10AX 250V~, type SF63
 - in accordance with EN 60669-1
 - plug-in contacts 1.5-2.5mm²

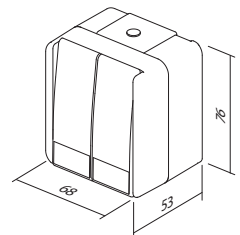

SPÍNÁČ KRÍŽOVÝ IP44 10AX 250V~



- SF70PW
- SF70GY

- 10AX 250V~, typ SF70
- vyhovuje EN 60669-1
- bezskrútkové upevnenie vodičov 1,5-2,5 mm²

SWITCH INTERMEDIATE IP44 10AX 250V~
 - 10AX 250V~, type SF70
 - in accordance with EN 60669-1
 - plug-in contacts 1.5-2.5mm²

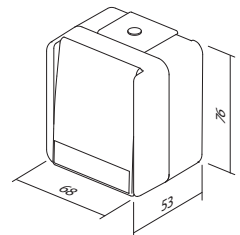



VF10

PW

Typ type	názov description	technické údaje technical data	farba colour
VF10	ZÁSUVKA SCHUKO + KRYT SOCKET SCHUKO+COVER	IP44 2P+E 16A 250V~	<input type="checkbox"/> PW biela - matná white-mat <input type="checkbox"/> GY sivá - matná grey-mat

ZÁSUVKA SCHUKO + KRYT IP44 2P+E 16A 250V~



- VF10PW
- VF10GY

- skrutkové upevnenie vodičov 1,5-2,5 mm²
- 2P+E schuko + kryt
- 16A 250V~, typ VF10
- vyhovuje EN60884-1, CEE7

- SOCKET SCHUKO+COVER IP44 2P+E 16A 250V~
- screw contacts 1.5-2.5mm²
- 2P+E schuko+cover
- 16A 250V~, type VF10
- in accordance with EN 60884-1, CEE7

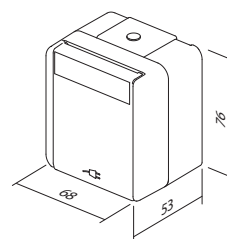

ZÁSUVKA SCHUKO + KRYT IP44 2P+E 16A 250V~ BV



- VF12PW
- VF12GY

- BV bezskrutkové upevnenie vodičov 1,5-2,5 mm²
- 2P+E schuko + kryt
- 16A 250V~, typ VF12
- vyhovuje EN60884-1, CEE7

- SOCKET SCHUKO+COVER IP44 2P+E 16A 250V~ BV
- BV plug-in contacts 1.5-2.5mm²
- 2P+E schuko+cover
- 16A 250V~, type VF12
- in accordance with EN 60884-1, CEE7

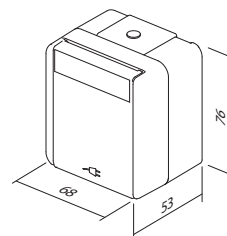

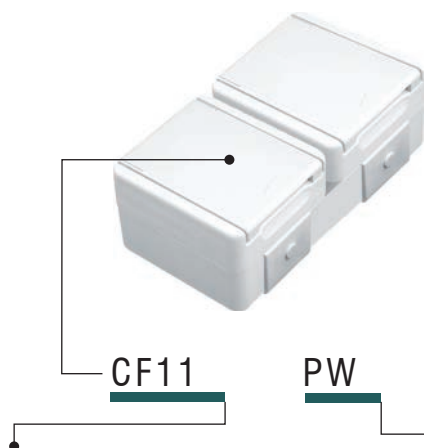

Typ type	názov description	technické údaje technical data	farba colour
CF10	SADA ZÁSUVKA SCHUKO DVOJITÁ HORIZ SOCKET SET SCHUKO DOUBLE HORIZ	2x 2P+E 16A 250V~ IP44	<input type="checkbox"/> PW biela-matná white-mat
CF11	SADA ZÁSUVKA SCHUKO DVOJITÁ VERT SOCKET SET SCHUKO DOUBLE VERT	2x 2P+E 16A 250V~ IP44	<input type="checkbox"/> GY sivá-matná grey-mat
CF12	SADA ZÁSUVKA SCH + SPÍNAČ STR HORIZ SOCKET SCH+SWITCH 2WAY HORIZ	16A + 10A 250V~ IP44	
.	.	.	.

SADA ZÁSUVKA SCHUKO DVOJITÁ HORIZONTÁLNA IP44 2x 2P+E 16A 250V~



- CF10PW
 - CF10GY
- skrutkové upevnenie vodičov 1,5-2,5 mm²
 - 2x 2P+E schuko + kryt horizontálny
 - 16A 250V~, typ CF10
 - vyhovuje EN60884-1, CEE7

SOCKET SET SCHUKO DOUBLE HORIZONTAL
IP44 2x 2P+E 16A 250V~

- screw contacts 1.5-2.5mm²
- 2x 2P+E schuko+cover horizontal
- 16A 250V~, type CF10
- in accordance with EN 60884-1, CEE7

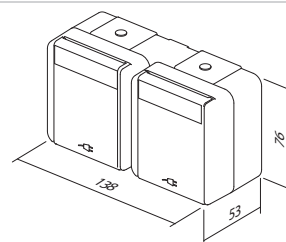

SADA ZÁSUVKA SCHUKO DVOJITÁ VERTIKÁLNA IP44 2x 2P+E 16A 250V~



- CF11PW
 - CF11GY
- skrutkové upevnenie vodičov 1,5-2,5 mm²
 - 2x 2P+E schuko + kryt vertikálny
 - 16A 250V~, typ CF11
 - vyhovuje EN60884-1, CEE7

SOCKET SET SCHUKO DOUBLE VERTICAL
IP44 2x 2P+E 16A 250V~

- screw contacts 1.5-2.5mm²
- 2x 2P+E schuko+cover vertical
- 16A 250V~, type CF11
- in accordance with EN 60884-1, CEE7

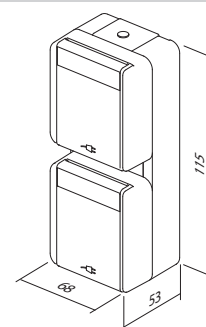

SADA ZÁSUVKA SCH + SPÍNAČ STR HORIZONTÁLNY IP44 16A + 10AX 250V~



- CF12PW
 - CF12GY
- skrutkové (zásuvka), bezskrutkové (spínač) upevnenie vodičov 1,5-2,5mm²
 - 2P+E schuko + kryt + spínač striedavý horizontálny
 - 16A + 10AX 250V~, typ CF12
 - vyhovuje EN 60884-1, CEE7, EN 60669-1

SOCKET SCH+SWITCH SET 2WAY HORIZONTAL
IP44 16A + 10AX 250V~

- screw (socket), plug-in (switch) contacts 1.5-2.5mm²
- 2P+E schuko+cover + switch 2-way horizontal
- 16A + 10AX 250V~, type CF12
- in accordance with EN 60884-1, CEE7, EN 60669-1

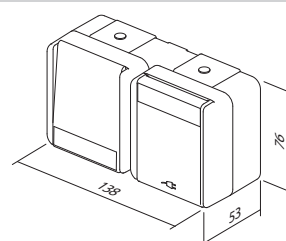

**SADA ZÁSUVKA SCH + SPÍNAČ STR VERTIKÁLNY
IP44 16A + 10AX 250V~**

- CF13PW
- CF13GY

- skrutkové (zásuvka), bezskrutkové (spínač) upevnenie vodičov 1,5-2,5 mm²
- 2P+E schuko + kryt + spínač striedavý vertikálny
- 16A + 10AX 250V~, typ CF13
- vyhovuje EN 60884-1, CEE7, EN 60669-1

**SOCKET SCH+SWITCH 2WAY SET VERTICAL
IP44 16A + 10AX 250V~**

- screw (socket), plug-in (switch)
- contacts 1.5-2.5mm²
- 2P+E schuko+cover + switch 2-way vertical
- 16A + 10AX 250V~, type CF13
- in accordance with EN 60884-1, CEE7, EN 60669-1

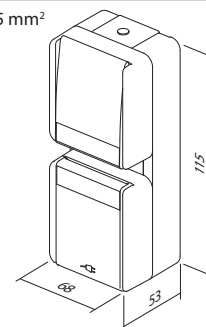

**SADA ZÁSUVKA SCHUKO DVOJITÁ HORIZONTÁLNA
IP44 2x 2P+E 16A 250V~ BV**

- CF14PW
- CF14GY

- BV bezskrutkové upevnenie vodičov 1,5-2,5 mm²
- 2x 2P+E schuko + kryt horizontálna
- 16A 250V~, typ CF14
- vyhovuje EN60884-1, CEE7

SOCKET SET SCHUKO DOUBLE HORIZONTAL

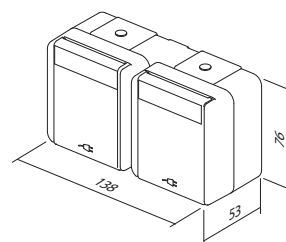
- IP44 2x 2P+E 16A 250V~ BV
- BV plug-in contacts 1.5-2.5mm²
- 2x 2P+E schuko+cover horizontal
- 16A 250V~, type CF14
- in accordance with EN 60884-1, CEE7



**SADA ZÁSUVKA SCHUKO DVOJITÁ VERTIKÁLNA
IP44 2x 2P+E 16A 250V~BV**

- CF15PW
- CF15GY

- BV bezskrutkové upevnenie vodičov 1,5-2,5 mm²
- 2x 2P+E schuko + kryt vertikálna
- 16A 250V~, typ CF15
- vyhovuje EN60884-1, CEE7

SOCKET SET SCHUKO DOUBLE VERTICAL

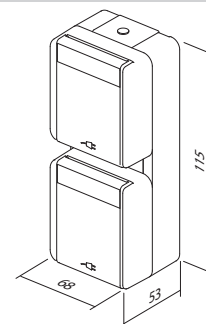
- IP44 2x 2P+E 16A 250V~ BV
- BV plug-in contacts 1.5-2.5mm²
- 2x 2P+E schuko+cover vertical
- 16A 250V~, type CF15
- in accordance with EN 60884-1, CEE7



**SADA ZÁSUVKA SCH + SPÍNAČ STR HORIZONTÁLNY
IP44 16A + 10AX 250V~BV**

- CF16PW
- CF16GY

- BV bezskrutkové upevnenie vodičov 1,5-2,5 mm²
- 2P+E schuko + kryt + spínač striedavý horizontálny
- 16A + 10AX 250V~, typ CF16
- vyhovuje EN 60884-1, CEE7, EN 60669-1

SOCKET+SWITCH SET SCH+2WAY HORIZONTAL

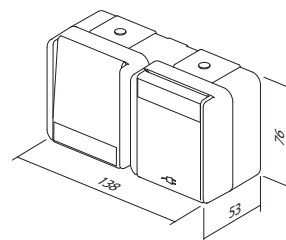
- IP44 16A + 10AX 250V~ BV
- BV plug-in contacts 1.5-2.5mm²
- 2P+E schuko+cover + switch 2-way horizontal
- 16A + 10AX 250V~, type CF16
- in accordance with EN 60884-1, CEE7, EN 60669-1



**SADA ZÁSUVKA SCH + SPÍNAČ STR VERTIKÁLNY
IP44 16A + 10AX 250V~BV**

- CF17PW
- CF17GY

- BV bezskrutkové upevnenie vodičov 1,5-2,5 mm²
- 2P+E schuko + kryt + spínač striedavý vertikálny
- 16A + 10AX 250V~, typ CF17
- vyhovuje EN 60884-1, CEE7, EN 60669-1

SOCKET SCH+SWITCH 2WAY SET VERTICAL

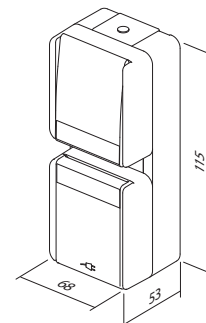
- IP44 16A + 10AX 250V~ BV
- BV plug-in contacts 1.5-2.5mm²
- 2P+E schuko+cover + switch 2-way vertical
- 16A + 10AX 250V~, type CF17
- in accordance with EN 60884-1, CEE7, EN 60669-1





AF10



PW

Typ type	názov description	technické údaje technical data	farba colour
AF10	ROZVODNÁ KRABICA DISTRIBUTION BOX	IP44 RN01	<input type="checkbox"/> PW biely-matný white-mat
AF20	ROZVODNÁ KRABICA DISTRIBUTION BOX	IP55 NDO1	<input type="checkbox"/> GY sivý-matný grey-mat

ROZVODNÁ KRABICA IP44 RN01



- AF10PW
 AF10GY

- povrchový rozvodná krabica IP44
- 16A 400V~
- vyhovuje EN 60309-1

DISTRIBUTION BOX IP44 RN01

- surface mounting distribution box IP44
- 16A 400V~
- in accordance with EN 60309-1

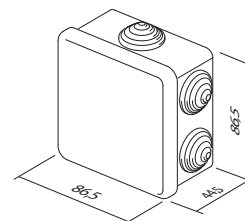

ROZVODNÁ KRABICA IP55 ND01



- AF20PW
 AF20GY

- povrchový rozvodná krabica IP55
- priečodky priložené
- vyhovuje EN 60309-1

DISTRIBUTION BOX IP55 ND01

- surface mounting connection box IP55
- glands included
- in accordance with EN 60309-1

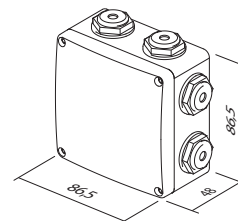

MODUL

kód	popis výrobku	strana
SPÍNAČE SM		
SM10	SPÍNAČ JEDNOPÓLOVÝ 16AX 250V~ 1M	54
SM11	SPÍNAČ JEDNOPÓLOVÝ 16A 250V~ 1M	54
SM12	SPÍNAČ JEDNOPÓLOVÝ 20A 250V~ 1M	54
SM20	SPÍNAČ DVOJPÓLOVÝ 16AX 250V~ 1M	54
SM40	ŽALÚZIOVÝ SPÍNAČ 1-0-2 16AX 250V~ 1M	55
SM41	ŽALÚZIOVÝ SPÍNAČ 1-0-2 16A 250V~ 1M	55
SM60	SPÍNAČ STRIEDAVÝ 16AX 250V~ 1M	55
SM61	SPÍNAČ STRIEDAVÝ 16A 250V~ 1M	55
SM70	SPÍNAČ KRÍŽOVÝ 16AX 250V~ 1M	55
SM10--	SPÍNAČ JEDNOPÓLOVÝ 16AX 250V~ 1M	56
SM10--IN	SPÍNAČ JEDNOPÓLOVÝ 16AX 250V~ 1M IN	56
SM11--	SPÍNAČ JEDNOPÓLOVÝ 16A 250V~ 1M	56
SM11--IN01	SPÍNAČ JEDNOPÓLOVÝ 16A 250V~ 1M IN 01	56
SM11--IN02	SPÍNAČ JEDNOPÓLOVÝ 16A 250V~ 1M IN 02	57
SM20--NT03	SPÍNAČ DVOJPÓLOVÝ 16AX 250V~ 1M NT 03	57
SM20--IN	SPÍNAČ DVOJPÓLOVÝ 16AX 250V~ 1M IN	57
SM40--NT10	SPÍNAČ ŽALÚZIOVÝ 1-0-2 16AX 250V~ 1M NT 10	57
SM41--NT10	SPÍNAČ ŽALÚZIOVÝ 1-0-2 16A 250V~ 1M NT 10	57
SM60--	SPÍNAČ STRIEDAVÝ 16AX 250V~ 1M	57
SM61--	SPÍNAČ STRIEDAVÝ 16A 250V~ 1M	58
SM62--CD	SPÍNAČ STRIEDAVÝ SO ŠNURKOU 16A 250V~ 1M CD	58
SM70 --	SPÍNAČ KRÍŽOVÝ 16AX 250V~ 1M	58
KRYTKY NA SPÍNAČE TM		
TM11--	KRYTKA NA SPÍNAČ 1M	59
TM11-- IN	KRYTKA NA SPÍNAČ 1M IN	59
TM12--	KRYTKA NA SPÍNAČ 2M	59
TM12--IN	KRYTKA NA SPÍNAČ 2M IN	59
TM13--IL	KRYTKA NA SPÍNAČ S NÁPISOVÝM ŠTÍTKOM 2M	60
TM15--	KRYTKA NA SPÍNAČ 1M DVOJPÓLOVÁ	60
TM21--	VÝPLŇ 1M	60
TM22--	VÝPLŇ 2M	60
TM31--	PRIECHODKA 1M	60
INDIKÁCIA IA		
IA10--	VÝBOJKA 230V~ 0,34W	62
IA20--	ŽIARIVKA LED 230V AC/DC 0,40W	62
IA21--	ŽIARIVKA LED 24V AC/DC 0,20W	62
IA22--	ŽIARIVKA LED 12V AC/DC 0,10W	62
ZÁSUVKY VM		
VM10--	ZÁSUVKA SCHUKO+KS 2P+E 16A 250V~ 2M	64
VM11--	ZÁSUVKA SCHUKO+KS+KRYT 2P+E 16A 250V~ 2M	64
VM20--	ZÁSUVKA EURO+KS 2P 10A 250V~ 1M	65
VM40--	ZÁSUVKA FRANCÚZSKA+KS 2P+E 16A 250V~ 2M	65
VM41--	ZÁSUVKA FRANCÚZSKA+KS+KRYT 2P+E 16A 250V~ 2M	65
VM30--	ZÁSUVKA TALIANSKA P17/11+KS 2P+E 16A 250V~ 1M	65
VM31--	ZÁSUVKA SCHUKO/ITA P17/11+KS 2P+E 16A 250V~ 2M	65
VM32--	ZÁSUVKA SCHUKO/ITA P30+KS 2P+E 16A 250V~ 2M	66
VM33--	ZÁSUVKA TALIANSKA P11+KS 2P+E 10A 250V ~ 1M	66
VM21--	ZÁSUVKA EURO/AMERICKÁ +KS 2P 16A 250V~ 1M	66
VM51--	ZÁSUVKA BRITSKÁ BS546+KS 2P+E 15A 250V~ 2M	66
VM52--	ZÁSUVKA BRITSKÁ BS 1363-2+KS 2P+E 13A 250V~ 2M	66
VM80	PREPÁŤOVÁ OCHRANA MPE MINI 275V/50Hz	66
KOMUNIKÁCIE KM		
KM10--	ZÁSUVKA TV ZÁKLADNÁ 0dB 1M	68
KM20--	ZÁSUVKA TV ZÁKLADNÁ 0dB 2M	68
KM11--	ZÁSUVKA TV KONCOVÁ 1dB 1M	68
KM12--	ZÁSUVKA TV PRECHODNÁ 10dB 1M	68
KM15--	ZÁSUVKA SAT ZÁKLADNÁ 0dB 1M	69
KM24--	ZÁSUVKA SAT ZÁKLADNÁ 0dB 2M	69
KM16--	ZÁSUVKA SAT KONCOVÁ 1dB 1M	69
KM19--	ZÁSUVKA R ZÁKLADNÁ 0dB 1M	69
KM29--	ZÁSUVKA R ZÁKLADNÁ 0dB 2M	69
KM25--	ZÁSUVKA SAT-TV KONCOVÁ 1dB 2M	69
KM22--	ZÁSUVKA AUDIO 2xRCA 1M	70
KM23--	ZÁSUVKA AUDIO REPRODUKTOROVÁ 1M	70
KM30--	ZÁSUVKA TEL LT RJ11 6/4 1M	71
KM31--	ZÁSUVKA TEL BT SEC 6/6 1M	71
KM36--	ZÁSUVKA TEL KS RJ11 6/4 1M	71
KM37--	ZÁSUVKA CAT5e KS RJ45 8/8 1M	71
KM35--	ADAPTÉR KS 1M	71
KM38--	ADAPTÉR KS S OCHRANOU PROTI PRACHU 1M	71
KM50--	ADAPTÉR KS UNIVERZÁLNY 1M	72
KM40--	ADAPTÉR PD 1M	72
KM43--	ADAPTÉR PD S OCHRANOU PROTI PRACHU 1M	72
KM46--	ADAPTÉR R&M 1M	72
KM47--	ADAPTÉR R&M S OCHRANOU PROTI PRACHU 1M	72
KM45--	ADAPTÉR LK 1M	72
KA26	ADAPTÉR NEXSANS (N423.540N) 2M	73
KM48--	ADAPTÉR AT&T SYSTIMAX S OCHRANOU PROTI PRACHU 1M	73

kód	popis výrobku	strana
KOMUNIKAČNÉ PRÍSLUŠENSTVO KA		
KA10	KONEKTOR KS CAT3 RJ11 6/4	74
KA11	KONEKTOR KS CAT5e RJ45 8/8	74
KA12	KONEKTOR KS CAT5eS RJ45 8/8	74
KA15	KONEKTOR KS CAT6 SCHRACK RJ45 8/8	74
KA16	KONEKTOR KS CAT6S SCHRACK RJ45 8/8	74
KA17	KONEKTOR KS CAT6a SCHRACK RJ45 8/8	74
KA27	KONEKTOR KS HDMI	75
ELEKTRONIKA EM		
EM10--	STMIEVAČ ROTAČNÝ R 300W 1M	76
EM11--	STMIEVAČ ROT/STRIEDAVÝ RL 300W 1M	76
EM21	STMIEVAČ ZABUDOVATEĽNÝ RLC 300W	77
EM22	STMIEVAČ ZABUDOVATEĽNÝ R 500W	77
EM25--	STMIEVAČ UNIVERZÁLNY RLC 0-300W 2M	78
EM26--	KRYTKA NA SPÍNAČ OVLÁDACIA 2M	80
EM27	FILTER SIEŤOVÝCH PORÚCH	80
EM25PPOL20	SADA SPÍNAČ/STMIEVAČ UNIVERZÁLNY RLC 0 - 300 W 2M PP OL20	80
EM31--	IR SPÍNAČ 6A 250V~ 1M	81
EM35--	TERMOSTAT ZÁKLADNÝ 6A 230V~ 2M	82
EM40--	KARTOVÝ SPÍNAČ ZÁKLADNÝ 3A 250V~ 3M	83
EM41--	KARTOVÝ SPÍNAČ NA ŠETRENIE ELEKTRICKEJ ENERGIE ČIAROVÝ KÓD 3M	83
EM43--	KARTOVÝ SPÍNAČ RF HF 13,56MHz 12-24V 3M	83
EM47	KARTA ISO ČIAROVÝ KÓD	83
EM48	RELÉ JEDNOTKA NA KARTOVÝ SPÍNAČ 2x16A 250V~	84
EM60--	ZÁSUVKA NA HOLIACI STROJČEK 230V~/125V~ 3M	84
EM65--	NABÍJAČKA USB SV 1A 2M	84
EM55	LED NÚDZOVÉ SVIETIDLO 250V~ 1.5W, NiMH 6h 7M	85
EM50--	SVIETIDLO LED JEDNOFARBENÉ 250V~ 12W 2M	85
EM51--	SVIETIDLO LED DVOJFARBENÉ 250V~ 2x6W 2M	85
EM52--	LED LAMPA 3D DVOJFARBENÁ 230 V ~ 2x6W 2M	85
EM70--	SPÍNAČ NA ODLAČKY PRSTOV ARX ONE 2M	86
EM90--	BZUČIAK 8VA 220V~ 1M	87
EM91--	BZUČIAK 8VA 12V~ 1M	87
EM92--	ZVONEC 8VA 220V~ 1M	87
EM93--	ZVONEC 8VA 12V~ 1M	87
EM95--	REGULÁTOR HLASITOSTI PRE 100 V AUDIO VSTUP 35W 2M	88
EM96--	REGULÁTOR HLASITOSTI NIZKO-NAPĀŤOVÝ 4 - 8 Ω 35W 2M	88
SADY CM		
CM10--	SADA ZÁSUVIEK 2x SCHUKO 2P+E 16A 250V~ 4M	89
CM11--	SADA ZÁSUVIEK 3x SCHUKO 2P+E 16A 250V~ 7M	89
CM15	SADA UPÍNAČOV FARBENÁ 3x1,5mm ² 1M	90
CM16	SADA UPÍNAČOV FARBENÁ 3x2,5mm ² 2M	90
CM17	SADA SKRUTIEK 3,5x20	90
CM18	SADA SKRUTIEK 3,5x35	90
CM19	SADA SKRUTIEK 3,5x50	90
CM22--	SADA PRE SPÍNAČE IP44 2M	90
CM23	SADA PRE ZÁSUVKY IP44 2M	90
CM25--OL	SADA KÚPEĽNOVÁ 3x20AX 250V~ 4M OL	90
CM25--OS	SADA KÚPEĽNOVÁ 3x20AX 250V~ 4M OS	90
NM41	KÚPEĽNOVÝ MONTÁŽNY RÁMIK 4M	91
OL41--	RÁMIK LINE KÚPEĽNOVÁ SADA	91
OS41--	RÁMIK SOFT KÚPEĽNOVÁ SADA	91
ANTIBAKTERIÁLNY PROGRAM AW		
TM11AW	KRYTKA NA SPÍNAČ 1M	93
TM11AWIN	KRYTKA NA SPÍNAČ 1M INDIKÁTOR	93
TM12AW	KRYTKA NA SPÍNAČ 2M	93
TM11AWIN	KRYTKA NA SPÍNAČ 2M INDIKÁTOR	93
TM21AW	VÝPLŇ 1M	93
TM22AW	VÝPLŇ 2M	93
VM10AW	ZÁSUVKA SCHUKO+KS 2P+E 16A250V~ 2M	94
VM11AW	ZÁSUVKA SCHUKO+KS+KRYT 2P+E 16A 250V~ 2M	94
VM20AW	ZÁSUVKA EURO+KS 2P 10A 250V~ 1M	94
KM11AQ	ZÁSUVKA TV KONCOVÁ1dB1M	94
KM35AW	ADAPTÉR KS 1M	94
OS20AW	RÁMIK SOFT 2M	95
OS24AW	RÁMIK SOFT 2x2M	95
OS26AW	RÁMIK SOFT 3x2M	95
OS30AW	RÁMIK SOFT 3M	95
OS40AW	RÁMIK SOFT 4M	95
OS70AW	RÁMIK SOFT 7M	95
RÁMIKY PURE OP		
OP20--	RÁMIK PURE 2M	98
OP24--	RÁMIK PURE 2x2M	98
OP26--	RÁMIK PURE 3x2M	98
OP30--	RÁMIK PURE 3M	99
OP40--	RÁMIK PURE 4M	99
OP70--	RÁMIK PURE 7M	99
OP13--	RÁMIK PURE 1/3M	99
OP23--	RÁMIK PURE 2/3M	99

I N D E X

kód	popis výrobku	strana
RÁMIKY LINE OL		
OL20--	RÁMIK LINE 2M	102
OL24--	RÁMIK LINE 2x2M	102
OL26--	RÁMIK LINE 3x2M	102
OL28--	RÁMIK LINE 4x2M	102
OL30--	RÁMIK LINE 3M	103
OL40--	RÁMIK LINE 4M	103
OL70--	RÁMIK LINE 7M	103
OL10--	RÁMIK LINE 1M	103
OL13--	RÁMIK LINE 1/3M	103
OL23--	RÁMIK LINE 2/3M	103
RÁMIKY SOFT OS		
OS20--	RÁMIK SOFT 2M	106
OS24--	RÁMIK SOFT 2x2M	106
OS26--	RÁMIKSOFT 3x2M	106
OS28--	RÁMIK SOFT 4x2M	106
OS30--	RÁMIK SOFT 3M	107
OS40--	RÁMIK SOFT 4M	107
OS70--	RÁMIK SOFT 7M	107
OS10--	RÁMIK SOFT 1M	107
OS13--	RÁMIK SOFT 1/3M	107
OS23--	RÁMIK SOFT 2/3M	107
MONTÁŽNE RÁMIKY NM		
NM20	MONTÁŽNY RÁMIK SO SVORKAMI 2M	112
NM21	MONTÁŽNY RÁMIK BEZ SKRUTIEK 2M	112
NM24	MONTÁŽNY RÁMIK KOVOVÝ SO SVORKAMI 2M	112
NM25	MONTÁŽNY RÁMIK KOVOVÝ BEZ SKRUTIEK 2M	112
NM30	MONTÁŽNY RÁMIK SO SKRUTKAMI 3M	113
NM40	MONTÁŽNY RÁMIK SO SKRUTKAMI 4M	113
NM70	MONTÁŽNY RÁMIK SO SKRUTKAMI 7M	113
NM72	MONTÁŽNY RÁMIK SO SKRUTKAMI 2x7M	113
NM10	MONTÁŽNY RÁMIK SO SVORKAMI 1/2M	114
NM11	MONTÁŽNY RÁMIK BEZ SKRUTIEK 1/2M	114
NM23	MONTÁŽNY RÁMIK SO SVORKAMI 2/3M	114
NM32	MONTÁŽNY RÁMIK SO SKRUTKAMI 2/3M	114

Krabice

kód	popis výrobku	strana
OKRÚHLE KRABICE		
DE10	KRABICA OKRÚHLA PLYTKÁ DO STENY SM60-01	118
DE11	KRABICA OKRÚHLA HLBOKÁ DO STENY SM60-06	118
DE30	SPOJOVACÍ ČLÁNOK KRABICE DO STENY SM60-03	118
DE31	SPOJOVACÍ ČLÁNOK KRABICE DO STENY SM60-04	118
DE12	KRABICA OKRÚHLA DO STENY MD65-46	119
DE13	KRABICA OKRÚHLA DO STENY MD65-60	119
DE14	PREDĽŽENIE KRABICE DO STENY MD65-46	119
DE32	SPOJOVACÍ ČLÁNOK KRABICE DO STENY MD65-71	119
DE33	SPOJOVACÍ ČLÁNOK KRABICE DO STENY MD65-91	119
DE20	KRYT KRABICE OCHRANNÝ 60	119
DE21	KRYT KRABICE OCHRANNÝ 65	119
DE22	KRYT KRABICE DEKORATÍVNY SM60	119
HE10	KRABICA OKRÚHLA PRE DUTÉ STENY SM68x40	122
HE11	KRABICA OKRÚHLA PRE DUTÉ STENY SM68x55	122
BE10	KRABICA OKRÚHLA DO BETÓNU	122
BE11	KRABICA OKRÚHLA DO BETÓNU	122
BE20	MONTÁŽNY RÁMIK KRABICE DO BETÓNU	122
BE21	PRIECHODKA KRABICE DO BETÓNU 16	122
OBĎĽŽNIKOVÉ KRABICE		
DM30	KRABICA OBĎĽŽNIKOVÁ DO STENY PM3	126
DM31	KRABICA OBĎĽŽNIKOVÁ DO STENY PM3 65	126
DM40	KRABICA OBĎĽŽNIKOVÁ DO STENY PM4	126
DM41	KRABICA OBĎĽŽNIKOVÁ DO STENY PM4-65	126
DM70	KRABICA OBĎĽŽNIKOVÁ DO STENY PM7	127
DM71	KRABICA OBĎĽŽNIKOVÁ DO STENY PM7-65	127
DM72	KRABICA OBĎĽŽNIKOVÁ DO STENY PM72-65	127
DM80	SPOJOVACÍ ČLÁNOK NA KRABICE PM	127
DM33	KRYT KRABICE OCHRANNÝ PM3	128
DM34	KRYT KRABICE DEKORATÍVNY PM3	128
DM43	KRYT KRABICE OCHRANNÝ PM4	128
DM44	KRYT KRABICE DEKORATÍVNY PM4	128
DM73	KRYT KRABICE OCHRANNÝ PM7	128
DM74	KRYT KRABICE DEKORATÍVNY PM7	128
DM75	KRYT NA KRABICU DEKORATÍVNY PM72	129
HM30	KRABICA OBĎĽŽNIKOVÁ PRE DUTÉ STENY VM3	130
HM40	KRABICA OBĎĽŽNIKOVÁ PRE DUTÉ STENY VM4	130
HM70	KRABICA OBĎĽŽNIKOVÁ PRE DUTÉ STENY VM7	130
HM72	KRABICA OBĎĽŽNIKOVÁ DO DUTÝCH STIEN VM72	130
BM30	KRABICA OBĎĽŽNIKOVÁ PRE BETÓN BM3	131
BM40	KRABICA OBĎĽŽNIKOVÁ PRE BETÓN BM4	131
BM70	KRABICA OBĎĽŽNIKOVÁ PRE BETÓN BM7	131
BM80	FIXAČNÝ ČLÁNOK KRABÍC BM	131
BM82	DIŠTANČNÝ PROFIL PRE KRABICE BM	131

kód	popis výrobku	strana
ROZVODNÉ KRABICE		
DW10	ROZVODNÁ KRABICA OKRÚHLA DO STENY DSM78	134
HW10	ROZVODNÁ KRABICA OKRÚHLA PRE DUTÉ STENY SM78x45	134
DE23	KRYT KRABICE DEKORATÍVNY SM78	134
DE24	KRYT KRABICE OCHRANNÝ 78	134
HW20	ROZVODNÁ KRABICA ŠTVORCOVÁ DO STENY SM105x105	134
PRÍSLUŠENSTVO PRE ELEKTRICKÉ INŠTALÁCIE		
UW10--	SVORKOVNICA ZATVORENÁ PA 2x2,5mm ² 12P	136
UW11--	SVORKOVNICA JEDNORADOVÁ PA 2x4mm ² 12P	136
UW12--	SVORKOVNICA JEDNORADOVÁ PA 2x6mm ² 12P	136
UW15--	SVORKOVNICA JEDNORADOVÁ ZATVORENÁ PC 2x2,5mm ² 10P	136
UW16--	SVORKOVNICA JEDNORADOVÁ ZATVORENÁ PC 2x4mm ² 10P	136
UW17--	SVORKOVNICA JEDNORADOVÁ ZATVORENÁ PC 2x6mm ² 10P	136
UW20--	SVORKOVNICA DVOJRADOVÁ PA 1,5mm ² 12P	136
UW21--	SVORKOVNICA DVOJRADOVÁ PA 2,5mm ² 12P	136
UW22--	SVORKOVNICA DVOJRADOVÁ PA 4-6mm ² 12P	136
UW23--	SVORKOVNICA DVOJRADOVÁ PA 10mm ² 12P	136
UW40--	SVORKA BEZSKRUTKOVÁ PA 1,5mm ² 3P	137
UW41--	SVORKA BEZSKRUTKOVÁ PA 1,5mm ² 5P	137
UW42--	SVORKA BEZSKRUTKOVÁ PA 1,5mm ² 8P	137
UW45--	SVORKA BEZSKRUTKOVÁ PA 2,5mm ² 3P	137
UW46--	SVORKA BEZSKRUTKOVÁ PA 2,5mm ² 4P	137
UW47--	SVORKA BEZSKRUTKOVÁ PA 2,5mm ² 5P	137
UW50--	SVORKA BEZSKRUTKOVÁ PA 2,5mm ² 2/1P	137

Distribúcia

kód	popis výrobku	strana
RÁMY CUBO IP20 AC		
AC10--	RÁM NO CUBO IP20 1M	140
AC20--	RÁM NO CUBO IP20 2M	140
AC40--	RÁM NO CUBO IP20 4M	140
AC60--	RÁM NO CUBO IP20 6M	140
RÁMY CUBO IP55 AQ		
AQ20--	RÁMNO CUBO IP55 2M	141
AQ30--	RÁM NO CUBO IP55 3M	141
AQ31--	RÁM NO CUBO IP55 3M	141

INŠTALAČNÉ KANÁLY HLINÍKOVÉ

RT10	ADAPTÉR MA 92	142
RT12--	RÁMIK MA 92 2/3M	142
RT14--	RÁMIK MA 92 4M	142
RT17--	RÁMIK MA 92 7M	142
RT20--	ZÁKLAD KANÁLU MA 130x65	143
RT21--	ZÁKLAD KANÁLU MA 165x65	143
RT25--	KRYT KANÁLU MA 92	143
RT30	PRIEHRADKA MA 43	143
RT31	PRIEHRADKA AL. MA 43	143
RT32	PRIEHRADKA AL. MA DVOJITÁ 43	143
RT35--	KONCOVÝ PRVOK MA 130x65	144
RT36--	KONCOVÝ PRVOK MA 165x65	144
RT38	ROVNÝ SPOJOVACÍ PRVOK MA 65	144
RT40--	UNIVERZÁLNY ROH MA 130x65	144
RT41--	UNIVERZÁLNY ROH MA 165x65	144
RT42	UZEMŇOVACIA SVORKA MA 2x A6.3	144
RT43--	L KONCOVÝ PRVOK MA 130x65	145
RT44--	L KONCOVÝ PRVOK MA 165x65	145
RT45--	T PRVOK MA 130x65	145
RT46--	T PRVOK MA 165x65	145
RT50--	NOSNÍK STĽIPIKA MA 130x65	146
RT51--	NOSNÍK STĽIPIKA MA DVOJITÝ 130x65	146
RT52--	STĽIPIK MA 130x65x500	146
RT53--	STĽIPIK MA DVOJITÝ 130x65x500	146

PODLAHOVÉ KRABICE MT

RB30	PODLAHOVÁ KRABICA MT 7 H=53mm	148
RB40	PODLAHOVÁ KRABICA MT 7 H=88mm	148
RB31	PODLOŽKA PODLAHOVEJ KRABICE MT 7 H=53mm	148
RB41	PODLOŽKA PODLAHOVEJ KRABICE MT 7 H=88mm	148
RB33	PODLAHOVÁ KRABICA MT 14 H=53mm	148
RB43	PODLAHOVÁ KRABICA MT 14 H=88mm	148
RB34	PODLOŽKA PODLAHOVEJ KRABICE MT 14 H=53mm	149
RB44	PODLOŽKA PODLAHOVEJ KRABICE MT 14 H=88mm	149
RB36	PODLAHOVÁ KRABICA MT 21 H=53mm	149
RB46	PODLAHOVÁ KRABICA MT 21 H=88mm	149
RB37	PODLOŽKA PODLAHOVEJ KRABICE MT 21 H=53mm	149
RB47	PODLOŽKA PODLAHOVEJ KRABICE MT 21 H=88mm	149

ROZVODNÉ SKRINKY MO

RB10	ADAPTÉR PRE DIN LIŠTU 35mm 1M	150
RB11	ADAPTÉR PRE DIN LIŠTU 35mm 2M	150
RB20	ROZVODNÁ SKRINKA MO 12+2	151
RB21	ROZVODNÁ SKRINKA MO 24+4	151
RB22	ROZVODNÁ SKRINKA MO 36+6	151
RB23	ROZVODNÁ SKRINKA MO 48+8	151

ekonomik

kód	popis výrobku	pag.
SPÍNAČE SE		
SE10	SPÍNAČ JEDNOPÓLOVÝ 10AX 250V~	164
SE11	SPÍNAČ JEDNOPÓLOVÝ 10A 250V~	164
SE22	SPÍNAČ DVOJPÓLOVÝ 16AX 250V~	164
SE50	SPÍNAČ SÉRIOVÝ 10AX 250V~	164
SE51	SPÍNAČ SÉRIOVÝ 10A 250V~	165
SE52	SPÍNAČ ŽALÚZIOVÝ 10AX 250V~	165
SE53	SPÍNAČ ŽALÚZIOVÝ 10A 250V~	165
SE60	SPÍNAČ STRIEDAVÝ 10AX 250V~	165
SE63	SPÍNAČ DVOJITÝ STRIEDAVÝ 10AX 250V~	165
SE70	SPÍNAČ KRÍŽOVÝ 10AX 250V~	165
SE10--	SPÍNAČ JEDNOPÓLOVÝ 10AX 250V~	166
SE10--IN	SPÍNAČ JEDNOPÓLOVÝ 10AX 250V~ IN	166
SE11--	SPÍNAČ JEDNOPÓLOVÝ 10A 250V~	166
SE11--TI50	SPÍNAČ JEDNOPÓLOVÝ 10A 250V~ TI 50	166
SE11--TI51	SPÍNAČ JEDNOPÓLOVÝ 10A 250V~ TI 51	166
SE11--IL	SPÍNAČ JEDNOPÓLOVÝ 10A 250V~ IL	166
SE22--NT03	SPÍNAČ DVOJPÓLOVÝ 16AX 250V~ NT 03	166
SE50--	SPÍNAČ SÉRIOVÝ 10AX 250V~	167
SE51--	SPÍNAČ SÉRIOVÝ 10A 250V~	167
SE52--NT09	SPÍNAČ ŽALÚZIOVÝ 10AX 250V~ NT 09	167
SE53--NT09	SPÍNAČ ŽALÚZIOVÝ 10A 250V~ NT 09	167
SE60--	SPÍNAČ STRIEDAVÝ 10AX 250V~	167
SE63--	SPÍNAČ DVOJITÝ STRIEDAVÝ 10AX 250V~	167
SE70--	SPÍNAČ KRÍŽOVÝ 10AX 250V~	167
KRYTKY NA SPÍNAČ TE		
TE10--	KRYTKA NA SPÍNAČ OBYČAJNÁ	168
TE10--IN	KRYTKA NA SPÍNAČ IN	168
TE13--IL	KRYTKA NA SPÍNAČ S POPISNÝM ŠTÍTKOM IL	168
TE11--	KRYTKA NA SPÍNAČ SÉRIOVÁ	168
INDIKÁCIA IA		
IA10--	VÝBOJKA 230V~ 0,34W	169
IA20--	ŽIARIVKA LED 230V AC/DC 0,40W	169
IA21--	ŽIARIVKA LED 24V AC/DC 0,20W	169
IA22--	ŽIARIVKA LED 12V AC/DC 0,10W	169
ZÁSUVKY VE		
VE10--XO	ZÁSUVKA SCHUKO 2P+E 16A 250V~ XO	172
VE11--XO	ZÁSUVKA SCHUKO+KRYT 2P+E 16A 250V~ XO	172
VE12--XO	ZÁSUVKA SCHUKO 2P+E 16A 250V~ BV XO	172
VE13--XO	ZÁSUVKA SCHUKO+KRYT 2P+E 16A 250V~ BV XO	172
VE10--	ZÁSUVKA SCHUKO 2P+E 16A 250V~	172
VE11--	ZÁSUVKA SCHUKO+KRYT 2P+E 16A 250V~	172
VE12--	ZÁSUVKA SCHUKO 2P+E 16A 250V~ BV	172
VE13--	ZÁSUVKA SCHUKO+KRYT 2P+E 16A 250V~ BV	172
VE40--XO	ZÁSUVKA FRANCÚZSKA 2P+E 16A 250V~ XO	173
VE41--XO	ZÁSUVKA FRANCÚZSKA+KRYT 2P+E 16A 250V~ XO	173
VE42--XO	ZÁSUVKA FRANCÚZSKA 2P+E 16A 250V~ BV XO	173
VE43--XO Z	ZÁSUVKA FRANCÚZSKA+KRYT 2P+E 16A 250V~ BV XO	173
VE40--	ZÁSUVKA FRANCÚZSKA 2P+E 16A 250V~	173
VE41--	ZÁSUVKA FRANCÚZSKA+KRYT 2P+E 16A 250V~	173
VE42--	ZÁSUVKA FRANCÚZSKA 2P+E 16A 250V~ BV	173
VE43--	ZÁSUVKA FRANCÚZSKA+KRYT 2P+E 16A 250V~ BV	174
VE16--	ZÁSUVKA SCHUKO DVOJITÁ 2P+E 16A 250V~ BV	174
VE45--	ZÁSUVKA FRANCÚZSKA DVOJITÁ 2P+E 16A 250V~	174
VE30--	ZÁSUVKA 2P 16A 250V~ 132	
KOMUNIKÁCIE KE		
KE11	ZÁSUVKA TV-R KONCOVÁ 2dB	175
KE12	ZÁSUVKA TV-R PRECHODNÁ 8,5dB	175
KE16	ZÁSUVKA SAT-TV-R KONCOVÁ 3dB	175
KE36	ZÁSUVKA TEL KS RJ11 6/4	175
KE37	ZÁSUVKA CAT5e KS RJ45 8/8	176
KE38	ZÁSUVKA TEL KS DVOJITÁ 2x RJ11 6/4	176
KE39	ZÁSUVKA CAT5e KS DVOJITÁ 2x RJ45 8/8	176
KE45	ADAPTÉR KS	176
KE46	ADAPTÉR KS DVOJITÝ	176
KE47	ADAPTÉR PD DVOJITÝ	176
KE10--	ZÁSUVKA TV ZÁKLADNÁ 0dB	177
KE11--	ZÁSUVKA TV-R KONCOVÁ 2dB	177
KE12--	ZÁSUVKA TV-R PRECHODNÁ 8,5dB	177
KE16--	ZÁSUVKA SAT-TV-R KONCOVÁ 3dB	177
KE22--	ZÁSUVKA AUDIO 2xRCA	177
KE23--	ZÁSUVKA AUDIO REPRODUKTOROVÁ	177
KE36--	ZÁSUVKA TEL KS RJ11 6/4	178
KE37--	ZÁSUVKA CAT5e KS RJ45 8/8	178
KE38--	ZÁSUVKA TEL KS DVOJITÁ 2xRJ11 6/4	178
KE39--	ZÁSUVKA CAT5e KS DVOJITÁ 2xRJ45 8/8	178
KE35--	ZÁSUVKA TEL LT RJ116/4	178
KRYTY PA		
PE10--	KRYT TV-R 2P/3P	179
PE20--	KRYT KS SAMOSTATNÝ	179
PE21--	KRYT KS DVOJITÝ	179
PE30--	KRYT TAE/TDO	179

kód	popis výrobku	pag.
ELEKTRONIKA EE		
EE15	STMIEVAČ ROTAČNÝ STR RL 400W	180
EE16	STMIEVAČ ROTAČNÝ STR RLC 400W	180
EE17	STMIEVAČ ROTAČNÝ FAN 600VA	181
EE15--	STMIEVAČ ROTAČNÝ STR RL 400W	181
EE16--	STMIEVAČ ROTAČNÝ STR RLC 400W	181
KRYTY ELEKTRONIKY PE		
PE40--	KRYT STMIEVACÍ SPÍNAČ Ø4	183
PE41--	KRYT STMIEVACÍ SPÍNAČ Ø6	183
PRÍSLUŠENSTVO AE		
AE10--	VÝPLŇ	184
AE20--	PRÍPOJKA PÄTPÓLOVÁ FIXNÁ 3P+N+E 5x4mm ²	184
AE30--	RÁM NO 1	184
AE50--	STENOVÝ CHRÁNIČ	185
AE51--	DETSKÁ OCHRANA ZÁSUVKY	185
RÁMIKY OE		
OE10--	RÁMIK EKONOMIK 1	186
OE20--	RÁMIK EKONOMIK 2 HORIZONTÁLNY	186
OE21--	RÁMIK EKONOMIK 2 VERTIKÁLNY	186
OE30--	RÁMIK EKONOMIK 3 HORIZONTÁLNY	186
OE31--	RÁMIK EKONOMIK 3 VERTIKÁLNY	187
OE40--	RÁMIK EKONOMIK 4 HORIZONTÁLNY	187
OE41--	RÁMIK EKONOMIK 4 VERTIKÁLNY	187
OE90--	RÁMIK EKONOMIK DEKORATÍVNY	187

fontana

kód	popis výrobku	strana
SPÍNAČE SF		
SF10--	SPÍNAČ JEDNOPÓLOVÝ IP44 10AX 250V~	190
SF10--TI	SPÍNAČ JEDNOPÓLOVÝ IP44 10AX 250V~ TI	190
SF11--TI	KRYTKA NA TLACIDLO JEDNOPÓLOVÁ IP44 10A 250V~ TI	190
SF20--	SPÍNAČ DVOJPÓLOVÝ IP44 10AX 250V~	190
SF50--	SPÍNAČ SÉRIOVÝ IP44 10AX 250V~	191
SF51--	SPÍNAČ SÉRIOVÝ IP44 10A 250V~	191
SF60--	SPÍNAČ STRIEDAVÝ IP44 10AX 250V~	191
SF60--TI	SPÍNAČ STRIEDAVÝ IP44 10AX 250V~ TI	191
SF63--	SPÍNAČ DVOJITÝ STRIEDAVÝ IP44 10AX 250V~	191
SF70--	SPÍNAČ KRÍŽOVÝ IP44 10AX 250V~	191
ZÁSUVKY VF		
VF10--	ZÁSUVKA SCHUKO+KRYT IP44 2P+E 16A 250V~	192
VF12--	ZÁSUVKA SCHUKO+KRYT IP44 2P+E 16A 250V~ BV	192
SADY CF		
CF10--	SADA ZÁSUVKA SCHUKO DVOJITÁ HORIZ IP44 2x2P+E 16A 250V~	193
CF11--	SADA ZÁSUVKA SCHUKO DVOJITÁ VERT IP44 2x2P+E 16A 250V~	193
CF12--	SADA ZÁSUVKA SCH+SPÍNAČ STR HORIZ IP44 10AX 250V~	193
CF13--	SADA ZÁSUVKA SCH+SPÍNAČ STR VERT IP44 10AX 250V~	194
CF14--	SADA ZÁSUVKA SCHUKO DVOJITÁ HORIZ IP44 2x2P+E 16A 250V~ BV	194
CF15--	SADA ZÁSUVKA SCHUKO DVOJITÁ VERT IP44 2x2P+E 16A 250V~ BV	194
CF16--	SADA ZÁSUVKA SCH+SPÍNAČ STR HORIZ IP44 10AX 250V~ BV	194
CF17--	SADA ZÁSUVKA SCH+SPÍNAČ STR VERT IP44 10AX 250V~ BV	194
PRÍSLUŠENSTVO AF		
AF10--	ROZVODNÁ KRABICA IP44 RN01	195
AF20--	ROZVODNÁ KRABICA IP55 ND01	195





MODUL

— funkčné moduly
function elements



54

dizajn
design

PURE
line
soft



96

krabice
boxes



118

distribúcia
distribution



140

ekonomik —



164

fontana —



190





TEM

TEM ČATEŽ d.d.
Čatež 13, 8212 VELIKA LOKA
SLOVENIJA
tem@tem.si
www.tem.si
T +386(0)7 348 99 00
F +386(0)7 348 99 99

www.tem.si

SK₂₀₁₄